

CONSTRUCTION PERMIT ISSUED BY  
Utah Department of Environmental Quality  
Utah Division of Water Quality

Date: 03/18/2021

Review Engineer:   
WC

Director:   
EG

# APPENDIX A DRAWINGS & SPECIFICATIONS

## Appendix C Brine Pond Engineering Plans and Specifications

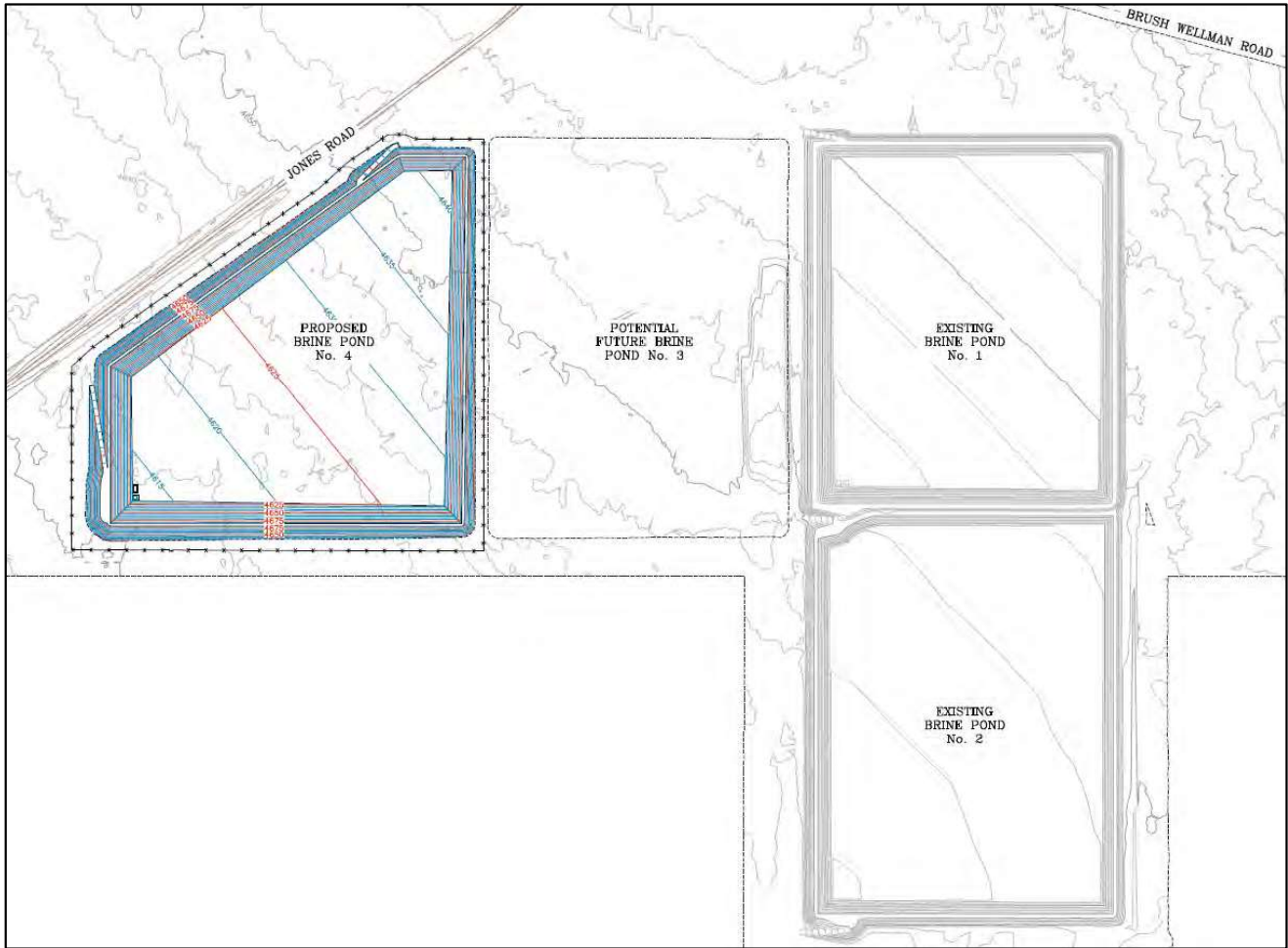

## MAGNUM SOLUTION MINING, LLC - BRINE POND 4 FINAL DESIGN REPORT – REVISION 1

Prepared for:  
**Magnum Solution Mining, LLC**  
 3165 East Millrock Drive, Suite 330  
 Holladay, Utah 84121

Prepared by:  
**NewFields Mining Design & Technical Services**  
 9400 Station Street, Suite 300  
 Lone Tree, Colorado 80124



NewFields Job No. 475.0093.020  
Date – January 29, 2020







## TABLE OF CONTENTS

1.	INTRODUCTION.....	1
1.1.	Project Background .....	1
1.2.	Project Description .....	1
1.3.	Project Location.....	2
1.4.	Site Conditions.....	2
1.5.	Scope of Work .....	2
1.6.	Use of this Report.....	3
2.	GEOTECHNICAL INVESTIGATION .....	3
3.	GEOLOGIC AND GEOTECHNICAL CONDITIONS.....	3
3.1.	Geologic Setting.....	3
3.2.	Surface Conditions.....	4
3.3.	Subsurface Conditions .....	4
3.4.	Seismic Hazard.....	5
3.4.1.	Design Ground Motions .....	5
4.	BRINE POND 4 DESIGN .....	6
4.1.	Brine Pond 4 Configuration.....	6
4.2.	Site Grading .....	6
4.3.	Embankment Crest .....	7
4.4.	Liner System .....	7
4.5.	Leak Collection and Recovery System (LCRS).....	7
4.6.	Process Component Monitoring System (PCMS) .....	8
4.7.	Diversion Channel.....	9
4.8.	Groundwater Monitoring .....	9
4.9.	Brine Recovery.....	9
4.10.	Brine Influent Pipeline .....	10
5.	GEOTECHNICAL EVALUATION .....	10
5.1.	Liquefaction Evaluation .....	10
5.2.	Brine Pond 4 Stability Evaluation .....	10
5.2.1.	Stability Model Development.....	11
5.2.2.	Material Properties .....	11
5.2.3.	Results of the Stability Evaluation .....	12
5.3.	Deformation Analysis.....	12
5.4.	Settlement Evaluation .....	13
6.	CONSTRUCTION QUALITY CONTROL AND CONSTRUCTION QUALITY ASSURANCE (CQC/CQA) PLAN .....	13
7.	REFERENCES.....	14



### LIST OF TABLES USED IN THIS REPORT

- TABLE 1 SEISMIC HAZARD PARAMETERS
- TABLE 2 MATERIAL PROPERTIES USED IN THE STABILITY ANALYSES
- TABLE 3 SUMMARY OF CALCULATED MINIMUM FACTORS OF SAFETY

### LIST OF APPENDED FIGURES

- FIGURE 1 GEOTECHNICAL SECTIONS PLAN VIEW
- FIGURE 2 GEOTECHNICAL SECTION A
- FIGURE 3 GEOTECHNICAL SECTION B
- FIGURE 4 BRINE POND 4 FILLING CURVE

### LIST OF APPENDED TABLES

- TABLE 1 BOREHOLE LAB TESTING SUMMARY
- TABLE 2 TEST PIT LAB TESTING SUMMARY
- TABLE 3 BRINE POND 4 FILLING TABLE

### LIST OF APPENDICES

- APPENDIX A DESIGN CRITERIA
- APPENDIX B TECHNICAL SPECIFICATIONS
  - APPENDIX B1 EARTHWORKS
  - APPENDIX B2 CPEP
  - APPENDIX B3 HDPE PIPE
  - APPENDIX B4 GEOMEMBRANE
  - APPENDIX B5 GEOTEXTILE
  - APPENDIX B6 GEONET
- APPENDIX C DESIGN CALCULATIONS
  - APPENDIX C1 LCRS and PCMS Leakage Rates
  - APPENDIX C2 Liner Pull-Out Calculation
  - APPENDIX C3 LCRS and PCMS Sump Sizing
  - APPENDIX C4 Wave Run Up Analysis for Freeboard



- APPENDIX D BOREHOLE LOGS
- APPENDIX E LABORATORY RESULTS
- APPENDIX F GEOTECHNICAL EVALUATION
  - APPENDIX F1 POST SEISMIC STABILITY RESULTS
  - APPENDIX F2 DEFORMATION ANALYSIS RESULTS
  - APPENDIX F3 LIQUEFACTION ANALYSIS RESULTS
- APPENDIX G CONSTRUCTION QUALITY CONTROL/CONSTRUCTION QUALITY ASSURANCE (CQC/CQA) PLAN – PREPARED BY HANSEN, ALLEN & LUCE, INC., 2013
- APPENDIX H EXCERPT FROM GEOTECHNICAL INVESTIGATION FOR EVAPORATION POND SITE – PREPARED BY IGES, 2010
- APPENDIX I NEWFIELDS 2016 GEOTECHNICAL INVESTIGATION FINDINGS

#### **ATTACHMENTS**

- ATTACHMENT 1 BRINE POND 1, DETERMINISTIC SEISMIC HAZARD ASSESSMENT (AMEC 2011)
- ATTACHMENT 2 SEED MIX DESIGN



## LIST OF DRAWINGS

- A000 COVER SHEET & DRAWING INDEX
- A010 GENERAL ARRANGEMENT
- A020 STAGE-STORAGE CURVES AND POND PROPERTIES
- A050 GEOTECHNICAL INVESTIGATION LOCATIONS
- A100 OVERALL GRADING PLAN
- A105 OVERALL GRADING ISOPACH
- A110 TYPICAL EMBANKMENT SECTIONS AND DETAILS SHEET 1 OF 2
- A115 TYPICAL EMBANKMENT SECTIONS AND DETAILS SHEET 2 OF 2
- A120 POND 4 NORTHEAST ACCESS RAMP PLAN AND PROFILE
- A135 POND 4 SOUTHWEST ACCESS RAMP PLAN AND PROFILE
- A140 BRINE RECOVERY SYSTEM SECTION AND DETAILS
- A150 POND INLET PLAN
- A160 POND INLET SECTIONS AND DETAILS
- A200 POND BASIN PIPING PLAN
- A205 POND BASIN PIPING SECTIONS AND DETAILS
- A220 LEAK COLLECTION AND RECOVERY SYSTEM DETAILS
- A230 PROCESS COLLECTION AND MONITORING SYSTEM PLAN
- A300 POND SITE GROUNDWATER DEPTHS PLAN AND PROFILE
- A400 STORMWATER DIVERSION AND SETTLEMENT MONUMENT PLAN
- A500 BRINE RECOVERY MANIFOLD SECTIONS AND DETAILS
- A600 WILDLIFE FENCE DETAILS



## 1. INTRODUCTION

NewFields Mining Design and Technical Services (NewFields) was commissioned by Magnum Solution Mining, LLC (Magnum) to provide engineering services for the final design of Brine Pond 4. Pond 4 has been designed to the same standards as the existing Sawtooth Brine Ponds 1 and 2 with some improvements made which are illustrated on the drawings and identified in this document. Two geotechnical investigations (one performing test pits and the other geotechnical borings), as well as a groundwater depth confirmation investigation, were completed in the pond footprint, and the findings are presented herein.

### 1.1. Project Background

Magnum is developing a series of energy storage projects that involve the construction of solution mined storage caverns in a subsurface salt deposit. The resulting brine solution from the mining process will be stored in double geomembrane lined engineered brine ponds such as Brine Pond 4.

The design for three Ponds was originally completed by AMEC (2011), and included a series of 3 evaporation ponds in a west to east alignment. After receipt of a Utah Division of Water Rights (DWRi) Dam Impoundment Permit and Division of Water Quality Groundwater Discharge Permit, Magnum constructed Pond 1 in 2013 with the original permitted design completed by AMEC (2011). The first pond is referred to as Sawtooth Brine Pond 1.

NewFields completed the design for another pond in 2015, which is located directly south of Sawtooth Brine Pond 1 and is referred to as Sawtooth Brine Pond 2. That pond was constructed before the end of 2015.

NewFields completed the design for Brine Pond 3 and a slightly different configuration of Brine Pond 4 in 2017, with Pond 3 west of and sharing an embankment with Pond 1, and Pond 4 west of and sharing an embankment with Pond 3. Magnum requested a revised Brine Pond 4 be designed in early 2020, which is the focus of this report.

### 1.2. Project Description

The goal of this design for the Brine Pond 4, provided by NewFields within this report, is intended to obtain a DWRi Dam Impoundment Permit and Division of Water Quality Groundwater Discharge Permit.

The proposed Pond 4 is located to the west of Sawtooth Brine Pond 1 near Jones Road. Pond 4 has an approximate footprint of 168 acres (the footprint of the outside toe). The vacant space to remain between ponds 1 and 4 is slightly larger than the pond 3 size and shape designed by NewFields in 2017.



### 1.3. Project Location

The project is located approximately 10 miles north of Delta in Millard County, Utah and includes leased lands from the Utah School and Institutional Trust Lands Administration (SITLA). A county and vicinity map is shown on Drawing A000.

### 1.4. Site Conditions

Site conditions are similar to those described for the design of Ponds 1 and 2 (AMEC, 2011; NewFields, 2015). A geotechnical investigation consisting of test pits was completed in 2016 (provided in Appendix I), and boreholes were drilled within the footprint of the proposed embankments in 2017 (provided in Appendix D). In June 2020 four pits were dug near the proposed southwest corner of pond 4 to confirm that estimated depth to groundwater had not significantly changed since the geotechnical investigations were completed. Surface and subsurface conditions encountered are discussed in detail in Section 2 and 3.

### 1.5. Scope of Work

Per the proposal submitted to Magnum on March 23, 2020 (NewFields Proposal No. 20PD.0036 Rev.1) the scope of work included the following:

- Complete a groundwater depth investigation near the proposed pond 4 sumps to see if depth to groundwater has changed since the previous geotechnical investigations were completed more than 3 years prior.
- Provide engineering design and permitting support for Brine Pond 4 including:
  - Review and revise existing design criteria developed during the previous phase,
  - Develop a grading plan for Brine Pond 4 utilizing AutoCAD Civil3D. The plan will utilize locally available material and will balance cut and fills to the greatest extent possible. The groundwater level in the sump area of the ponds will be a limiting factor for the grading plans and will be considered as the design is developed and advanced,
  - Prepare geomembrane plans and details for installation,
  - Prepare Leak Collection and Recovery System (LCRS) and Process Component Monitoring System (PCMS) plans and details as well as recommend pumping systems,
  - Final Design report and design drawings to be stamped by the Engineer of Record (EOR),
  - Review and utilize the existing technical specifications for earthworks, geosynthetic materials, concrete, and pipework.





## **1.6. Use of this Report**

This report has been prepared exclusively for Magnum. No third party, other than the design team (NewFields), shall be entitled to rely on any information, conclusions, opinions, or other information contained herein without the express written consent of Magnum.

## **2. GEOTECHNICAL INVESTIGATION**

The previous geotechnical investigations performed by NewFields consisted of test pits, whose locations are presented in Figure 1 included in Appendix I and the findings described in the Future Brine Pond Expansion Technical Memorandum (NewFields, 2017) presented in Appendix I. The boreholes were done in 2017 and are provided in Appendix D and the location of them is shown on drawing A050.

The revised proposed location of Pond 4 is within the area where the previous geotechnical investigations were performed, therefore a new investigation was not required or completed for this design. However, NewFields performed an investigation to confirm that groundwater depths have not significantly changed in the previous 3 years. In June 2020, four excavations were dug near the proposed Brine Pond 4 southwest embankment corner. The groundwater measured in all four locations was found at the expected depth and confirmed that groundwater depths have not changed.

## **3. GEOLOGIC AND GEOTECHNICAL CONDITIONS**

### **3.1. Geologic Setting**

The project site is located within the Sevier Desert in east-central Millard County, Utah. The Sevier Desert basin is within the eastern margin of the Basin and Range Physiographic Province. Beginning 20 to 7 million years before present (Ma), the basin opened up dominantly by crustal extension through normal faulting within the region rather than graben subsidence (Oviatt, 1989). The basin is bounded on the east by the Canyon Range and the Gilson Mountains, on the north by the Sheeprock Mountains, Simpson Mountains, and Keg Mountain, and on the west by the Drum Mountains, Little Drum Mountains, and the House Range. The southern margin is less defined before transitioning into the Black Rock Desert.

The basin was a freshwater lake during the early Pleistocene, as indicated by the presence of calcareous clays and silts. During the Middle Pleistocene, the basin experienced a time of erosion and sediment degradation by receding lake waves lifting sediments into suspension where they were transported away in fluvial systems (Oviatt, 1989). Wind degradation also occurred during this time as the lake(s) shorelines receded. A shallow, freshwater lake filled the basin again prior to the transgression of Lake Bonneville around 20 to 21 thousand years ago. As Lake Bonneville began to regress into the Great Salt Lake basin, another freshwater lake



formed in the basin. This lake was present long enough to develop a prominent 10-mile long shoreline northeast of Sevier Lake. This was Lake Gunnison, which overflowed north into the Great Salt Lake Desert via the Old River Bed channel. After Lake Gunnison retreated, the Sevier and Beaver Rivers deposited low gradient alluvial fans comprised of fine-grained sediments.

Surficial sediments in the area consist of fine-grained lacustrine deposits of Lake Bonneville and of pre-Bonneville lakes, vast areas of fine-grained alluvium deposited by the Sevier and Beaver Rivers, and coarser-grained deposits in piedmont areas. Thin aeolian deposits are also found throughout the area.

Regional structure near the project site was discussed by IGES (2009) and consists of two northeast trending normal faults.

### **3.2. Surface Conditions**

The surface of the proposed Pond 4 is moderately vegetated with small shrubs and grasses. It is generally flat to undulating with an overall slope to the southwest. There are occasional dunes with their axis generally northeast to southwest, perpendicular to the prevailing wind direction from the northwest, in the middle of the proposed pond. These dunes, and the surface sediments to the east, are aeolian sediments that were likely deposited after the historic lakes drained.

### **3.3. Subsurface Conditions**

The subsurface soils beneath the proposed Pond 4 to a depth of approximately 75 ft bgs are generally interbedded fluvial and lacustrine deposits with significant crossbedding sedimentary structure in the fluvial deposits. The predominant soil type is poorly-graded sand to silty sand with thin to thick sequences of lacustrine clays sporadically located through the subsurface.

Two cross sections were generated along the proposed interior toe of the proposed Pond 4 embankments, as shown on Appended Figure 1. These sections extend to the east into the footprints of Sawtooth Brine Pond 1 to illustrate the similar depositional environments of complexly interbedded fluvial deposits with lacustrine sediments within the subsurface conditions of the two facilities. The northern and southern cross sections are shown on Figures 2 and 3, respectively.

In general, the existing groundwater table is approximately 20 to 30 ft bgs throughout the footprint of the proposed Pond 4. Observations from geotechnical borings indicates the direction of groundwater flow is to the southwest.

SPT blowcounts from field penetration tests are commonly used to estimate engineering parameters of soil deposits such as relative density or stiffness, strength, and compressibility.



Based on blowcounts, the cohesionless sediments tend to be medium dense to very dense and the cohesive sediments tend to be stiff to hard. Strength properties of the foundation materials for the geotechnical evaluation of the facility were also estimated from blowcounts.

### 3.4. Seismic Hazard

A probabilistic seismic hazard evaluation was previously performed for the facility (AMEC, 2011) based on Utah Administrative Code (UAC) R655-11-5A and is included as Attachment 1. The MCE is based on the probabilistic seismic hazard assessment considering a 4,975-year return event, and the associated PGA for this event is 0.39g based on a moment magnitude event of 6.2 at a distance of 14.7km.

A deterministic seismic hazard assessment (DSHA) was previously performed for the design of brine pond 1 (AMEC, 2011) and is included as Attachment 1. The DSHA reports both mean and mean plus one standard deviation ground motion parameters. According to Utah Administrative Code (UAC R655-11-5A), “low hazard dams will be evaluated using ground motion parameters that are at least equal to mean (50<sup>th</sup>) predictions.” It is our assessment that the facility should be classified as low hazard per Utah Title 73.

#### 3.4.1. Design Ground Motions

NewFields has reviewed the DSHA, agrees with the selection of the design seismic event, and believes they are still valid for the current understanding of regional seismicity. The ground motion parameters for the deterministic and probabilistic seismic hazards are listed in the following tables. Based on the listed PGAs, the design acceleration utilized in the geotechnical evaluation of Pond 4 is 0.38g.

**TABLE 1 – SEISMIC HAZARD PARAMETERS**

DETERMINISTIC SEISMIC HAZARD ASSESSMENT			
Seismic Source	Magnitude (M <sub>w</sub> )	Dist. to Site (km)	PGA, Soil Site (g)
Sugarville FZ	5.8	1.8	0.25
Wasatch FZ (Levan Section)	6.7	56.4	0.05
Wasatch FZ (full rupture)	8.2	56.4	0.12
PROBABALISTIC SEISMIC HAZARD ASSESSMENT			
4,975-Year Return Event	6.2	14.7	0.38

The Sugarville Fault Zone, the closest fault to the site has a calculated MCE of 5.8 and a mean peak ground acceleration (PGA) of 0.25g. However, based on the inactive, small-scale nature of the Sugarville Fault Zone, it is very unlikely an MCE would be generated from this fault zone. A more realistic scenario may be an MCE generated by the most tectonically active USGS seismic



hazard classified fault zone in proximity to site. An 8.2 magnitude MCE along the Wasatch Fault Zone would result in a mean PGA of 0.12g. This event is recommended for post closure design (AMEC, 2011). However, a probabilistic PGA of 0.38g was used for the design and greatly exceeds values generated from the deterministic assessment.

## **4. BRINE POND 4 DESIGN**

### **4.1. Brine Pond 4 Configuration**

Brine Pond 4 was designed very similarly to the Sawtooth Brine Ponds 1 & 2. Containment will be provided by embankments constructed with homogenous fill material excavated from the pond areas. The embankments will have a crest width of 22 ft, 2.5H:1V interior slopes, and 2H:1V exterior slopes. See Drawings A110 and A115 for embankment sections and details.

The Pond 4 depth varies from 40 to 68 ft and the maximum embankment height is approximately 58 ft that correlates to a crest elevation of 4683 ft above mean sea level (amsl). To contain the required operational volume and provide sufficient storage for the 100 year/24 hour storm event, the resulting maximum Pond 4 elevation is 4680 ft. Given these elevations, the resultant freeboard to the embankment crest is 3 ft.

The embankments may settle over the life of the facility to a total of 1 foot (see Section 5.4) and as such the 3 ft design freeboard will require lowering the maximum operating water elevations accordingly if settlement occurs. However, the observed settlement of Brine Pond 1 has been very minimal (~1-inch) and therefore this 1-foot settlement estimate may be quite conservative. To verify that a 3 ft design freeboard is sufficient, a wave height calculation was completed. The maximum potential total wave run up was calculated to be 2.8 feet and therefore the 3 ft of freeboard is sufficient. See Appendix C4 for calculation details.

Note that the operational volume was given by Magnum and the meteoric volume for the 100 year/24 hour storm event, which results in a storm depth of 2 inches (in), was determined from the original design. See Appended Figure 4 and Appended Table 3 for the Brine Pond 4 filling curve and table.

These design elements in addition to the design features discussed in the following sections are presented in the Design Criteria in Appendix A. See Drawing A020 and A100 for details regarding the Brine Pond 4 layout and configuration.

### **4.2. Site Grading**

The disturbance area of Brine Pond 4 is approximately 168 acres (the footprint of the outside toe). The area will be cleared of deleterious material and detritus (assumed depth of 3-inches) and the earthwork construction will include excavation of borrow material from the pond



bottom and placement of the material as a continuous embankment around the perimeter of the pond. The basin grading will generally conform to the existing natural grade and will slope at an approximate 0.80 percent grade from the northeast corner to the southwest corner, where the LCRS and PCMS sumps will be located. Full descriptions of these systems are presented in Sections 4.5 and 4.6 of this report.

The interior surfaces of the pond will be constructed with a prepared subgrade that will be constructed and compacted in accordance with the Technical Specification presented in Appendix B.

#### **4.3. Embankment Crest**

As stated previously the embankment crest width is 22 ft and provides for a 10.5 ft wide access road and 1.5 ft tall safety berms. The access road will be overlain by a 6-in thick layer of wearing course. Where the access road crosses the brine delivery pipe a 1 ft minimum ramp will be constructed. Refer to Drawings A110, A115, A120 and A135 for embankment crest and pipe ramp details.

#### **4.4. Liner System**

Brine Pond 4 will have a composite liner system that includes both an LCRS and PCMS. The system design consists of a primary liner of 80-mil HDPE single-sided textured geomembrane and a secondary 60-mil HDPE geomembrane liner. The liners will be separated by a drainage layer using either 130-mil drainage studs fabricated with the secondary liner and installed face up against the primary liner, or 250-mil geonet. The double liner system will cover the pond basin and interior embankment slopes. Installation requirements are presented in the Technical Specifications in Appendix B.

The liner anchor trench will be constructed at a setback of 3 ft with trenched dimensions of 4 ft deep by 3 ft wide. To further secure the anchor trench on the embankment crest, 6 inches of the total trench backfill will be compacted on the secondary liner prior to placement of the primary liner. The factor of safety for tensile failure and anchor pull-out due to self-weight was analyzed and the configuration was deemed suitable. See Appendix C2 for calculations.

#### **4.5. Leak Collection and Recovery System (LCRS)**

The LCRS utilizes the interstitial space created by the drainage layer to transmit potential flows between the primary and secondary liners. In the event that a leak occurs in the primary liner, the fluid will drain along the secondary liner to the LCRS sump, which is located in the pond's low point in the southwest corner of the pond. Approximately six 18-in wide strip drains will be installed in a radial pattern originating at the sump in the southwestern corner of the pond and upgradient to intersect all geomembrane panels on the floor of the pond. The addition of the



strip drains will help facilitate flow to the LCRS sump. In addition to the transmission of flows between the liners through the strip drains and leak detection layer, a 4-in diameter perforated HDPE collection pipe will be placed along the inner embankment toes to increase flows to the sump.

Any potential leaks will be detected through the use of submersible pumps placed in the leak detection sump. The pumps will be encased in two 18-in diameter HDPE DR11 pump sleeves that will be installed between the primary and secondary liners. The pumps shall be automated to turn on at regular intervals such that the water in the sump is maintained a minimum. The discharged fluid will be circulated back to the pond.

The LCRS sump has 50 by 25 ft base dimensions, is 3.5 ft deep from the pond bottom and has 2.5H:1V side slopes. For sump sizing see Appendix C3.

The sump will be lined with 60-mil HDPE geomembrane that runs continuous from the pond basin lining and be overlain by a 10-oz non-woven cushion geotextile. Select gravel will be placed in the sump to a depth of 3.5 ft which is surrounded with a perforated sacrificial liner with perforations to prevent gravel dimpling on the primary and secondary liners, and overlain by 10-oz non-woven geotextile and primary liner which runs continuous from the pond basin lining. Two (2) – 18 in diameter DR 11 pipe pump sleeves will be installed from the sump bottom to the pond crest to be used as a riser pipe. See Drawing A220 for further details and the Technical Specifications in Appendix B for construction details.

Leakage flow rates were calculated based on principles from Giroud et al. (1997) using a formula for the “Geomembrane Leakage Rate Underlain by Permeable Media.” Given the average head on the liner and the total wetted area of Brine Pond 4 (the maximum operating level) the leakage rate was calculated to be 460 gallons per minute (gpm) for Brine Pond 4. For further details, see the leakage rate calculation presented in Appendix C1.

#### **4.6. Process Component Monitoring System (PCMS)**

A PCMS will be installed, consistent with Ponds 1 and 2, to detect potential leaks in the secondary liner. The PCMS consists of toe drains along the length of the embankment that is made up of 4 in diameter perforated CPe pipes placed in 0.5 ft deep trenches located beneath the secondary liner. Additionally, three (3) trenches will be excavated along the pond bottom, orthogonal to the pond basin grading. The pipes will transmit flows to the PCMS sumps located in the low point in the southwest portion of the pond.

The PCMS sump was sized consistent with the PCMS dimensions of Brine Ponds 1 and 2. For sump sizing see Appendix C3.





The PCMS has 25 by 25 ft base dimensions and 2.5H:1V side slopes. An 80-mil HDPE single-sided textured geomembrane will be placed on the sump bottom to prevent vertical infiltration of water. Overlaying the geomembrane will be a 10-oz non-woven geotextile followed by 2 ft of select gravel and the double liner system which runs continuous from pond basin lining. A sacrificial liner with perforations will surround the gravel to prevent dimpling of the double liner. Two (2) – 18 in diameter DR 11 pipe pump sleeves will be installed from the sump bottom to the pond crest to be used as a riser pipe. See Drawing A230 for further details and the Technical Specifications in Appendix B for construction details.

Leakage flow rates were calculated based on principles from Giroud (1997) on “Geomembrane Leakage Rate Underlain by Relatively Low Permeability Soil.” Assuming that the hydraulic head on the secondary liner is equal to or less than 1 foot, and a good installation with 3 defects per acre, the maximum leakage rate was calculated to be 14.0 gallons per minute (gpm) for Brine Pond 4. For further details, see the leakage rate calculation presented in Appendix C1.

#### **4.7. Diversion Channel**

An existing stormwater diversion channel was constructed along the northern and eastern sides of Brine Pond 1, with a high point to the north. The existing diversion channel runs west from Brine Pond 1 and ends near Jones Road. As part of the Brine Pond 4 design, the originally designed diversion channel will be completed along the northwest side of Brine Pond 4 and discharge into the end of the existing roadside channel running along the southeast side of Jones Road, as shown on Drawing A400. A v-ditch swale will be constructed along the eastern side of the access road along the east embankment to capture runoff flowing from the space between Ponds 1 and 4. See drawing A400 for Stormwater Diversion Channel details. The flow rate and velocity expected is non-erosive and therefore erosion protection measures are not required.

#### **4.8. Groundwater Monitoring**

To monitor groundwater impacts for the area, six (6) proposed monitoring well locations have been proposed around the outer perimeter of the Brine Pond facility. See Drawing A300 for the proposed locations and installation details.

#### **4.9. Brine Recovery**

The design includes sloping pipe sleeves inside the southwest corner for potential future installation of brine recovery pumps and piping. If a brine recovery pipeline is constructed in the future, solution from the pond will be recycled back to caverns to aid in the cavern operation or between Brine Ponds based on capacity conditions.



#### **4.10. Brine Influent Pipeline**

A 20-inch HDPE DR11 brine influent pipeline will be installed to Brine Pond 4 near the northernmost portion of the embankment. This pipeline will deliver all the brine that enters the pond. See Drawing A150 for details.

### **5. GEOTECHNICAL EVALUATION**

#### **5.1. Liquefaction Evaluation**

A liquefaction triggering evaluation was performed based on the penetration resistance of the foundation soils as determined by the SPT using the procedure of Idriss and Boulanger (2008). Results of this evaluation are included as Appendix F3 and indicate that only one location in the subsurface has a potential for liquefaction considering the MCE event. The location of this zone is just west of the central interior of Pond 4 at approximately 50 feet below the existing ground surface. Based on the field investigation data an approximate 5-foot layer of saturated, loose silty sand underlies the area. The layer is potentially confined by a fat clay and flowing conditions were noted during the investigation that likely influenced the penetration resistance. The remainder of the penetration data indicates that materials are either unsaturated to partially saturated, too dense, or too cohesive to liquefy. It is our assessment that any potential liquefaction during a design seismic event would be very limited, at fairly significant depth, and ultimately it would not compromise the integrity of the embankment.

#### **5.2. Brine Pond 4 Stability Evaluation**

Stability assessment of the Brine Pond 4 slopes was completed for both static and seismic conditions. Stability analyses were performed using the computer program SLIDE 2 version 9.008 by Rocscience. SLIDE is a two-dimensional slope stability program for evaluating circular or noncircular failure surfaces in soil or rock slopes using limit equilibrium methods. Spencer's procedure, which is applicable to all slope geometries and soil profiles, was utilized within the stability model and assumes all interslice forces are parallel and have the same inclination. Brine Pond 4 is considered an earthen embankment dam, and under the UAC 655-11 is required to maintain a factor of safety for static and pseudo-static conditions of 1.5 and 1.0, respectively.

To assess the stability of slopes during seismic loadings, a pseudo-static approach was utilized in which the potential sliding mass is subjected to an additional, destabilizing horizontal force that represents the effects of earthquake motions and is related to the PGA. Very simply, the seismic force is the weight of the sliding mass multiplied by a horizontal pseudo-static earthquake coefficient ( $k_H$ ).



The seismic hazard for the site was discussed in Section 3.4 of this report, and the resulting PGA for the MCE event is 0.38g. Per UAC, 100 percent of the design acceleration should be used for the stability evaluation.

### **5.2.1. Stability Model Development**

Cross-section A was cut along the Brine Pond 4 southern embankment through the sump, as shown in Appended F1, Figure 1. The location of the cross-section was selected at the tallest embankment height. The geometry of the section was developed by overlaying the existing grade with the proposed final grade. The crest width was modeled as 22-feet wide. The overall interior embankment slope was modeled as 2.5H:1V, exterior slope modeled as 2H:1V, and the impounded brine modeled at a specific gravity of 1.2 and at the crest (no freeboard). Subsurface soils were modeled with both sand and clay foundations, and groundwater depth at 22 ft as encountered during the subsurface investigation.

### **5.2.2. Material Properties**

Material properties used for the stability evaluation are summarized in Table 2. The material and strength characteristics of the sediments were developed considering the recent penetration test data (blowcounts) from the field investigation and results from recent and historic laboratory test work (IGES, 2009; 2010a; 2010b). Brine impounded within the facility was modeled as layer with no strength and was not allowed to percolate into the embankment or subsurface soils since the pond is fully lined.

Material properties of the Clay Foundation used for the End of Construction stability model are based on the lower end of the unconsolidated triaxial compression test performed by IGES (2009) and a conservative estimate from SPT correlations. The Clay Foundation properties used for the Long Term Static stability model are based on more recent test data, disregarding the cohesion intercept, adding a factor of safety with any cohesion that is present.

To investigate the potential influence of seismically induced softening, post-seismic stability was evaluated with 20 percent reduction in the strength of the foundation soil, and the output graphics from the model are shown in Appendix F1. No strength reduction was assumed for the embankment as it will be a drained, densely compacted fill.



**TABLE 2 - MATERIAL PROPERTIES USED IN THE STABILITY ANALYSES**

Material	Moist Unit Weight (lb/ft <sup>3</sup> )	Friction Angle (degrees)	Cohesion (lb/ft <sup>2</sup> )
Embankment Fill	125	30	300
Clay Foundation <sup>1</sup> (Pseudostatic, Post Seismic)	120	22	0
Clay Foundation (End of Construction)	120	0	4000
Clay Foundation (Long Term Static)	120	26	0
Sand Foundation <sup>1</sup>	110	30	0
Brine	75	0	0

Note: <sup>1</sup> A 20 percent strength reduction was utilized for post-seismic softening of the soil

### 5.2.3. Results of the Stability Evaluation

The stability analysis resulted in acceptable factors of safety for both static and pseudo-static conditions, as shown on Table 3. A non-circular failure along the exterior slope of the embankment represented the critical failure form. Circular failure forms were evaluated but determined to be less critical than the non-circular failure forms. Failure output graphics from the stability model are included in Appendix F1. Based on these results the proposed geometry of the pond embankments will remain stable under both static and pseudo-static conditions.

**TABLE 3 - SUMMARY OF CALCULATED MINIMUM FACTORS OF SAFETY**

Cross Section	Foundation Type	End of Construction Stability	Long term Static Stability	Pseudo-Static Stability (MCE Event)	Post-Seismic Stability
A	Clay	1.8	1.5	0.7	1.2
A	Sand	1.7	1.7	0.8	1.5

### 5.3. Deformation Analysis

Since the pseudo-static stability evaluation resulted in calculated factors of safety less than unity, potential seismic deformations of facility slopes were evaluated using a simplified method. Results of the deformation analysis are included in Appendix F2, and indicate that for the design event, potential slope displacements are approximately 11.5-inches for a 1 percent probability of exceedance and a very conservative evaluation of the seismic risk. It is our engineering assessment that any potential slope deformation from the design seismic event will not compromise the integrity of the embankment and the established freeboard will ensure that overtopping does not occur in the event of downward crest movement.



#### **5.4. Settlement Evaluation**

Settlement of the subgrade soils due to the embankment construction was estimated for Brine Pond 4. Settlements were assessed to quantify the range of potential vertical deformation within the foundation soils caused by the increase in static load from the facilities. Elastic parameters of the granular soils were estimated based on blowcounts from the penetration tests, and consolidation parameters for the saturated clay materials were estimated from site specific laboratory test work from the Brine Pond 1 design (IGES, 2009; 2010a; 2010b). Estimates predict that one foot of settlement or less will occur for the maximum facility loading. This estimate of potential settlement is conservative in consideration of monitoring of eight settlement monuments around Brine Pond 1. In general, the monitoring data indicates that the majority of the facility has seen a slight settlement underneath the embankments with a maximum recorded movement of 0.8-in.

To monitor the settlement of the Brine Pond 4 embankment, eight (8) settlement monuments will be installed along the crest of the embankment. See Drawing A400 for details.

#### **6. CONSTRUCTION QUALITY CONTROL AND CONSTRUCTION QUALITY ASSURANCE (CQC/CQA) PLAN**

The “Magnum CQC/CQA Plan for Construction of Brine Ponds,” prepared by Hansen, Allen & Luce, Inc., February 2013, which was used for the construction of Brine Pond 1 and is included in Appendix G.

The technical specifications included in Appendix B of this report shall supersede all technical specifications included in the Hansen, Allen & Luce CQC/CQA plan.



## 7. REFERENCES

- AMEC (2011). “Magnum Gas Storage, LLC, Evaporation Ponds Final Design Report.”
- Cardno Entrix (2013). “Groundwater Discharge Permit Application Attachment. Magnum NGLs Storage Project – Brine Evaporation Pond.”
- Giroud, J.P., Khire, M.V., and Soderman, K.L. (1997). “Liquid Migration through Defects in a Geomembrane Overlain and Underlain by Permeable Media,” Geosynthetics International, Vol. 4, Nos. 3-4, 293-321.
- Giroud, J.P. (1997). “Equations for Calculating the Rate of Liquid Migration through Composite Liners due to Geomembrane Defects,” Geosynthetics International, Vol. 4, Nos. 3-4, 335-348.
- Hansen, Allen & Luce, Inc. (2013) “Magnum CQC/CQA Plan for Construction of Brine Ponds.”
- Idriss, I.M. and Boulanger, R.W. (2008) “Soil Liquefaction during Earthquakes,” Earthquake Engineering Research Institute, MNO-12, Oakland, CA.
- IGES (2009). “Preliminary Geotechnical Investigation and 360 Acres of Preliminary On-Site Evaporation Pond Development, Magnum Gas Storage Project near Delta, Utah,” IGES Job No. 01286-001, August 11, 2009.
- IGES (2010a). “Geotechnical Investigation, Western Energy Hub Gas Storage Facility Plant Site, near Delta, Utah,” IGES Job No. 01286-004, April 19, 2010.
- IGES (2010b). “Geotechnical Investigation for Evaporation Pond Site, Magnum Gas Storage Project near Delta, Utah,” IGES Job No. 01286-002, June 2, 2010.
- NewFields. (2015). “Sawtooth Brine Pond #2, Updated Final Design Report,” dated June 5<sup>th</sup>.
- NewFields (2017). “Brine Pond Future Expansion Phase I, and Evaporation Pond Project,” Technical Memorandum, Subject: Summary of Geotechnical Field Investigation Findings, dated February 7<sup>th</sup>.
- NewFields (2017). “Magnum Gas Storage Project – Brine Ponds 3 and 4 Final Design Report,”  
Dated October 6<sup>th</sup>, 2017.
- Oviatt, C. G. (1989). “Quaternary Geology of Part of the Sevier Desert, Millard County, Utah,” Utah Department of Natural Resources, Special Studies 70.





## FIGURES

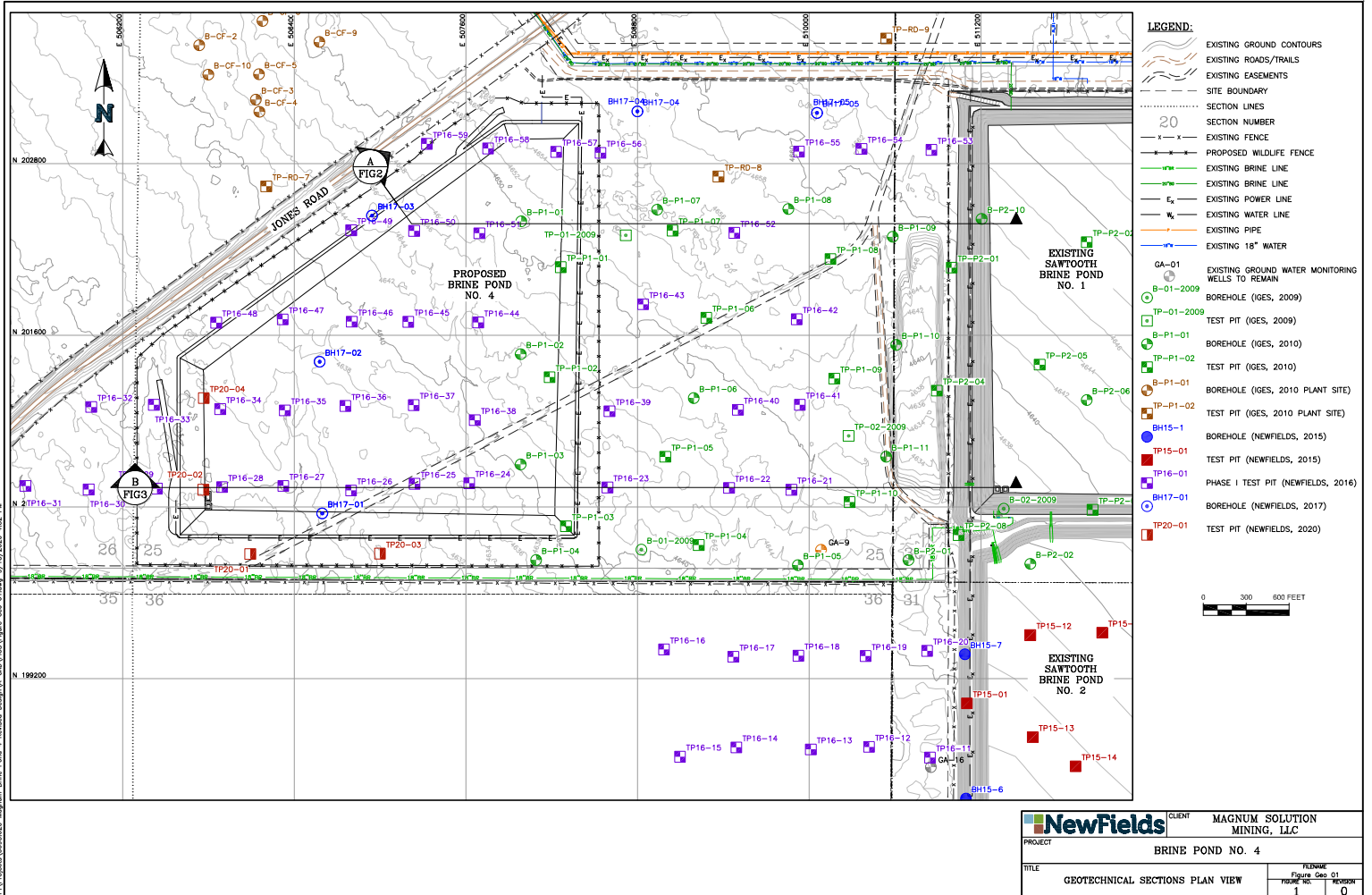

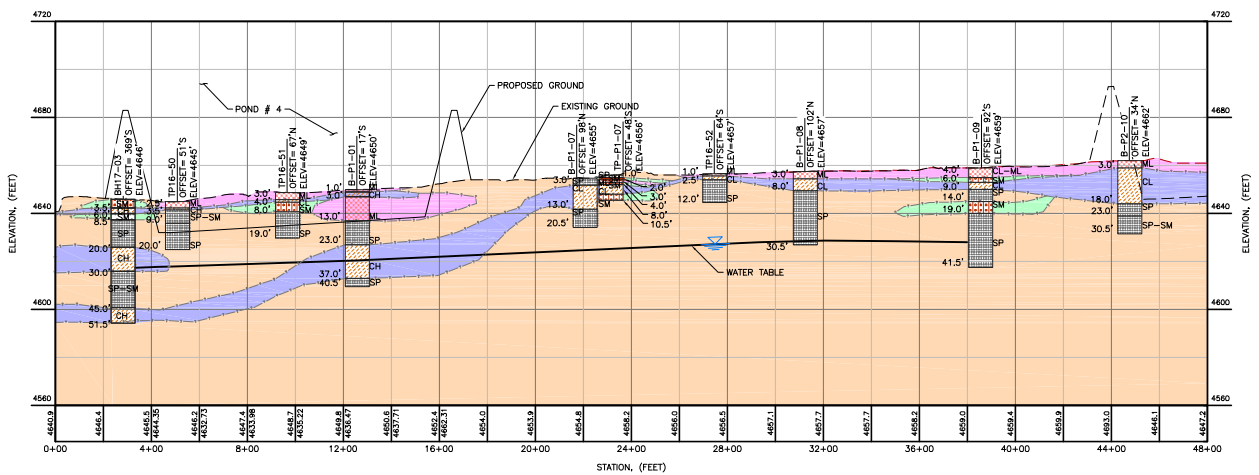

**BORING LEGEND:**

- CLAY (CL/CH)
- SILT (ML)
- POORLY GRADED SAND (SP)
- SILTY SAND (SM)
- CLAYEY SAND (SC)

**INFERRED SOIL STRATIGRAPHY:**

- CLAY DOMINATED
- SILT DOMINATED
- SAND DOMINATED
- SANDY SILT/ SILTY SAND

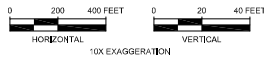

**NOTES:**

1. COLORED SHADING HAS NOT BEEN VERIFIED AND ONLY REPRESENTS MAJOR SOIL CLASSIFICATION INFERRED BY NEWFIELDS BASED ON BOREHOLE LOGS.

	CLIENT	MAGNUM SOLUTION MINING, LLC	
	PROJECT	BRINE POND NO. 4	
TITLE	GEOTECHNICAL SECTION A		TABLE Figure One_02 SHEET NO. 2 REVISION 0

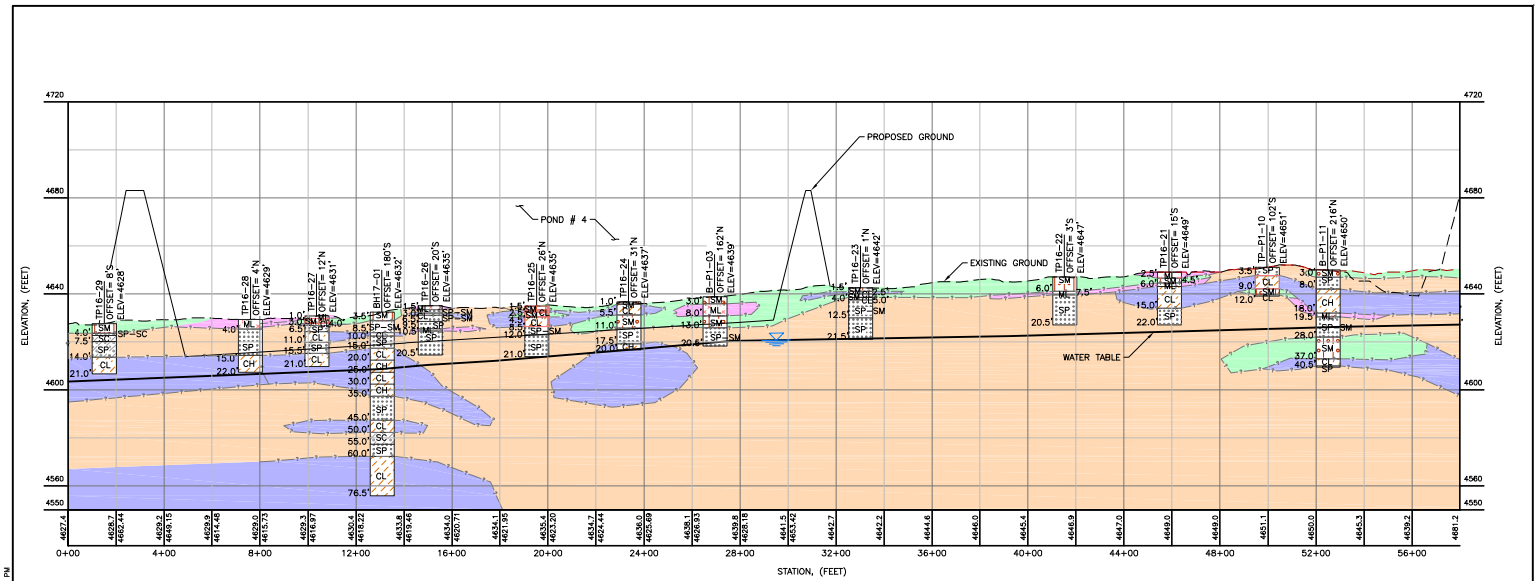

**BORING LEGEND:**

- CLAY (CL/CH)
- SILT (ML)
- POORLY GRADED SAND (SP)
- SILTY SAND (SM)
- CLAYEY SAND (SC)

**INFERRED SOIL STRATIGRAPHY:**

- CLAY DOMINATED
- SILT DOMINATED
- SAND DOMINATED
- SANDY SILT/ SILTY SAND

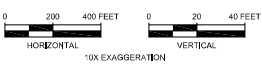

**NOTES:**

1. COLORED SHADING HAS NOT BEEN VERIFIED AND ONLY REPRESENTS MAJOR SOIL CLASSIFICATION INFERRED BY NEWFIELDS BASED ON BOREHOLE LOGS.

	CLIENT	MAGNUM SOLUTION MINING, LLC
	PROJECT	BRINE POND NO. 4
TITLE	GEOTECHNICAL SECTION B	
	TABLE	FIGURE NO.
	03	3
	REVISION	
	0	

**FIGURE 4 - Brine Pond 4 Filling Curve**

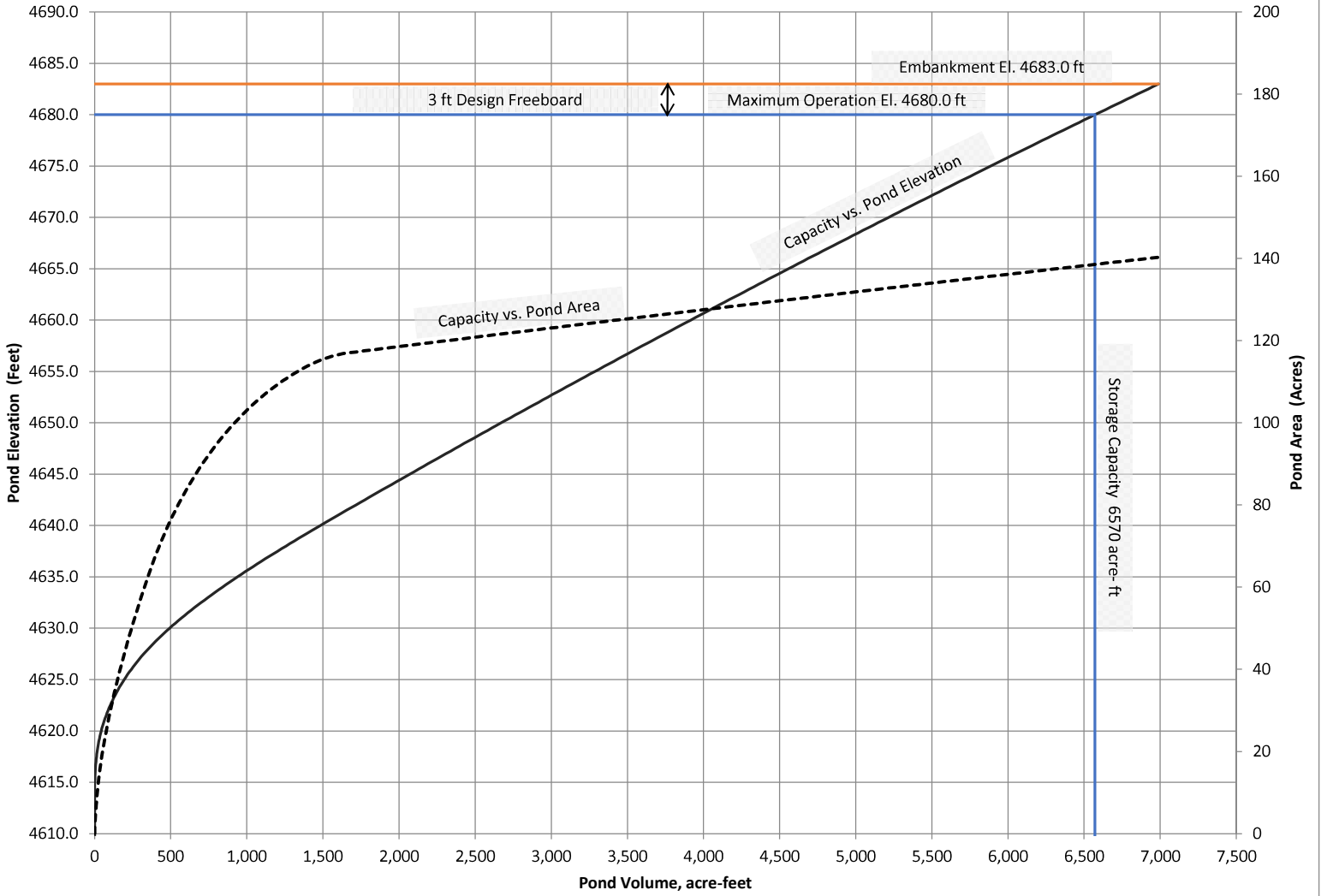



## **TABLES**























TABLE 3



Project: Magnum Development Solution Mining      2020.07.14  
 Subject: Magnum Brine Pond No. 4 Filling Table      John Weingardt

ELEVATION	CUMULATIVE AREA (AC)	CUMULATIVE VOLUME (AC-FT)	
4610.0	0	0	SUMP
4611.0	0	0	
4612.0	0	0	
4613.0	0	0	
4614.0	0	0	
4615.0	2	1	
4616.0	3	4	
4617.0	6	8	
4618.0	10	16	
4619.0	14	28	
4620.0	18	44	OPERATING
4621.0	22	64	
4622.0	27	88	
4623.0	32	118	
4624.0	38	153	
4625.0	44	194	
4626.0	50	241	
4627.0	56	294	
4628.0	63	353	
4629.0	70	419	
4630.0	76	492	
4631.0	82	571	
4632.0	87	655	
4633.0	92	745	
4634.0	97	839	
4635.0	101	938	
4636.0	104	1,040	
4637.0	108	1,146	
4638.0	111	1,256	
4639.0	113	1,368	
4640.0	115	1,482	
4641.0	117	1,598	
4642.0	117	1,715	
4643.0	118	1,833	
4644.0	118	1,951	
4645.0	119	2,069	
4646.0	119	2,188	
4647.0	120	2,308	
4648.0	121	2,428	
4649.0	121	2,549	
4650.0	122	2,671	
4651.0	122	2,792	
4652.0	123	2,915	
4653.0	123	3,038	
4654.0	124	3,161	
4655.0	124	3,286	
4656.0	125	3,410	
4657.0	125	3,535	
4658.0	126	3,661	
4659.0	127	3,788	
4660.0	127	3,914	
4661.0	128	4,042	
4662.0	128	4,170	
4662.5	129	4,234	
4663.0	129	4,298	
4664.0	129	4,428	
4665.0	130	4,557	
4666.0	131	4,687	
4667.0	131	4,818	
4668.0	132	4,950	
4669.0	132	5,082	
4670.0	133	5,214	
4671.0	133	5,347	
4672.0	134	5,481	
4673.0	135	5,615	
4674.0	135	5,750	
4675.0	136	5,885	
4676.0	136	6,021	
4677.0	137	6,158	
4678.0	137	6,295	
4679.0	138	6,433	
<b>4680.0</b>	<b>139</b>	<b>6,571</b>	4,680.0 IS THE MAXIMUM WATER SURFACE ELEVATION (3 FEET FREEBOARD)
4681.0	139	6,710	
4682.0	140	6,849	
4683.0	140	6,989	



## **APPENDIX A – DESIGN CRITERIA**



**Magnum Development Solution Mining  
Brine Pond 4  
Design Criteria**



DESCRIPTION	VALUE	SOURCE
<b>Brine Pond 4</b>		
Storm event direct precipitation, 100-year/24-hour storm event	2-in	Permitted Evaporation Pond Design <sup>1</sup>
Pond 4 Minimum Storage Volume	6500 acre-ft	MDSM <sup>2</sup>
Freeboard	3-ft design freeboard	Permitted Evaporation Pond Design <sup>1</sup>
<b>Brine Pond Features</b>		
Construction Materials	homogenous earthfill	Permitted Evaporation Pond Design <sup>1</sup>
Pond side-slopes (Inner Embankment)	2.5(Horizontal):1(Vertical)	Permitted Evaporation Pond Design <sup>1</sup>
Pond side-slopes (Outer Embankment)	2(Horizontal):1(Vertical)	MDSM <sup>2</sup>
Crest Width	22-ft	Permitted Evaporation Pond Design <sup>1</sup>
Crest Access Road Width	10.5-ft	Permitted Evaporation Pond Design <sup>1</sup>
Safety Berm Height	18-in	Permitted Evaporation Pond Design <sup>1</sup>
Design Flow - Cavern to Brine Pond 4	2,500 gpm Nominal	WSP <sup>4</sup>
Lining system	A composite system with the primary liner consisting of 80-mil (2.0mm) single sided textured HDPE liner underlain by a secondary liner consisting of a 60-mil (1.5mm) drain liner with 130-mil height raised studs facing up. 250-mil geonet may be used in lieu of the 130-mil height raised studs.	NewFields MDTs <sup>3</sup> & Permitted Evaporation Pond Design <sup>1</sup>
<b>Leak Collection and Recovery System (LCRS)</b>		
System	Drainage layer, strip drains between primary and secondary liner to transmit flows to the LCRS sump	Permitted Evaporation Pond Design <sup>1</sup>
LCRS Sump Dimensions	25-ft by 50-ft	Permitted Evaporation Pond Design <sup>1</sup>
LCRS Sump Sideslopes	2.5H:1V	Permitted Evaporation Pond Design <sup>1</sup>
Sump Basin Grading	2 percent	Permitted Evaporation Pond Design <sup>1</sup>
LCRS Sump Depth	3.5-ft	Permitted Evaporation Pond Design <sup>1</sup>
<b>Process Component Monitoring System (PCMS)</b>		
System	Trenches will be excavated beneath the secondary liner containing Cpe pipe in drainage material to transmit flows to a PCMS sump	Permitted Evaporation Pond Design <sup>1</sup>
PCMS Sump Dimensions	25-ft by 25-ft	Permitted Evaporation Pond Design <sup>1</sup>
PCMS Sump Sideslopes	2.5H:1V	Permitted Evaporation Pond Design <sup>1</sup>
PCMS Sump Depth	2-ft	Permitted Evaporation Pond Design <sup>1</sup>
<b>Geotechnical Evaluation</b>		
<b>Maximum Credible Earthquake</b>		
Annual Exceedance Probability (Return Period)	0.0002 (4975 yrs)	UAC R655-11-5A
Mean Magnitude	6.2	USGS Deagg. Tool
Rupture Distance	14.7 km	USGS Deagg. Tool
Peak Ground Acceleration	0.38g	USGS Deagg. Tool
<b>Operating Basis Earthquake</b>		
Annual Exceedance Probability (Return Period)	0.05 (200 yrs)	UAC R655-11-5A
Mean Magnitude	6.16	USGS Deagg. Tool
Rupture Distance	56.7 km	USGS Deagg. Tool
Peak Ground Acceleration	0.049g	USGS Deagg. Tool
Static Minimum Factor of Safety	≥1.5	UAC R655-11-6A
Pseudo-static Minimum Factor of Safety	≥1.0	UAC 655-11-5C
Allowance for Facility Settlement	1 ft	NewFields MDTs <sup>3</sup>

1. Permitted design for Evaporation Ponds 1 -3 is based on the "Magnum Gas Storage, LLC, Evaporation Ponds Final Design Report, May 23, 2011," by AMEC

2. Magnum Development Solution Mining

3. NewFields Mining Design and Technical Services

4. WSP USA, Inc.



## **APPENDIX B – TECHNICAL SPECIFICATIONS**



**APPENDIX B1 – TECHNICAL SPECIFICATIONS FOR EARTHWORKS  
MATERIALS AND CONSTRUCTION**



**CLIENT**  
MAGNUM SOLUTION MINING, LLC

**PROJECT NO**  
475.0093.020

**PROJECT** BRINE POND 4

**TITLE** TECHNICAL SPECIFICATIONS FOR EARTHWORKS  
MATERIALS AND CONSTRUCTION

**SPECIFICATION NO.**  
0093.020-SPT-EW-1

REV	DATE	PAGES	APPROVALS			REMARKS
			ORIGINATOR	PM/PIC	CLIENT	
0	9/15/2020	18	JW	KJ	CF	Issued for Construction
1	1/29/2021	17	JW	KJ	CF	Re-issued for Construction

**TABLE OF CONTENTS**

1.0 GENERAL ..... 1

    1.1 Definition of Terms ..... 1

2.0 EARTHWORKS ..... 2

    2.1 Control of Surface Water Runoff..... 2

    2.2 Earthwork Specifications..... 2

        2.2.1 Clearing and Stripping ..... 2

        2.2.2 Grading/Embankment and Foundation Preparation ..... 3

        2.2.3 Excavations and Borrow Areas ..... 4

        2.2.4 Fill Materials..... 6

            2.2.4.1 Random Fill ..... 7

            2.2.4.2 Select Gravel ..... 8

            2.2.4.3 Placement of Select Gravel ..... 9

            2.2.4.4 Road Wearing Coarse (Aggregate Base) ..... 9

            2.2.4.5 Pipe Bedding and Pipe Backfill - Non-Perforated Pipe,  
                    Trench Installations ..... 10

        2.2.5 Finished Surface Preparation of Areas to Receive Geomembrane  
            Lining..... 11

        2.2.6 Compaction Equipment ..... 11

            2.2.6.1 Smooth Drum Vibratory Roller ..... 12

            2.2.6.2 Tamping-Foot (“Sheepsfoot”) Roller..... 12

            2.2.6.3 Special Compactors ..... 12

            2.2.6.4 Frost Tube Installation ..... 12

3.0 QUALITY CONTROL..... 13

    3.1.1.1 Control Tests..... 13

    3.1.1.2 Record Tests ..... 13

4.0 QUALITY ASSURANCE CONSTRUCTION TOLERANCES..... 14

5.0 TESTING FREQUENCIES ..... 14



**CLIENT**  
MAGNUM SOLUTION MINING, LLC

**PROJECT NO**  
475.0093.020

**PROJECT** BRINE POND 4

**TITLE** TECHNICAL SPECIFICATIONS FOR EARTHWORKS  
MATERIALS AND CONSTRUCTION

**SPECIFICATION NO.**  
0093.020-SPT-EW-1

REV	DATE	PAGES	APPROVALS			REMARKS
			ORIGINATOR	PM/PIC	CLIENT	
0	9/15/2020	18	JW	KJ	CF	Issued for Construction
1	1/29/2021	17	JW	KJ	CF	Re-issued for Construction

**LIST OF TABLES**

Table 1 –Test Methods..... 16

Table 2 – Test Frequency – Random Fill ..... 16

Table 3 – Test Frequency – Select Gravel ..... 17

Table 4 – Test Frequency – Pipe Backfill/Pipe Bedding ..... 17

Table 5 – Test Frequency – Road Wearing Course ..... 17

Table 6 – Test Frequency – Embankment Foundation ..... 17

Table 7 – Test Frequency – Basin Foundation ..... 18





## 1.0 GENERAL

This specification defines the requirements for the earthwork construction activities for Brine Pond 4. The specifications set forth in this document cover the foundation conditioning and workmanship for earthworks construction.

Any alternatives or exceptions to this specification shall be submitted in writing to the Owner or its designated representative(s)/agent(s) and shall be approved by the Engineer.

### 1.1 Definition of Terms

- “Owner” is defined as Magnum Solution Mining LLC or any of its authorized representative(s) / agent(s).
- “Engineer” is defined as the Consultant or Engineering Company responsible for the detailed design or any of its authorized representative(s)/ agent(s).
- “Contractor” is defined as the party(s) that has executed the contract agreement for the specified Work with the Owner or its authorized representative(s)/agent(s). The Owner may elect to perform the services of the Contractor.
- “Specifications” are defined as this document, all supplemental addenda, and any modifications furnished by the Owner, the Engineer, or others that apply to the Work.
- “Drawings” are defined as the Drawings for Brine Pond 4 furnished by the Owner, Engineer, or others that apply to the Work.
- “Site” is defined as the Project site near Delta, Utah that is being developed by the Owner and where the Work is to be completed as described in these Technical Specifications and detailed on the Drawings.
- “Contract” is defined as the document executed by the Owner or its authorized representative(s)/agent(s) with the Contractor to complete specified portions of the Work.
- “Work” is defined as the entire completed construction or the various separately identifiable parts thereof required to be furnished as shown on the Drawings and as described in the Specifications and Contract Documents.
- “Modifications” are defined as changes made to the Specifications or the Drawings that are approved by Owner and Engineer in writing, after the Specifications and Drawings have been issued for construction. These also refer to changes to design elements in the field to account for unforeseen conditions.
- “Plant” is defined as all equipment, supplies, accommodations, temporary offices, etc., required to complete the Work.
- “Units” – In general, these Specifications and the Drawings will utilize English units, however metric units will be used when appropriate.



## **2.0 EARTHWORKS**

This section presents the technical requirements for the earthworks construction for Brine Pond 4.

All equipment used by the Contractor shall meet satisfactory conditions and comply with the Specifications with the approval of the Engineer. The Engineer or Owner reserves the right to request in writing a change in the required equipment or procedure of any work and the earthwork Contractor shall comply.

### **2.1 Control of Surface Water Runoff**

The surface water runoff control including temporary and permanent berms, canals and any other control measures, shall be built according to the line and grade indicated on the Drawings and maintained throughout the work.

The earthwork Contractor shall build berms, and embankments and other erosion control measures required to prevent significant run on or transport of sediments from the rock storage area, and other areas of the work that may be subject to the effects of meteoric waters.

The earthwork Contractor shall provide equipment and perform all necessary work to maintain the areas of surface water collection to remove sediments from the water before it leaves the immediate area. The Contractor shall provide the temporary erosion control measures and make improvements immediately to these control measures if deemed necessary by the Owner or Engineer. The earthwork Contractor shall prevent damage to the work areas due to drying, water runoff and sediment control.

The earthwork Contractor shall remove all temporary installations of erosion control measures when they are no longer necessary and restore the areas affected by these measures.

The earthwork Contractor shall be responsible for the damage that results from rainfall runoff and for failed erosion control measures.

## **2.2 Earthwork Specifications**

### **2.2.1 Clearing and Stripping**

The natural ground surface is to be cleared and stripped of all organic and objectionable materials to the limits shown on the Drawings or as required by the Engineer. The limits of stripping shall generally extend approximately 10 feet outside of the Work activity areas as shown on the Drawings. Any clearing and stripping beyond the limits shown on the Drawings, or as required by the Engineer, shall be subject to the approval of the Owner.



Stripping shall mean the removal of topsoil, which shall be defined as soil of any gradation or degree of plasticity that contains significant quantities of visually identifiable plant matter, sod, roots, or humus as determined by the Engineer. Over much of the facility and associated construction areas, stripping will consist of removal of the sagebrush and vegetation cover with limited removal of surface soil (approximately 6 inches) generally being required. In areas where the topsoil extends to depths greater than 6 inches, the excavations shall extend to a greater depth as directed by the Owner. The stripped material shall be hauled to stockpile areas as instructed by the Owner. Stripped surface soils and vegetation suitable for use for future reclamation purposes shall be stockpiled separately from material viewed as unsuitable for reclamation purposes.

Clearing and stripping will be carried out using whatever method is deemed necessary, providing it is consistent with producing an acceptable end result as determined by the Owner and the Engineer.

After stripping of the required area, the surface shall be treated as specified on the Drawings or in the Technical Specifications. Prior to any surface treatment on a stripped area, the Engineer shall be notified to inspect the stripped area and designate the method of treatment required for continuance of Work. A survey shall be taken of the area if necessary to determine quantities and/or for verification of lift/layer thickness.

### **2.2.2 Grading/Embankment and Foundation Preparation**

Once the work area has been cleared and stripped to the satisfaction of the Engineer, the surface shall be prepared before any overlying materials are placed. All work areas shall be graded according to the limits shown on the Drawings. Areas of both cut and fill shall be required to bring the grading of the work area to the elevations specified in the Drawings.

Areas that are to be filled within the basin area and embankment random fill zones shall have the exposed surface scarified to a depth of approximately 8 inches; moisture conditioned; and compacted to 95 percent of the maximum dry density as determined by ASTM D698 to ensure a good foundation is provided for the first lift of fill. (Note: The Engineer may waive this requirement if the exposed surface soils, without manipulating, will provide a firm, non-yielding surface for fill placement, in which case the surface shall be moistened, lightly scarified, and the first layer of fill placed.) Cut surfaces and/or natural ground surfaces, on which fill will not be placed within the basin area, shall be scarified to a depth of 8 inches; moisture conditioned; and compacted to form a firm non-yielding surface suitable for placement of the overlying geomembrane liner. Areas where in situ materials are not suitable as a geomembrane subgrade (i.e., coarse gravel and rock) shall be covered with imported, fine-grained materials, moisture conditioned, and compacted to the specified requirements.



All boulders and cobbles that are located at the surface and/or partially exposed in a finish cut or fill area that could be detrimental to the overlying construction shall be removed as directed by the Engineer.

Areas of unsuitable material as determined by the Engineer or areas of pre-existing fill not compacted to the specifications shall be excavated to the limits designated by the Engineer and replaced with compacted random fill.

The Earthwork Contractor is responsible for maintaining the surface in a satisfactory condition after approval of the Engineer. The Contractor shall protect the prepared surface from weather, construction equipment and other factors.

### **2.2.3 Excavations and Borrow Areas**

Excavation methods, techniques, and procedures shall be developed with consideration to the nature of the materials to be excavated and shall include all precautions that are necessary to preserve, in an undisturbed condition, all areas outside the lines and grades shown on the Drawings or as required by the Engineer. Excavation, shaping, etc., shall be carried out by whatever method is considered most suitable, providing it is consistent with producing an acceptable result as determined by the Engineer. Excavations shall be graded to provide drainage and prevent ponding. The water table shall be maintained at least 3-feet below subgrade level. The Contractor shall perform several test pits in the southwestern quadrant of each pond prior to construction to confirm this can be maintained during construction. For excavations that cannot be graded to drain or perched water conditions, the Contractor shall adhere to the following requirements:

- The Contractor shall furnish, install, maintain, and operate all necessary pumping equipment.
- Where required, water shall be collected into sumps located within low areas of the facility footprints. Water shall be directed out of the work area by pumping or construction of diversion channels/ditches so as to keep the work area dry.
- The surface water runoff control including temporary and permanent berms, canals and any other control measures, shall be built according to the line and grade indicated on the Drawings and maintained throughout the work.
- The earthwork Contractor shall prevent all damage to the Work areas (including adjacent downstream areas) due to drying, water runoff and sediment control.

No excavation beyond the lines and grades shown on the Drawings or as required by the Engineer shall be completed without the prior approval of the Engineer/Owner. If such additional excavation is done without prior approval and, in the opinion of the Engineer, requires backfilling to satisfactorily complete the Work, such backfilling shall be approved by



the Engineer and shall be completed at the Contractor's cost. The Contractor shall protect and maintain all excavations until the adjacent placement or overlying placement of material has been completed.

The Contractor shall coordinate borrow activities with the Engineer to allow the sampling and testing of materials prior to their excavation. The Contractor shall allow the Engineer adequate time to evaluate potential borrow materials. Materials from excavations within the works or borrow areas that meet the specified requirements for other construction materials shall be stockpiled or placed in fill areas as directed by the Engineer/Owner. Unsuitable or excess materials shall be hauled to waste or stockpile areas.

The materials obtained from borrow pits or Owner-stockpiled material shall be selected to ensure that the gradation requirements for the various construction materials are achieved and that the materials are as homogeneous as possible. Care shall be taken to avoid cross-contaminating different types of materials.

On-site borrow areas shall be developed within the limits shown on the Drawings or as required by the Owner. Should the Contractor wish to develop additional borrow sources, the Contractor shall receive written approval from the Owner prior to proceeding. Approval by the Owner may require that subsurface investigations be carried out to obtain samples as are required by the Engineer to make an appropriate assessment of the suitability of the borrow materials in the area for the intended use.

Borrow pit operations shall be subject to the approval of the Owner and Engineer and shall avoid waste of any suitable construction material therein. Clearing and stripping of any borrow area is to be completed with all salvageable topsoil stockpiled in areas designated on the Drawings or as directed by the Owner. Each borrow area shall be developed with due consideration for drainage and runoff from the excavated surfaces so as not to cause erosion of the adjacent terrain. Each borrow area shall be excavated in near-horizontal layers and in such a manner that water will not collect and pond except as approved by the Owner. Before being abandoned, the sides of any borrow areas outside the Work area shall be brought to stable slopes (not steeper than 2.5H:1V) with slope intersections rounded and contoured to provide a natural, neatly graded appearance.

Waste and topsoil piles shall be leveled, trimmed, and shaped to prevent the occurrence of ponding and concentrations of surface runoff and to provide a neat appearance. Finished slopes of the waste and topsoil stockpiles shall be graded to 2.5H:1V for interim reclamation. All surface water runoff shall be directed to available natural drainage courses.

Care shall be taken to minimize and control the generation of dust.



## 2.2.4 Fill Materials

Earthfill shall not be placed until the clearing and stripping, and required foundation preparations have been completed; and the foundation has been inspected and approved by the Engineer; and any required surveys completed.

All material used for fill shall be loaded and hauled to the placement site, dumped, spread, and leveled to the specified layer thickness. Fill shall be moisture conditioned and compacted to form a dense integral fill in accordance with the Technical Specifications and as approved by the Engineer. Care shall be taken at all times to avoid segregation of the material being placed and, if required by the Engineer, all pockets of segregated or undesirable material shall be removed and replaced with material that matches the surrounding material. All fill materials shall be free of organic and inorganic debris, organic soils, frozen material, and other deleterious materials, and shall be relocated to the designated stockpile as determined by the Owner and Engineer. The suitability of all materials intended for use in the fill shall be subject to approval by the Engineer.

If the ambient air temperature is less than 32 degrees Fahrenheit (0 degrees Celsius) for more than two (2) hours over the preceding twenty four (24) hours, the Engineer will measure the temperature of any fill materials being placed to determine if the fill is frozen. "Frozen" is defined as a mean temperature of thirty-two degrees Fahrenheit (32°F) or less. The Engineer will measure the temperature of in-place fill at depths of 3 inches and 6 inches, recording the lower of the two. Six (6) measurements will be taken per acre, and if the average is below thirty-two degrees Fahrenheit (32°F), the fill will be considered frozen. Any areas of fill that are determined to be frozen shall be removed or reconditioned, reshaped, and re-compacted by the Contractor in conformance with this Specification, at no cost the Owner. Under no circumstances shall frozen materials be incorporated as fill nor shall fill be placed on frozen ground, snow, or other surfaces that have not been approved by the Inspector.

All oversize material shall be removed from the fill material either prior to it being placed or after it is dumped and spread but prior to compaction. No additional payment will be made to remove oversized materials unless the work is specifically identified as a payment item on the Schedule of Quantities.

For most construction conditions, the fill is to be constructed in near horizontal layers with each layer being completed over the full length and breadth of the zone before placement of subsequent layers. Each zone shall be constructed with materials meeting the specified requirements and shall be free from lenses, pockets, and layers of materials that are substantially different in gradation from the surrounding material in the same zone, as determined by the Engineer.



Except in areas approved by the Engineer, where space is limited or as otherwise specified, fill shall be placed by routing the hauling and spreading units approximately parallel to the axis of fill. The hauling equipment shall be routed in such a manner that they do not follow in the same paths but spread their travel routes evenly over the surface of the fill to aid in compaction of the fill placed.

Moisture conditioning is the operation required to increase or decrease the moisture content of material to within the specified limits. If moisture conditioning is necessary, it may be carried out by whatever method the Contractor deems is suitable, provided it produces the moisture content specified in these Technical Specifications or designated by the Engineer. Moisture conditioning of the fill, and any additional mixing or blending requirements shall be at the borrow source and/or stockpile areas with only minor adjustments during fill placement. The contractor shall take the necessary measures to ensure that moisture is being distributed uniformly throughout each layer of material being placed immediately prior to compaction. Measures shall be adopted as are necessary to ensure that the designated moisture content is preserved after compaction until the overlying layer is placed.

All particles having dimensions that interfere with compaction in the fill as determined by the Engineer shall be removed from the zone in which they were placed either prior to or during compaction.

The rolling pattern for compaction of all zone boundaries or construction joints shall be such that the full number of roller passes required in one of the adjacent zones, or on one side of the construction joint, extends completely across the boundary or joint.

#### **2.2.4.1 Random Fill**

**Material Properties** - The random fill containing will have a wide range of Unified Soil Classifications and may contain significant variations in gradation and compaction properties. Random fill shall be placed in areas where the material is not required to be of uniform character and engineering properties. Random fill shall be free of roots, grass and other organic material and consist of inorganic soil from required excavations, or borrow material from other sources, as approved by the Engineer. The Random Fill material for this project shall consist primarily of sands, silts and clays. The placement of fill materials shall be closely monitored such that weaker soils such as fat clays (CH) are not placed in concentrated horizontal zones that could affect the strength of the embankment. The Engineer will determine if the material is suitable for use as fill.

Materials containing rock or cobbles, and gravel from required excavations may be used subject to the Engineer's approval and provided the rock be reasonably graded such that large void





spaces do not result. Further, the maximum size rock shall be no larger than  $2/3$  the lift thickness which is equivalent to 4 inches.

Per Table 2 in the design report, the compacted random fill shall have a drained shear strength greater than 30 degrees, and 300 psf cohesion, in general, when measured using ASTM D3080. If results do not achieve these minimum criteria, the engineer shall be notified to re-evaluate the analysis.

The random fill for the embankment will generally be borrowed from within the pond basin and will be placed by the Contractor. The Contractor shall monitor borrow sources within the pond basin by surveying to ensure that the pond basin elevations do not extend lower than the design grades.

**Placement Methods** - Random fill shall be moisture conditioned to within 2 percent of the optimum moisture content, placed in 8-inch maximum loose lifts, and compacted to 95 percent of the maximum dry density (ASTM D698). Slight variations from the specified moisture range may be acceptable subject to the acceptance of the Engineer and provided the required compacted densities are achieved. The random fill material shall be compacted with appropriate compaction equipment capable of achieving compaction through the full thickness of the lift layer. The surface of each layer of fill shall be roughened using a sheepsfoot compactor (or approved equivalent) just prior to placing the overlying layer of fill unless otherwise approved by the Engineer. Given the dry climate of the project site, additional moisture conditioning should also be expected prior to placing the overlying layer of fill.

The Engineer shall be notified immediately if any compaction issues (i.e. shearing, slicken sides, rutting, heaving or cracking, etc.) are observed. Work in the affected area shall cease until the issues can be properly inspected by the Engineer and corrective actions made.

#### **2.2.4.2 Select Gravel**

**Material Properties** - Select gravel shall be a processed or natural clean gravel material containing nonplastic fines in accordance with ASTM D4318. The select gravel shall consist of rounded processed gravels composed of hard, durable stone particles free from organic material and generally free of thin, flat, and elongated pieces.





Sieve Size (square openings)	Percent Passing (by dry weight)
2 -inch	100
1 ½ -inch	30-70
1 -inch	0-15
½ -inch	0-5

### 2.2.4.3 Placement of Select Gravel

It is anticipated that the Select Gravel material will be imported from an off-site source by the Earthworks Contractor. The material will be hauled to the project site and stockpiled at locations approved by the owner. Care shall be used while placing this material as not to damage underlying CPe pipes or geomembrane.

### 2.2.4.4 Road Wearing Coarse (Aggregate Base)

**Material Properties** - The roadway-wearing surface is to be constructed using select mine-waste material. A source for the material will be provided by the Owner. Some removal of oversized rock will be required. Wearing course shall generally conform to the following gradation requirements as determined by ASTM C136 and C117 or as approved by the Engineer.

Sieve Size (square openings)	Percent Passing (by dry weight)
4 -inch	100
3/4 -inch	50-70
No. 4	35-50
No. 16	15-40
No. 200	2-10

The plasticity index for wearing course materials shall be no greater than 15.

**Placement Methods** –Wearing Course shall be placed in a maximum 8-inch lift to 95% of the maximum dry density as determined by ASTM D698. The moisture content shall be sufficient to obtain adequate density.



### 2.2.4.5 Pipe Bedding and Pipe Backfill - Non-Perforated Pipe, Trench Installations

**Material Properties** - Pipe bedding and backfill material for foundations and corrugated metal circular culverts shall consist of materials with the following typical characteristics:

Sieve Size (square openings)	Percent Passing (by dry weight)	
	Pipe Backfill	Pipe Bedding
4 -inch	100	
3 -inch	90-100	
1-½ -inch	--	100
¾ -inch	--	90-100
No. 4	--	30-70
No. 40	--	--
No. 200	20 max	20 max
Plasticity Index	10 max	10 max

Pipe bedding and pipe backfill shall be free of organic or frozen material.

**Placement Methods** - Backfilling shall be done as soon as possible after pipe/culvert installation/construction. Suitable backfill, free from large lumps, clods, or rocks shall be placed alongside the structure in loose layers not exceeding 8-inches thick to provide a berm of compacted earth on each side of the pipe or structure (where applicable). The fill materials shall be a minimum of 5-feet wide or the width of the pipe diameter/structure but no less than required to operate the appropriate compaction equipment. Each 8-inch layer shall be moisture-conditioned, as required to facilitate compaction, and compacted to a minimum of 95 percent of the maximum dry density as determined by ASTM D698 or as directed by the Engineer.

If it is necessary to construct a haul or other vehicle road over the pipe trench, the Engineer shall be consulted prior to the initiation of trench construction for specification modification to achieve structure sufficient for such traffic loading.

Backfill shall be placed symmetrically on each side of the structure. The backfill differential on either side of the pipe shall not exceed 8-inches, or one quarter of the diameter of the structure (whichever is less).

Prior to adding each new layer of loose backfill material until minimum 12-inches of cover is obtained, an inspection shall be made of the inside of the structure for local or unequal deformation caused by the backfilling operation. Only hand-operated tamping equipment shall



be allowed within vertical planes 3-feet (approximately 1-meter) beyond the horizontal projection of the outside surfaces of the structure (or as recommended by the culvert/structure manufacturer/designer).

Backfill material shall not be placed against any concrete foundation, abutment, wing wall, or culvert until the concrete has been in place at least seven days or the compressive strength of the concrete is 75 percent of the required 28-day strength. On structures that are not permanently supported laterally and that cannot tolerate horizontal movement, internal bracing or support should be placed during backfill operations.

### **2.2.5 Finished Surface Preparation of Areas to Receive Geomembrane Lining**

Areas to receive geomembrane lining shall be free of angular particles over 3/4-inch diameter and hard objects that may damage the geomembrane. Where excessive coarse material is exposed at the surface, rock removal by appropriate methods or other surface finishing as directed by the Engineer will be required. Rough areas with depressions or loose material shall be covered with a cushion of fine-grained materials or for large depressions, with screened prepared subgrade material (passed over ½--inch mesh screen) or equivalent. A smooth drum compactor shall make a minimum of 1 pass over all areas to receive geomembrane, including the embankment slopes.

Once the Contractor believes that the prepared subgrade surface preparation is complete, an inspection will be completed by the geomembrane Liner Installation Contractor, Engineer, and Owner with the Earthworks Contractor present. Any areas requiring repairs shall be fixed by the Earthworks Contractor.

### **2.2.6 Compaction Equipment**

Sufficient compaction equipment, of the types and sizes required to complete the work, shall be provided for compaction of the various fill materials. The use of alternative equipment will be dependent upon completion of suitable test fills to the satisfaction of the Engineer to confirm that the alternative equipment will compact the fill materials to the specified density.

Compaction equipment shall be maintained in good working condition at all times to ensure that the amount of compaction obtained is a maximum for the equipment. The Contractor shall provide the Owner and Engineer a list of proposed compaction equipment to be used before commencing Work.



### **2.2.6.1 Smooth Drum Vibratory Roller**

Smooth drum vibratory rollers shall be equipped with a suitable cleaning device to prevent the accumulation of material on the drum during rolling. Each roller shall have a total static weight of not less than 20,000 pounds at the drum when the roller is standing on level ground. The drum shall be not less than 60-inches in diameter and 78-inches in width. The vibration frequency of the roller drum during operation shall be between 1,100 and 1,500 vibrations per minute, and the centrifugal force developed by the roller, at 1,250 vibrations per minute, shall not be less than 38,000 pounds.

For compaction by the vibratory roller, a single coverage shall be defined as one pass of the roller. A minimum overlap of 12-inches shall be maintained between the surfaces traversed by adjacent passes of the roller drum. During compaction, the roller shall be propelled at 2 miles per hour (mph) or lesser speed as approved by the Engineer. The power of the motor driving the vibrator shall be sufficient to maintain the specified frequency and centrifugal force under the most adverse conditions that may be encountered during the compaction of the fill. Propulsion equipment for the roller shall be adequate to propel the roller at speeds up to 4 mph.

### **2.2.6.2 Tamping-Foot (“Sheepsfoot”) Roller**

The majority of the fill may be compacted with a tamping-foot roller. The tamping foot roller shall be self-propelled and fully ballasted with a standard tamping-foot design developing 5,000 pounds in force per linear foot of width at rest on level ground or equivalent as approved by the Engineer.

### **2.2.6.3 Special Compactors**

Special compactors shall be used to compact materials that, in the opinion of the Engineer, cannot be compacted properly by the specified larger vibratory roller because of location or accessibility.

Special compaction measures shall be adopted such as hand-held or small walk behind compactors or other methods approved by the Engineer to compact fill in trenches, around structures, and in other confined areas that are not accessible to the larger vibratory roller or tamping-foot roller. Such compaction shall be to the specified density for the particular material. The material shall be placed in loose lifts that do not exceed 6-inches.

### **2.2.6.4 Frost Tube Installation**

The Contractor shall construct at least two frost tubes at opposite corners of the site to monitor frost penetration for winter shutdown events. The frost tubes shall consist of 1/4" diameter clear plastic tubing marked at 1/2" increments, placed inside a 3/8" tube (radiant heat tube),



which is placed inside a 1/2" diameter PVC pipe which is open on both ends. The water inside the inner tube shall be colored so the depth of ice is visibly obvious. The assembly shall be installed to a depth of at least 3-feet. The Contractor shall coordinate with the Engineer for other specific details.

### **3.0 QUALITY CONTROL**

The Engineer will take samples of fill materials and perform gradation, moisture content, Atterberg Limits, and field density tests on the compacted fill and any other tests that the Engineer considers necessary to ensure that the fill being placed meets the specified requirements. The results of the tests carried out by the Engineer will be final and conclusive in determining compliance with the Technical Specifications. Test Methods are listed in Table 1 of Section 5.0.

Each lift of fill will be approved by the Engineer prior to placement of additional fill materials. Sufficient time shall be allowed by the Contractor for the Engineer to carry out the required test work and interpret the test results in order to determine the acceptability of each lift. Cooperation shall be given by the Contractor, to the Owner and the Engineer, for taking samples or making tests, and such assistance shall be rendered as is necessary to enable sampling and testing to be carried out expeditiously.

Tests carried out by the Engineer will be performed in accordance with the latest test methods prescribed by the American Society for Testing and Materials (ASTM) and other such recognized industry standards. The tests shall include Control and Record Tests.

#### **3.1.1.1 Control Tests**

Tests for gradation, moisture content, moisture density relationship, and other tests, where applicable, will be made by the Engineer on samples of fill materials taken from borrow areas and on the fill after spreading and prior to compaction at frequencies sufficient to ensure that the fill material is in full compliance with the Technical Specifications.

#### **3.1.1.2 Record Tests**

The Engineer will conduct field density, moisture content, and other tests on the compacted in-place fill and will obtain samples of the compacted fill for related laboratory testing at such frequency as the Engineer considers necessary to determine that the compacted fill is in full compliance with the Technical Specifications.



#### 4.0 QUALITY ASSURANCE CONSTRUCTION TOLERANCES

The Contractor shall construct the various aspects of the evaporation ponds to the lines and grades shown on the Drawings, or as required by the Engineer, within the following tolerances:

- Finish grades and slopes for the embankment and basin shall be in general conformance with the Drawings. Deviations from finished grades/slopes are subject to approval by the Engineer and shall not result in low spots; pockets; non-uniform slopes or contours; or result in slopes, which deviate by more than 1 percent from the design; or result in slopes of less than 1/2 percent within the basin
- The maximum permissible combined horizontal and vertical deviation of the perimeter boundaries of the embankment from the lines and grades shown on the Drawings or as required by the Engineer shall be 36 inches
- The finished surface of the basin prepared surface shall not deviate vertically by more than 4 inches than the lines and grades shown on the drawings.
- The elevation and width of the embankment crest shall not be less than the dimensions shown on the Drawings or required by the Engineer

All pipes shall be constructed to the following tolerances:

- Alignment and grade shall not deviate more than 5 percent of the nominal diameter of the pipe from a straight line between control points.

#### 5.0 TESTING FREQUENCIES

The Engineer will carry out frequent quality control/assurance tests as described herein to determine compliance of the Work with the Technical Specifications. The latest edition of standard procedures shall be used for all activities, and in general, these will be adopted from recognized organizations such as the American Society of Testing and Materials (ASTM). The following tables outline the test methods and the minimum testing requirements for the project:



**Table 1  
 Test Methods**

Test	Type of Test	Test Method (ASTM)
C1, R1	Atterberg Limits	D4318
C2, R2	Moisture Content	D2216
C3, R3	Particle Size Distribution	D422 <sup>a</sup>
C4, R4	Laboratory Compaction-Std. Proctor	D698
R5a	Nuclear Density	D2922
R5b	Sand Cone	D1556
R5c	Water Replacement	D5030
C6, R6	Direct Shear Strength	D3080

**Notes:** C = Control Tests; R = Record Tests

<sup>a</sup> Hydrometer tests down to the 2-micron size will be carried out as directed by the QA Engineer but will generally not be required; all samples to be washed over a No.200 sieve.

**Table 2  
 Test Frequency – Random Fill**

Test	Type of Test	Frequency (one per)
R1	Atterberg Limits	10,000 yd <sup>3</sup>
C2, R2	Moisture Content <sup>(1)</sup>	1 per lift per day or 2,000 yd <sup>3</sup>
C3, R3	Particle Size Distribution	10,000 yd <sup>3</sup>
C4, R4	Laboratory Compaction	Soil type/ 1 per 10 field density tests
R5a	Nuclear Density <sup>(1)</sup>	1 per lift per day or 2,000 yd <sup>3</sup>
R5b/R5c	Sand Cone or Water Replacement Density	1 per 10 nuclear density tests
C6, R6	Direct Shear Strength	1 per 1,000,000 yd <sup>3</sup>

**Note:** Required number of tests shall be determined by whichever method of determining the frequency requires the most tests.

**(1)** If three consecutive moisture-density tests fail for either non-conforming compaction or moisture conditions, then the testing frequency will be increased to 1 per 1,000 yd<sup>3</sup> until 6 acceptable tests in a row are recorded.



**Table 3**  
**Test Frequency – Select Gravel**

Test	Type of Test	Frequency (one per)
C1, R1	Atterberg Limits	1,000 yd <sup>3</sup>
C3, R3	Particle Size Distribution	1,000 yd <sup>3</sup> or minimum of 2 tests
<b>Note: Sample sizes to be sampled in accordance with ASTM standards.</b>		

**Table 4**  
**Pipe Backfill/Pipe Bedding**

Test	Type of Test	Frequency (one per)
R1	Atterberg Limits	Soil type/5,000 yd <sup>3</sup> or 1 per structure
C2, R2	Moisture Content	per nuclear density requirements
C3, R3	Particle Size Distribution	5,000 yd <sup>3</sup> or 1 per structure
C4, R4	Laboratory Compaction	Soil type/5,000 yd <sup>3</sup>
R5a	Nuclear Density	Greater of 4 per structure or 500 yd <sup>3</sup>
R5b	Sand Cone Density	every 10 nuclear density tests

**Table 5**  
**Test Frequency – Road Wearing Course**

Test	Type of Test	Frequency (one per)
R1	Atterberg Limits	2,000 yd <sup>3</sup>
R3	Particle Size Distribution	2,000 yd <sup>3</sup>

**Table 6**  
**Test Frequency – Embankment Foundation**

Test	Type of Test	Frequency (one per)
R1	Atterberg Limits	Soil type/100,000 ft <sup>2</sup>
C2, R2	Moisture Content	50,000 ft <sup>2</sup>
C3, R3	Particle Size Distribution	100,000 ft <sup>2</sup>
C4, R4	Laboratory Compaction	Soil type/250,000 ft <sup>2</sup>
R5a	Nuclear Density	50,000 ft <sup>2</sup>
R5b	Sand Cone Density	1 per 10 nuclear density tests





**Table 7**  
**Test Frequency – Basin Foundation**

<b>Test</b>	<b>Type of Test</b>	<b>Frequency (one per)</b>
R1	Atterberg Limits	Soil type/200,000 ft <sup>2</sup>
C2, R2	Moisture Content	100,000 ft <sup>2</sup>
C3, R3	Particle Size Distribution	200,000 ft <sup>2</sup>
C4, R4	Laboratory Compaction	Soil type/500,000 ft <sup>2</sup>
R5a	Nuclear Density	100,000 ft <sup>2</sup>
R5b	Sand Cone Density	1 per 10 nuclear density tests



## **APPENDIX B2 – TECHNICAL SPECIFICATIONS FOR CORRUGATED POLYETHYLENE PIPE (CPEP) MATERIALS AND INSTALLATION**



**CLIENT**  
MAGNUM SOLUTION MINING, LLC

**PROJECT NO**  
475.0093.020

**PROJECT** BRINE POND 4

**TITLE** TECHNICAL SPECIFICATIONS FOR CORRUGATED POLYETHYLENE PIPE (CPeP) MATERIALS AND INSTALLATION

**SPECIFICATION NO.**  
0093.020-SPT-CPeP-0

REV	DATE	PAGES	APPROVALS			REMARKS
			ORIGINATOR	PM/PIC	CLIENT	
0	9/15/2020	5	JW	KJ	CF	Issued for Construction

**TABLE OF CONTENTS**

1.0 GENERAL ..... 1

    1.1 Definition of Terms ..... 1

    1.2 Codes and Standards..... 2

    1.3 Material Properties ..... 2

        1.3.1 Corrugated Polyethylene Pipe (CPeP) with Smooth Interior ..... 2

    1.4 Submittals ..... 4

    1.5 Pipe Delivery, Handling, and Storage ..... 4

    1.6 Pipe Installation ..... 4



## 1.0 GENERAL

This specification defines the requirements for Corrugated Polyethylene Pipe (CPeP) materials, installation, and quality control for Brine Pond 4.

Any alternatives or exceptions to this specification shall be submitted in writing to the Owner or its designated representative(s)/agent(s) and shall be approved by the Engineer.

### 1.1 Definition of Terms

- “Owner” is defined as Magnum Solution Mining LLC or any of its authorized representative(s) / agent(s).
- “Engineer” is defined as the Consultant or Engineering Company (NewFields) responsible for the detailed design or any of its authorized representative(s)/ agent(s).
- “Contractor” is defined as the party(s) that has executed the contract agreement for the specified Work with the Owner or its authorized representative(s)/agent(s).
- “Specifications” are defined as this document, all supplemental addenda, and any modifications furnished by the Owner, the Engineer, or others that apply to the Work.
- “Drawings” are defined as the Construction Drawings for Brine Pond 4 furnished by the Owner, Engineer, or others that apply to the Work.
- “Site” is defined as the Project site near Delta, Utah that is being developed by the Owner and where the Work is to be completed as described in these Technical Specifications and detailed on the Drawings.
- “Contract” is defined as the document executed by the Owner or its authorized representative(s)/agent(s) with the Contractor to complete specified portions of the Work.
- “Work” is defined as the entire completed construction or the various separately identifiable parts thereof required to be furnished as shown on the Drawings and as described in the Specifications and Contract Documents.
- “Modifications” are defined as changes made to the Specifications or the Drawings that are approved by Owner and Engineer in writing, after the Specifications and Drawings have been issued for construction. These also refer to changes to design elements in the field to account for unforeseen conditions.
- “Plant” is defined as all equipment, supplies, accommodations, temporary offices, etc., required to complete the Work.
- “Units” – In general, these Specifications and the Drawings will utilize English units, however metric units will be used when appropriate.



## 1.2 Codes and Standards

All pipe work shall be of the best quality available complying with the latest standards for the following:

- ANSI American National Standard Institute
- ASTM American Society of Testing and Materials
- AWWA American Water Works Association
- AASHTO American Association of State Highway Officials
- SPI Society of the Plastics Industry, Inc.
- PPI Plastics Pipe Institute

## 1.3 Material Properties

### 1.3.1 Corrugated Polyethylene Pipe (CPEP) with Smooth Interior

Pipe and fittings shall be made of virgin polyethylene compounds that conform with the applicable current edition of the AASHTO Material Specifications for cell classification as defined and described in ASTM D 3350. Resins that have higher cell classifications in one or more properties, with the exception of density, are acceptable provided the product requirements are met.

For slow crack growth resistance, acceptance of resins shall be determined by using the notched constant tensile load (NCTL) test in accordance with ASTM F2136 except that the applied stress for the NCTL test shall be 600 psi (Note: The notched depth of 20 percent of the nominal thickness of the specimen is critical to this procedure). The average failure time of the five test specimens must exceed 24 hours with no single test specimen's failure time less than 17 hours.

Pipe and fittings shall be manufactured and comply with the current edition of AASHTO Standard Specifications M252 and M294. All sizes shall conform to the AASHTO classification "Type S" for smooth wall interior solid pipe and "Type SP" for smooth wall interior perforated pipe.

CPE pipe and couplings for watertight application shall be Advanced Drainage System ADS N12 WT IB. Prefabricated fittings for the watertight application shall have bell ends suitable for connecting to the pipe or alternatively shall have plain ends suitable for using bell-to-bell push-on gasketed couplings.



The pipe shall have a minimum pipe stiffness of 5-percent deflection when tested in accordance with ASTM D2412, as follows:

Nominal Diameter (inches)	Pipe Stiffness (psi)
4	70
6	65
8	60
10-12	50
15	42
18	40
24	34
30	28
36	22
42	20
48	18
60	14

The diameters refer to the inside pipe diameter.

Where perforations are specified, they shall conform to the requirements as follows:

- AASHTO M252 “Class 2” for 4-inch to 10-inch diameter CPeP (Max slot width = 0.125in)
- AASHTO M294 “Class 2” for 12-inch to 36-inch diameter CPeP

Couplings (non-watertight) shall be corrugated to match the pipe corrugations and shall provide sufficient longitudinal strength to preserve pipe alignment and prevent separation at the joints. Couplings, unless watertight connections are specified, shall be split collar and shall engage at least two full corrugations on each pipe section. Where pipe is joined to other materials or fittings, or joined by other methods, the manufacturer’s recommendations shall be strictly enforced.

CPeP-to-HDPE pipe connections, if specified, shall be made using CPeP-to-HDPE adapters supplied by the CPeP manufacturer. The HDPE pipe end of the adapter shall match the DR (Dimensional Ratio) of the pipe being connected.

Pipe sizes and types shall be as specified on the Drawings, or as required by the Engineer.



## **1.4 Submittals**

The CPeP material supplier shall submit to the Owner, upon request, a manufacturer's certification that all pipe and fittings they intend to supply comply with the applicable portions of the specifications.

## **1.5 Pipe Delivery, Handling, and Storage**

Pipe, fittings, valves, and other appurtenances shall be loaded and unloaded by lifting with hoists in such a manner as to avoid damage or hazard. Under no circumstances shall pipe or pipe fittings be dropped to the ground or into trenches. Pipe handled on skid ways shall not be skidded or rolled against pipe already on the ground. The interior of all pipe and pipe fittings shall be kept free from dirt and foreign material at all times.

The Earthworks Contractor shall be responsible for any material furnished to him by the Owner and shall replace or repair, in a manner approved by the Engineer at the Earthworks Contractor's expense, all such material damaged in handling after delivery. This shall include the furnishing of all materials and labor required for the replacement of installed material damaged prior to the final acceptance of the Work.

## **1.6 Pipe Installation**

CPe pipe shall be installed to the sizes, lines, and grades shown on the Drawings. Pipe sections shall be joined with manufacturer-supplied couplers with the open seam of the coupler turned to the side of the pipe. End caps shall be installed on the upstream ends of the pipe. Pipes shall be closely monitored during backfilling activities to ensure no damage is done to the pipe.

The pipe shall be installed to the lines and grades and generally in the manner shown on the Drawings. Where specific lines and grades are not indicated on the Drawings, the lines and grades will be determined by the Engineer in the field to suit the existing ground conditions. The Earthworks Contractor shall use equipment and methods acceptable to the Engineer and in accordance with the pipe manufacturer's recommendations for handling and placement of the pipe and fittings.

The Earthworks Contractor shall provide and install all piping required to complete the piping installation in accordance with good piping practices, regardless of whether such piping is specifically detailed on the Drawings. The general layout as shown on the Drawings shall be maintained. Where interference is encountered during installation or relocation of pipelines is deemed necessary, the Engineer shall be consulted before any changes are made.



All pipelines shall be erected to preserve accurate alignment. Care shall be taken in the installation of pipeline runs where drainage is required to ensure that the pipeline has a continuous slope to the point of drainage.

Prior to installation, each segment of pipe and all fittings shall be inspected for defects and/or damage. All pipe, fittings, and other appurtenances shall be carefully lowered into position, piece by piece. Under no circumstances shall such materials be dropped into position. Extreme care shall be taken to prevent foreign material from entering the pipe while it is being installed. Temporary end caps or other approved means shall cover open ends of the pipe when installation is not in progress.

Pipe bends to form curves either in the horizontal or vertical plane shall not exceed that recommended by the manufacturer or approved by the Engineer. The cutting of pipe for inserting fittings or closure pieces shall be done in a neat manner and with good workmanship without damage to the pipe and leaving a smooth end at right angles to the axis of the pipe.

Wherever obstructions not shown on the plans are encountered during construction, and where such obstructions interfere with the work to an extent that an alteration in the lines or grades of the pipe is required, the Engineer shall approve any deviation or arrange for removal, relocation, or reconstruction of the obstructions.





## **APPENDIX B3 – TECHNICAL SPECIFICATIONS FOR HDPE PIPE MATERIALS AND INSTALLATION**



**CLIENT**  
MAGNUM SOLUTION MINING, LLC

**PROJECT NO**  
475.0093.020

**PROJECT** BRINE POND 4

**TITLE** TECHNICAL SPECIFICATIONS FOR HIGH DENSITY POLYETHYLENE (HDPE) PIPE AND FITTINGS MATERIALS AND CONSTRUCTION

**SPECIFICATION NO.**  
0093 020-SPT-HDP-0

REV	DATE	PAGES	APPROVALS			REMARKS
			ORIGINATOR	PM/PIC	CLIENT	
0	9/15/2020	7	JW	KJ	CF	Issued for Construction

**TABLE OF CONTENTS**

1.0 GENERAL ..... 1

    1.1 Definition of Terms ..... 1

    1.2 Codes and Standards..... 2

    1.3 HDPE Materials ..... 2

        1.3.1 Strip Drain ..... 4

    1.4 Submittals ..... 4

    1.5 Pipe Delivery, Handling, and Storage ..... 4

    1.6 Pipe Installation ..... 5

        1.6.1 General ..... 5

        1.6.2 Joining..... 6

            1.6.2.1 Heat Fusion..... 6

            1.6.2.2 Other Methods of Joining..... 6

        1.6.3 Marking..... 6

        1.6.4 Testing..... 7

**LIST OF TABLES**

Table 1 - Physical Material Properties For HDPE Pipe (PE 4710) ..... 3



## 1.0 GENERAL

This specification defines the requirements for High-Density Polyethylene (HDPE) PE4710 pipe materials, installation, and quality control associated for Brine Pond 4.

Any alternatives or exceptions to this specification shall be submitted in writing to the Owner or its designated representative(s)/agent(s) and shall be approved by the Engineer.

### 1.1 Definition of Terms

- “Owner” is defined as Magnum Solution Mining LLC or any of its authorized representative(s) / agent(s).
- “Engineer” is defined as the Consultant or Engineering Company (NewFields) responsible for the detailed design or any of its authorized representative(s)/ agent(s).
- “Third Party Testing Contractor” is defined as the Consultant or Engineering Company (to be determined) hired by the owner to provide third party inspection and testing services for the overall project.
- “Contractor” is defined as the party(s) that has executed the contract agreement for the specified Work with the Owner or its authorized representative(s)/agent(s).
- “Specifications” are defined as this document, all supplemental addenda, and any modifications furnished by the Owner, the Engineer, or others that apply to the Work.
- “Drawings” are defined as the Drawings for Brine Pond 4 furnished by the Owner, Engineer, or others that apply to the Work
- “Site” is defined as the Project site near Delta, Utah that is being developed by the Owner and where the Work is to be completed as described in these Technical Specifications and detailed on the Drawings.
- “Contract” is defined as the document executed by the Owner or its authorized representative(s)/agent(s) with the Contractor to complete specified portions of the Work.
- “Work” is defined as the entire completed construction or the various separately identifiable parts thereof required to be furnished as shown on the Drawings and as described in the Specifications and Contract Documents.
- “Modifications” are defined as changes made to the Specifications or the Drawings that are approved by Owner and Engineer in writing, after the Specifications and Drawings have been issued for construction. These also refer to changes to design elements in the field to account for unforeseen conditions.
- “Plant” is defined as all equipment, supplies, accommodations, temporary offices, etc., required to complete the Work.
- “Units” – In general, these Specifications and the Drawings will utilize English units, however metric units will be used when appropriate.



## 1.2 Codes and Standards

All pipework shall be of the best quality available complying with the latest standards for the following:

- ANSI American National Standard Institute
- ASTM American Society of Testing and Materials
- AWWA American Water Works Association
- AASHTO American Association of State Highway Officials
- SPI Society of the Plastics Industry, Inc.
- PPI Plastics Pipe Institute SPI
- IPS Iron Pipe Sizing

## 1.3 HDPE Materials

Materials used for the manufacture of high-density polyethylene (HDPE) pipe and fittings shall have a standard thermoplastic material designation code of PE 4710 and comply with all requirements for ASTM D3350. The pipe shall contain no recycled compound except that generated in the manufacturer's own plant from the resin of the same specification and from the same raw material supplier. The dimensional and performance characteristics shall conform to the requirements of ASTM F714 for sizes 4-inches IPS and larger and conform to ASTM D3035 for sizes smaller than 4-inches IPS. In addition, materials used for the manufacture of the HDPE pipe and fittings shall meet the following physical property requirements listed in the table below:



**Table 1**  
**Physical Material Properties for HDPE Pipe (PE 4710)**

Property	Unit	Standard	Nominal Value
Material Designation	-	ASTM F412	PE 4710
Cell Classification	-	ASTM D3350	445474 C (black)
Density (Natural)	gm/cc	ASTM D1505	0.947
Density (Black)	gm/cc	ASTM D1505	0.959
Melt Index	gm/10 minutes	ASTM D1238	< 0.08
Flexural Modulus	Psi	ASTM D790	140,000
Tensile Strength @ Ultimate	Psi	ASTM D638	5,000
Tensile Strength @ yield	Psi	ASTM D638	>3,600
PENT	hours	ASTM F1473	>500
ESCR	hours	ASTM D1693	>10,000
HDB at 73°F (23°C)	Psi	ASTM D2837	1,600
Color; UV Stabilizer	% C	ASTM D1603	Black with minimum 2% carbon black Color with UV Stabilizer
Modulus of Elasticity (long term)	Psi	ASTM D638	30,000

The pipe manufacturer's quality control system shall be certified by an appropriate independent body to meet the requirements of the ISO 9002 Quality Management Program.

The 4-inch perforated HDPE pipe shall be shop perforated with ½" holes spaced 6-inches apart and staggered with holes located 120-deg from one another. If possible, the 4-inch pipe should be received on rolls to minimize field fusing.

All stub ends/flange adapters, shall be of at least the same wall thickness and pressure rating and the same resin type and manufacturer as the pipe to be joined, unless otherwise approved. Backing flanges for HDPE pipe shall be the convoluted type of ductile iron material (ASTM A536 grade range from 60/40/18 to 65/45/12, drilled to ANSI bolt circles, and have a pressure rating of 150 psi) unless otherwise approved by the **Engineer**.

Fabricated fittings intended for use in non-pressure or low pressure services may be manufactured from the same diameter and DR rating as used in the piping system (Note: The pressure rating of these fittings will be approximately only 75 percent of the straight pipe of the same DR). Fittings not intended for use in pressure service shall be clearly marked or tagged.



Fabricated fittings intended for use in pressure service shall meet or exceed the design pressure of the piping system and be fabricated from pipe of at least the next numerically smaller dimension ratio unless otherwise shown on the Drawings. Ends shall be machined to match the joining pipe DR.

Where HDPE and corrugated polyethylene (CPE) pipes are connected, manufactured fittings shall be used unless approved otherwise by the **Engineer**. All other joints shall be fused or flange-jointed as shown on the Drawings. Flange assembly bolts, when specified as machine bolts, shall conform to the requirements of ASTM A307, Grade A standard, square-head machine bolts conforming to ASME/ANSI B 18.2.1 with heavy hot-pressed hexagon nuts. Bolt length shall be such that, after joints are made up, bolts shall protrude through the nut by at least than ½ inch.

Stud bolts, when specified, shall be ASTM A193 Grade B7 with two-hex head nuts, ASTM A194 Grade 2H per each for above ground service and ASTM A193 Grade B8 with Stainless Steel nuts in accordance with ASTM A194. Alternately, commercial Grade 18-8 Stainless Steel bolts and nuts may be used for buried service.

Gaskets shall be used at all flanged connections and shall be full face, black nitrile rubber gaskets (Garlock style 9122 or equal), and 1/8 inch thick.

### 1.3.1 Strip Drain

Strip drains shall be 18-inches wide with a flow rate capacity of a minimum of 21 gpm/ft at a hydraulic gradient of 0.1. They shall not crush under a compressive load of 4,500 psf. The strip drain shall not have a geotextile wrapping. The material shall be either Terradrain Strip Drain 600, or the AdvanEDGE Strip Drain. NewFields shall provide approval prior to procurement and installation.

## 1.4 Submittals

The **Contractor's** HDPE pipe supplier shall submit to the **Owner** test data for each lot and a manufacturer's certification that all pipe and fittings under their supply comply with the applicable portions of the specifications.

## 1.5 Pipe Delivery, Handling, and Storage

Pipe, fittings, valves, and other appurtenances shall be loaded and unloaded by lifting with hoists in such a manner as to avoid damage or hazard. The interior of all pipe and pipe fittings shall be kept free from dirt and foreign material at all times.



The **Contractor** shall be responsible for all material furnished to him and shall replace or repair, in a manner approved by the **Engineer**, at the **Contractor's** expense, all such material damaged in handling after delivery by the **Owner**. This shall include the furnishing of all materials and labor required for the replacement of installed material discovered damaged prior to the final acceptance of the work.

## 1.6 Pipe Installation

### 1.6.1 General

The pipe shall be installed to the lines and grades and generally in the manner shown on the Drawings. Where specific lines and grades are not indicated on the Drawings, the lines and grades will be determined, by the Engineer in the field, to suit the existing ground conditions. The **Contractor** shall use equipment and methods acceptable to the **Engineer and Third Party Testing Contractor** and in accordance with the pipe manufacturer's recommendations for handling and placement of the pipe and fittings.

The **Contractor** shall provide and install all piping required to complete the piping installation in accordance with good piping practices, regardless of whether such piping is specifically detailed on the Drawings. The general layout as shown on the Drawings shall be maintained. Where interference is encountered during installation or relocation of pipelines is deemed necessary, the **Engineer** shall be consulted before any changes are made.

All pipelines shall be erected to preserve accurate alignment. Care shall be taken, in the installation of pipeline runs where drainage is required, to ensure that the pipeline has a continuous slope to the point of drainage.

Prior to installation, each segment of pipe and all fittings shall be inspected for defects and/or damage. All pipe, fittings, and other appurtenances shall be carefully lowered into position, piece by piece. Under no circumstances shall such materials be dropped into position. Extreme care shall be taken to prevent foreign material from entering the pipe while it is being installed. Temporary end caps or other approved means shall cover open ends of the pipe when installation is not in progress.

Wherever obstructions not shown on the plans are encountered during the construction and where such obstructions interfere with the work to the extent that an alteration in the lines or grades of the pipe is required, the **Engineer** shall approve any deviation or arrange for removal, relocation, or reconstruction of the obstructions.



## 1.6.2 Joining

### 1.6.2.1 Heat Fusion

Pipe and fittings shall be joined by one of the following types of thermal fusion in accordance with the manufacturer's recommended procedures: butt fusion, saddle fusion, or socket fusion.

Upon request, the manufacturer shall provide fusion training by authorized personnel or an authorized representative. The **Contractor** shall be responsible for ensuring that personnel have received proper training in accordance with the manufacturer's recommended procedure. Records of training shall be maintained by the **Contractor** and evidence of training shall not exceed 12 months from date of construction.

Butt fusions performed between pipe ends or pipe ends and fitting outlets shall be within the following allowable wall mismatches:

- 2 DR difference for pipe and fitting diameters 6-inch IPS and smaller
- 1 DR difference for above 6-inch through 18-inch
- No difference for diameters above 18-inch.

The difference in DR is determined from the following DR values: 7.3, 9, 11, 13.5, 17, 21, 26, and 32.5.

### 1.6.2.2 Other Methods of Joining

Polyethylene pipe and fittings where heat fusion is not possible may be joined together or to other materials through the use of electrofusion fittings; flange adapters with backup rings; mechanical couplings designed for connecting polyethylene pipe and fittings to itself or to another material; or Mechanical Joint (MJ) adapters. All alternative joining methods and devices shall be approved by the Engineer. The manufacturer of the joining device shall be consulted for proper installation procedures.

## 1.6.3 Marking

Pipe and tubing shall be permanently marked in accordance with all applicable standards in accordance with this Specification. Marking, as follows, shall be continuously (or spaced at intervals not exceeding 5 feet) heat-stamped indent print and shall remain legible under normal handling and installation practices:

1. Name and/or trademark of the pipe manufacturer.
2. Nominal pipe size





3. Dimension Ratio

4. The letters PE followed by the polyethylene grade per ASTM D3350, followed by the Hydrostatic Design basis in 100's of psi, e.g., PE4710
5. Manufacturing Standard Reference, e.g., ASTM F714
6. A production code from which the date and place of manufacture can be determined

Fittings shall be marked on the body or hub. Marking shall be in accordance with the applicable standard depending on the fitting type. Marking on the fitting shall include the following whenever possible:

1. Nominal size and Outside Diameter (OD) base (such as 12-inch IPS)
2. Standard material code designation (such as PE 4710)
3. Dimension ratio
4. Pressure class if for pressure service

Mechanical fittings shall be marked with size, body material designation code, pressure rating, and the manufacturer's name or trademark.

#### 1.6.4 Testing

The **Contractor** shall be responsible for field setup and performance of the fusion equipment and the fusion procedure used by the operator. Upon request, the **Contractor** shall verify the fusion quality by marking and testing in accordance with the manufacturer's recommended qualification procedure or by using Time-of-Flight ultrasonic testing. The **Contractor** shall be responsible for the necessary adjustments to the setup, equipment, operation, and fusion procedure. Fusions that fail the qualification procedure shall be remade.

Hydrostatic testing shall be conducted if required by the **Owner** to a minimum of 110 percent of the maximum operating pressure or design pressure, whichever is greater.



**APPENDIX B4 – TECHNICAL SPECIFICATIONS FOR GEOMEMBRANE  
MATERIALS AND CONSTRUCTION**

			<b>CLIENT</b> MAGNUM SOLUTION MINING, LLC			<b>PROJECT NO</b> 475.0093.020
<b>PROJECT</b> BRINE POND 4						
<b>TITLE</b> TECHNICAL SPECIFICATIONS FOR GEOMEMBRANE MATERIALS AND CONSTRUCTION					<b>SPECIFICATION NO.</b> 0093.020-SPT-GM-1	
<b>REV</b>	<b>DATE</b>	<b>PAGES</b>	<b>APPROVALS</b>			<b>REMARKS</b>
			<b>ORIGINATOR</b>	<b>PM/PIC</b>	<b>CLIENT</b>	
0	9/15/2020	17	JW	KJ	CF	Issued for Construction
1	1/29/2021	17	JW	KJ	CF	Re-Issued for Construction
<b>TABLE OF CONTENTS</b>						
1. GENERAL ..... 1						
1.1 Definition of Terms ..... 1						
1.2 References ..... 2						
1.2.1 American Society for Testing and Materials (ASTM): ..... 2						
1.2.2 Geosynthetic Research Institute (GRI): ..... 2						
2. GEOMEMBRANE..... 3						
2.1 Manufacturer’s Quality Control ..... 3						
2.2 Submittals Post-Award..... 4						
2.3 Third Party Conformance Testing..... 5						
3. GEOMEMBRANE INSTALLATION..... 5						
3.1 General ..... 5						
3.2 Geomembrane Installation Quality Control ..... 7						
3.2.0 General ..... 7						
3.2.1 Trial Welds ..... 8						
3.2.2 Field Seaming..... 9						
3.2.3 Field Seam and Panel Inspection and Testing ..... 9						
Nondestructive Testing and Inspection ..... 9						
Continuity Testing..... 9						
Destructive Testing..... 12						
3.2.4 Repair Procedures..... 13						
4. CERTIFICATION ..... 14						
5. COMPLETION ..... 14						

		<b>CLIENT</b> MAGNUM SOLUTION MINING, LLC			<b>PROJECT NO</b> 475.0093.020	
<b>PROJECT</b> BRINE POND 4						
<b>TITLE</b> TECHNICAL SPECIFICATIONS FOR GEOMEMBRANE MATERIALS AND CONSTRUCTION					<b>SPECIFICATION NO.</b> 0093.020-SPT-GM-1	
<b>REV</b>	<b>DATE</b>	<b>PAGES</b>	<b>APPROVALS</b>			<b>REMARKS</b>
			<b>ORIGINATOR</b>	<b>PM/PIC</b>	<b>CLIENT</b>	
0	9/15/2020	17	JW	KJ	CF	Issued for Construction
1	1/29/2021	17	JW	KJ	CF	Re-Issued for Construction
<b>TABLE OF CONTENTS (Continued)</b>						
<b>LIST OF TABLES</b>						
Table 1 – HDPE Geomemembrane - Smooth .....						15
Table 2 – HDPE Geomembrane - Textured.....						16
Table 3 – Seam Strength and Related Properties of Thermally Bonded Smooth and Textured HDPE Geomembranes .....						17
Table 4 – Raw Material Properties .....						17



## 1. GENERAL

This specification defines the requirements for geomembrane materials, installation, and quality control associated with the Brine Pond 4.

Any alternatives or exceptions to this specification shall be submitted in writing to the Owner or its designated representative(s)/agent(s) and shall be approved by the Engineer.

### 1.1 Definition of Terms

- “Owner” is defined as Magnum Solution Mining LLC or any of its authorized representative(s) / agent(s).
- “Engineer” is defined as the Consultant or Engineering Company (NewFields) responsible for the detailed design or any of its authorized representative(s)/ agent(s).
- “Construction Manager” is defined as the Consultant or Engineering Company responsible for the overall project completion.
- “Third Party Testing Contractor” is defined as the Consultant or Engineering Company (to be determined) hired by the owner to provide third party inspection and testing services for the overall project.
- “Contractor” is defined as the party(s) that has executed the contract agreement for the specified Work with the Owner or its authorized representative(s)/agent(s).
- “Installer” is defined as the qualified 3<sup>rd</sup> party(s) that have been hired to install the geomembrane for the specified Work.
- “Specifications” are defined as this document, all supplemental addenda, and any modifications furnished by the Owner, the Engineer, or others that apply to the Work.
- “Drawings” are defined as the Construction Drawings for Brine Pond 4 furnished by the Owner, Engineer, or others that apply to the Work.
- “Site” is defined as the Project site near Delta, Utah that is being developed by the Owner and where the Work is to be completed as described in these Technical Specifications and detailed on the Drawings.
- “Contract” is defined as the document executed by the Owner or its authorized representative(s)/agent(s) with the Contractor to complete specified portions of the Work.
- “Work” is defined as the entire completed construction or the various separately identifiable parts thereof required to be furnished as shown on the Drawings and as described in the Specifications and Contract Documents.
- “Modifications” are defined as changes made to the Specifications or the Drawings that are approved by Owner and Engineer in writing, after the Specifications and Drawings have been issued for construction. These also refer to changes to design elements in the field to account for unforeseen conditions.



- “Plant” is defined as all equipment, supplies, accommodations, temporary offices, etc., required to complete the Work.
- “Units” – In general, these Specifications and the Drawings will utilize English units, however metric units will be used when appropriate.

## 1.2 References

### 1.2.1 American Society for Testing and Materials (ASTM):

- ASTM Standard D4437, 1988 (1999), “Standard Practice for Determining the Integrity of Field Seams Used in Joining Flexible Polymeric Sheet Geomembranes”, ASTM International, West Conshohocken, PA, 1999, DOI: 10.1520/D4437-99, [www.astm.org](http://www.astm.org).
- ASTM Standard D5199, 2001 (2006), “Standard Test Method for Measuring the Nominal Thickness of Geosynthetics”, ASTM International, West Conshohocken, PA, 1999, DOI: 10.1520/D5199-01R06, [www.astm.org](http://www.astm.org).
- ASTM Standard D5641, 1994 (2006), “Standard Practice for Geomembrane Seam Evaluation by Vacuum Chamber”, ASTM International, West Conshohocken, PA, 1999, DOI: 10.1520/D5641-94R06, [www.astm.org](http://www.astm.org).
- ASTM Standard D5820, 1995 (2006), “Standard Practice for Pressurized Air Channel Evaluation of Dual Seamed Geomembranes”, ASTM International, West Conshohocken, PA, 1995, DOI: 10.1520/D5820-95R06, [www.astm.org](http://www.astm.org).
- ASTM Standard D5994, 1994 (2003), “Standard Test Method for Measuring Core Thickness of Textured Geomembrane”, ASTM International, West Conshohocken, PA, 1994, DOI: 10.1520/D5994-98R03, [www.astm.org](http://www.astm.org).
- ASTM Standard D6365, 1999 (2006), “Standard Practice for the Non-destructive Testing of Geomembrane Seams using the Spark Test”, ASTM International, West Conshohocken, PA, 1999, DOI: 10.1520/D6365-99R06, [www.astm.org](http://www.astm.org).
- ASTM Standard D6392, 2010 (2012), “Standard Test Method for Determining the Integrity of Nonreinforced Geomembrane Seams Produced Using Thermo-Fusion Methods”, ASTM International, West Conshohocken, PA, 1999, DOI: 10.1520/D6392-10R12, [www.astm.org](http://www.astm.org).
- ASTM Standard 7240, 2006 (2011), “Standard Practice for Leak Location using Geomembranes with an Insulating Layer in Intimate Contact with a Conductive Layer via Electrical Capacitance Technique (Conductive Geomembrane Spark Test)”, ASTM International, West Conshohocken, PA, 2006, DOI: 10.1520/D7240-06R11, [www.astm.org](http://www.astm.org).

### 1.2.2 Geosynthetic Research Institute (GRI):

- GRI GM6 2017: “Pressurized Air Channel Test for Dual Seamed Geomembranes”, Geosynthetic Institute, Folsom, PA, [www.geosynthetic-institute.org](http://www.geosynthetic-institute.org).



- GRI GM 9, 1995, “Cold Weather Seaming of Geomembranes”, Geosynthetic Institute, Folsom, PA, [www.geosynthetic-institute.org](http://www.geosynthetic-institute.org).
- GRI GM 10, 1997 (2006), “The Stress Crack Resistance of HDPE Geomembrane Sheet”, Geosynthetic Institute, Folsom, PA, [www.geosynthetic-institute.org](http://www.geosynthetic-institute.org).
- GRI GM 13, 1997 (2009), “Test Properties, Testing Frequency for High Density Polyethylene (HDPE) Smooth and Textured Geomembranes”, Geosynthetic Institute, Folsom, PA, [www.geosynthetic-institute.org](http://www.geosynthetic-institute.org).
- GRI GM 14, 1998, “Selecting Variable Intervals for Taking Geomembrane Destructive Seam Samples Using the Method of Attributes”, Geosynthetic Institute, Folsom, PA, [www.geosynthetic-institute.org](http://www.geosynthetic-institute.org).
- GRI GM 17, 2000 (2009), “Test Methods, Test Properties and Testing Frequency for Linear Low Density Polyethylene (LLDPE) Smooth and Textured Geomembranes”, Geosynthetic Institute, Folsom, PA, [www.geosynthetic-institute.org](http://www.geosynthetic-institute.org).
- GRI GM 19, 2002 (2010), “Seam Strength and Related Properties of Thermally Bonded Polyolefin Geomembranes”, Geosynthetic Institute, Folsom, PA, [www.geosynthetic-institute.org](http://www.geosynthetic-institute.org).

## 2. GEOMEMBRANE

The geomembrane used for Brine Pond 4 shall be the following:

- Primary Liner consisting of 80-mil (2.0mm) Single Sided Textured High Density Polyethylene (HDPE)
- Secondary Liner consisting of 60-mil (1.5mm) High Density Polyethylene (HDPE) Drain liner with 130 mil high raised studs facing up. 250-mil Geonet may be used in lieu of the 130-mil height raised studs.

### 2.1 Manufacturer’s Quality Control

The HDPE geomembrane shall be a high quality formulation containing approximately 97 percent polymer and 3 percent carbon black with antioxidants and heat stabilizers. It shall be resistant to ultraviolet (UV) rays. All resin shall be hexene-based, consist of all virgin material from the same manufacturer, shall not be intermixed, and no reclaimed polymer may be added to the resin. The manufacturing process shall not use more than 10 percent rework. If rework is used, it must be similar HDPE to the parent material.

The geomembrane material shall comprise HDPE material manufactured of new, first-quality products designed and manufactured specifically for the purpose of liquid containment in hydraulic structures as applied to the mining industry. The material shall be produced to be free of holes, blisters, undispersed raw materials, or any sign of contamination by foreign matter. The geomembrane shall be supplied in roll form. Each roll shall be identified with labels indicating roll number, thickness, length, width, and manufacturer’s name and date of manufacture.



The manufacturer's laboratory must be certified by Geosynthetic Accreditation Institute (GAI)/Laboratory Accreditation Program (LAP) for the tests being performed and shall have a third-party independent quality assurance program. The third party shall perform the required tests at the required frequency as stated in this specification or at such frequency as mutually agreed by the **Owner**, the **Engineer**, and the manufacturer at the time of award. All test results shall be provided to the **Engineer** and the rolls of material shall be clearly identified and correlate to the test results.

Extrudate rod or bead material shall be made from the same type of resin as the geomembrane and be from the same resin supplier as the resin used for manufacture of the geomembrane.

The material shall be warranted against manufacturer's defects as well as degradation due to UV light for exposed areas for a minimum of 20 years from the date of installation or as mutually agreed prior to award of the contract for supply between the **Owner** and the geomembrane manufacturer. This warranty shall cover the cost of material, freight and duties, handling, labor, and equipment to replace the defective or failed material.

## 2.2 Submittals Post-Award

The manufacturer shall furnish the following product data, in writing, to the **Owner** and the **Engineer** prior to shipment of the geomembrane material:

- Resin data including the following:
- Certification stating that the resin meets the specification requirements and that it is all from the same manufacturer (see Table 4).
- Statement certifying no reclaimed polymer and no more than 10% rework of the same type of material is added to the resin (product run may be recycled).
- Copy of quality assurance and quality control certificates issued by resin supplier.
- All rolls shall be delivered with labels affixed to the selvage edge clearly stating the manufacturer's name, product identification, material thickness, roll number, roll type, roll dimensions and roll weight.

Geomembrane roll, extrudate rod and bead material:

- Copy of quality assurance and quality control certificates issued by the geomembrane manufacturer and the HDPE third-party independent quality assurance tester.
- Certification that the geomembrane material delivered to the project complies with these specifications.





- Certification that extrudate rod or bead is from one manufacturer, is the same resin type, and was obtained from the same resin supplier as used to manufacture the geomembrane rolls.

## 2.3 Third Party Conformance Testing

- During manufacturing of the geomembrane, samples are obtained and forwarded to the Geomembrane Quality Assurance Testing Laboratory by a third party (to be determined by the Engineer and Owner) for testing to ensure conformance with the Specifications.
- Samples shall be taken across the entire width of the roll and shall not include the first 3 feet. Unless otherwise stated, samples shall be 3 feet long by the width of the roll. Unless otherwise stated, samples shall be taken at a frequency of no less than one per 2,000,000 square feet or one per lot, whichever is less.
- The conformance tests shall be performed to verify conformance to the design Specifications as listed on Tables 1 for smooth geomembrane and Table 2 for textured geomembrane.

## 3. GEOMEMBRANE INSTALLATION

### 3.1 General

The HDPE geomembrane shall be installed on the areas shown on the Drawings or as directed by the **Engineer**. The **Installer** shall be an approved installer by the Manufacturer.

Prior to deployment of geomembrane, the **Installer** shall inspect and accept, with the **Engineer**, **Third Party Testing Contractor** and the **Owner**, all surfaces on which the geomembrane is to be placed. The surface on which the geomembrane is to be installed shall be free of sharp particles, rocks, or other debris to the satisfaction of the **Engineer**, the **Owner**, and the **Installer**. Sharp objects shall be removed by raking, sweeping, or handpicking as necessary.

The **Installer** shall supply the **Engineer** with panel layouts of the liner that must be approved by the **Engineer** prior to commencing the Work. It is the **Installer's** responsibility to submit timely proposals (allowing a minimum of two weeks for approval).

Installation of the geomembrane shall be performed under the direction of a field engineer or supervisor who has installed a minimum of 10,000,000 square feet (ft<sup>2</sup>) of the specified type of geomembrane or similar. Seaming shall be performed under the direction of a Master Seamer (who may also be the Field Installation Supervisor or Crew Foreman) with seaming experience of a minimum of 3,000,000 ft<sup>2</sup> of the geomembrane type specified or similar product, using the same type of seaming apparatus to be used in the current project. During the seaming, the Field Installation Supervisor or Master Seamer are present. Qualified technicians employed by the **Installer** complete all seaming, patching, testing, and other welding operations.



The geomembrane shall be placed over the prepared surfaces using methods and procedures that ensure a minimum of handling. Adequate temporary and permanent anchoring devices and ballasting shall be provided to prevent uplift and damage due to winds. The **Installer** is solely responsible for the safety of his operations including decisions regarding deployment in adverse weather conditions and the amount of temporary anchoring and ballasting required. The **Contractor** shall take necessary precautions to protect the geomembrane from any damage including prohibiting workers from smoking and wearing foot apparel that would damage the membrane.

To the extent possible, seams shall be oriented parallel to the fall line, slope or grade of the ground. The panels shall be secured temporarily with sandbags or other approved ballasting method to hold them in place until the field seams have been completed and the geomembrane has been permanently anchored. Ballast material shall conform to the specified requirements for drainage material.

The **Installer** shall take into account that high winds are prevalent at the project site and may result in liner damage and delays. The **Installer** shall take all necessary measures to ensure that each panel is sufficiently ballasted to prevent damage or movement by wind. Fusion of panels and repairs will only be permitted under weather conditions allowing such work, and within the warranty limits of the geomembrane manufacturer, as approved by the **Owner** and the **Engineer**.

Horizontal field seams on slopes shall be kept to a minimum and require the approval of the **Engineer**. Horizontal seams on steep slopes shall be avoided where possible by cutting the liner at a 45-degree angle. Generally, horizontal seams are to be no closer than 10-feet from the toe of the slope. Horizontal seams shall be made by lapping the uphill material over the downhill material. Panels shall be shingled in a manner that prevents water from running beneath the liner.

The geomembrane shall be installed in a relaxed condition and shall be free of tension or stress upon completion of the installation. The installed geomembrane shall contain sufficient slack material to allow for thermal expansion and contraction during the annual extreme temperatures the geomembrane is expected to endure. Individual wrinkles should take the form of undulations in the liner but should not be large enough for the material to fold over on itself.

During installation, the **Installer** shall give each field panel an “identification” code number consistent with the layout plan. The **Third Party Testing Contractor** shall agree upon the numbering system. The **Installer** shall update the layout plan as each panel is installed to show the location of each panel. A field panel is defined as the area of geomembrane that is to be seamed in the field (roll or portion of a roll cut in the field).



Individual panels of geomembrane material shall be laid out in a pattern that will produce the least number of seams. The material shall be overlapped prior to welding. Extreme care shall be taken by the **Installer** in the preparation of the areas to be welded. The joint interface shall be cleaned and prepared according to industry standard procedures, those specified by the material manufacturer and those approved by the **Engineer**. Seaming shall not take place unless the panels are dry and clean. All sheeting shall be welded together by thermal methods.

Any area showing damage due to excessive scuffing, puncture, or distress from any cause shall be replaced or repaired with an additional piece of geomembrane. The cost of replacing or repairing the geomembrane shall be borne solely by the **Installer**.

No “fish mouths” will be allowed within the seam area. Where “fish mouths” occur, the material shall be cut, overlapped, and an overlap extrusion weld applied.

Geomembrane panels must have a finished overlap of 4 to 6-inches for double-wedge welding seams and minimum 6-inches for extrusion welding seams. Notwithstanding this provision, sufficient overlap shall be provided to allow shear and peel tests to be performed on any seam.

Handling and storage of the geomembrane material shall be in accordance with the manufacturer’s printed instructions. Persons walking or working on the geomembrane shall not engage in activities or wear foot apparel that could damage the geomembrane.

An adequate amount of handling equipment, welding apparatuses, and test equipment shall be maintained on site to avoid delays due to problems with equipment failures.

## 3.2 Geomembrane Installation Quality Control

### 3.2.0 General

The **Installer** shall submit a copy of his Quality Control Manual to the **Engineer** and **Owner** prior to the start of installation of any geomembrane. If there are discrepancies between this specification and the **Installer’s** Quality Control Manual, the more stringent requirements will apply unless determined otherwise by the **Engineer**.

The **Installer** shall be fully responsible for carrying out all quality control tests on the geomembrane and shall do so to the satisfaction of the **Engineer** and in accordance with this Specification and the **Installer’s** Quality Control Manual. On-site physical nondestructive and destructive testing shall be completed on all joints to ensure that watertight uniform seams are achieved on a continuous basis as installation proceeds. The **Third Party Testing Contractor** shall be present and witness all destructive tests. At the time of bid submission, details shall be provided by the **Installer** that set forth the method proposed for both destructive and



nondestructive testing of seams. The **Engineer** shall approve these methods prior to the **Installer** commencing the Work. Visual inspection alone is unacceptable.

Fusion of panels and repairs will only be permitted under weather conditions allowing work that is in conformance to the Specifications and within the warranty limits imposed by the manufacturer and to the approval of the **Engineer**.

At a minimum, the **Installer's** field installation test program shall consist of visual observations and continuity and strength tests as defined in the following subsections. The **Installer** shall not have more than 500,000 square feet of geomembrane deployed at any time without final QA/QC and acceptance by the **Third Party Testing Contractor**. At the beginning of each day's work, the **Installer** shall provide the **Third Party Testing Contractor** with copies of all the previous days' completed paperwork as well as an update of the quantity and location of geomembrane placed.

### 3.2.1 Trial Welds

Trial welds shall be completed to verify the performance of the welding equipment and operator prior to performing production welds. No welding equipment or operator shall perform production welds until equipment and operator have successfully completed a trial weld and approved by the **Third Party Testing Contractor**. The following procedures shall be followed for trial welds:

- Make trial welds under the same surface and environmental conditions as the production welds, i.e., in contact with subgrade and similar ambient temperature.
- Minimum of two trial welds per day per welding apparatus – one made prior to the start of work and one completed at mid-shift or for every 5 hours of seaming operations.
- Cut five 1-inch-wide-by-6-inch long test strips from the trial weld.
- Quantitatively test specimens for peel adhesion and for bonded seam strength (shear).
- Trial weld specimens shall pass when the results shown in Table 3 are achieved in both peel and shear tests and:
  - The break, when peel testing, occurs by Separation in the Plane of the sheet (SIP), not through adhesion failure separation (AD). When the seam separation is equal to or greater than 25% of the track width, it is a failed test.
  - The break is ductile.
- Repeat the trial weld, in its entirety, when the trial weld samples fail in either peel or shear as defined on Table 3.



### 3.2.2 Field Seaming

The **Installer** shall have at least one Master Welder who shall provide direct supervision to other welders. The Master Welder's and other welder shall submit a description of their qualifications and experience to the **Owner and Engineer** for approval prior to arrival on site.

- The welding equipment shall be capable of continuously monitoring and controlling the temperatures in the zone of contact where the machine is actually fusing the material to ensure changes in environmental conditions will not affect the integrity of the weld.
- The seam area shall be cleaned of dust, mud, moisture, and debris immediately ahead of the welding apparatus.
- The seam overlaps shall be aligned consistent with the requirements of the welding equipment being used. A 4-inch to 6-inch overlap shall be used for double-wedge welded seams and 6-inches for extrusion welded seams unless approved otherwise by the **Engineer**.
- Seaming shall not proceed when the ambient air temperature or adverse weather conditions jeopardize the integrity of the geomembrane installation. If adverse weather prevents work from being completed then the installer shall make-up the work during a scheduled day off. If enough adverse weather causes the schedule to extend beyond the agreed upon completion date then the **Owner** may compensate the **Contractor** for delays beyond their control.
- Extrusion welding apparatus' shall be purged of heat-degraded extrudate before welding.
- The double-wedge fusion welding process shall be used unless alternate methods are approved by the **Engineer**. Extrusion welding shall be permitted to weld short seams to repair small areas where double-wedge welding is not feasible, and for caps and patches.

### 3.2.3 Field Seam and Panel Inspection and Testing

#### Nondestructive Testing and Inspection

The **Installer** shall perform visual inspections of deployed and welded HDPE panels to identify defects, damage, or protrusion of sharp objects that may affect the integrity of the geomembrane. Defective or damaged areas shall be marked and repaired according to the technical specifications and the guidelines in the **Installer's** Quality Control Manual.

A quality control technician or field engineer acting for the **Installer** and **Third Party Testing Contractor** shall inspect each seam, marking his initials and date inspected at the end of each panel. Any area showing a defect shall be marked and repaired in accordance with the applicable repair procedures.

#### Continuity Testing

A maximum effort shall be made by the **Installer** to install a perfect geomembrane liner. This implies that all seams completed in the field, patches, and extrusions shall be tested and



recorded. All failures shall be isolated and repaired as directed by the **Engineer and Third Party Testing Contractor**. A general testing procedure for the **Installer** is included as follows:

- Test all field seams and patches with interseam pressure, vacuum box, spark tester, or other approved methods. Non-destructive testing methods are discussed in following subsections.
- Isolate and repair all areas indicating any leakage. Retest the repair.

**Interseam Pressure Testing.** Test procedure in accordance with ASTM D 5820 for interseam pressure for seams (for double-wedge welding only):

- Seal both ends of the seam to be tested by applying heat to the end of the seam via a heat gun until flow temperature is achieved. Clamp off the ends and let cool.
- Insert a pressure gauge with needle assembly into the end of the seam and seal.
- Pressurize the air channel between the two seams to between 30 psi and 35 psi. Following pressure stabilization, take the initial pressure reading, hold the pressure a minimum of 5 minutes and take a second reading.
- The allowable leak-down for the seam is 3 psi maximum.
- If the pressure does not drop below the maximum allowable 3 psi, open the air channel at the end away from the pressure gauge. Air should rush out and the pressure gauge should register an immediate drop in pressure, indicating that the entire length of seam has been tested. If this does not happen, either the air channel is blocked or the equipment is faulty, and the test is not valid.
- Enter the results of the leak test on the appropriate documentation, indicating either a passed or a failed seam. If the seam fails, the repair work and subsequent testing should be recorded on the same document.
- Repair the area where the pressure gauge/needle assembly was installed and where the air was released.

**Vacuum Box Testing:** Where possible, the **Installer** shall test all extrusion seams as follows:

- Mix a solution of liquid detergent and water and apply an ample amount to the area to be tested. If a seam contains excess overlap or loose edges, it must be trimmed before testing.
- Place a rigid transparent vacuum box over the area and apply a slight amount of downward pressure to the box to seat the seal strip to the liner.
- Apply a vacuum of minimum 5 psi for a minimum of 15 seconds to the area. The **Installer** shall examine the geomembrane through the viewing window for the presence of soap bubbles indicating a leak. If no bubbles appear after 15 seconds, consider the area leak free. Once the area is leak free, depressurize the box and move it over the next adjoining area with an appropriate overlap and repeat the process.



- Enter the results of the leak test on the appropriate documentation, indicating either a passed or a failed seam. If the seam fails, the repair work and subsequent testing should be recorded on the same document.

**Spark Testing:** Extrusion welded patches, caps, pipe boots, etc., in lieu of being vacuum-box testing, shall be spark tested in accordance with ASTM D 6365 and the following procedures:

- The seam shall be prepared for extrusion welding in accordance with the **Installer's** procedures.
- Just prior to applying the extrusion bead, a small-gauge copper wire (18-gauge bare copper wire or equivalent) shall be placed into the seam. The wire should be grounded at one end and placed at the edge of the top sheet of the overlap seam. Tucking the wire under the edge of the top sheet will help hold the wire in place during welding, but this should be done prior to grinding to avoid the risk of contamination of the weld area. Electrically conductive tape placed along the edge of the overlying patch can also be used instead of copper wire.
- Apply the extrudate bead as normal and allow the weld to cool.
- Complete a calibration test on a trial seam containing a non-welded segment ensuring the identification of such a defect (non-welded segment) under the planned spark tester settings and procedures.
- Energize the spark tester and move the electrode wand near the trial seam to determine the maximum length of spark that can be generated. Adjust the output voltage setting until the spark length exceeds the greatest potential leak path distance. This is typically the diagonal distance from the embedded wire to the edge of the weld bead at a "T" joint.
- Once the output voltage has been set testing may be started. Testing is performed by passing the electrode over the seams with the electrode in contact with the membrane or the extruded weld bead. The audible and visual indication of a spark provides the determination of a potential leak path.
- If a potential leak is detected the area can be repaired with a patch. Applying additional weld beads adjacent to the leaking weld is not an acceptable repair technique. This will only lengthen the leak path to the extent that the spark tester may not be capable of generating a spark of sufficient length to breach the lengthened gap.
- After patching, the seam must be retested until no defects are indicated.
- Enter the results of the spark test on the appropriate documentation, indicating either a passed or a failed seam. If the seam fails, the repair work and subsequent testing should be recorded on the same document.
- When flammable gasses are present, use special care and precautions in the area to be tested.





## Destructive Testing

Peel and shear seam strength testing shall be carried out on samples of seams removed from the installed panels. For these tests, the following procedures shall be followed:

- Coupon sampling of all field seams, including patches and repair areas, shall be taken by cutting perpendicular to the seams a sample approximately 36-inch by 12-inch. This sample shall be cut into three 12-inch by 12-inch samples and labeled with the sample number, date, time, location and seam number, and individually marked “**Owner (Archive) Sample,**” “**QA (Third Party Testing Contractor) Sample,**” and “**Installer QC Sample.**” The frequency and location shall be determined by the **Third Party Testing Contractor** but shall not be less than one sample per 500-feet of field seams. These coupons shall be tested by the Installer on-site for peel and shear seam strength and thickness in accordance with ASTM D6392.
- Heat-welded seams shall be allowed to cool or warm to about 70°F prior to testing. Solvent seams, when used, shall be allowed to cure according to the manufacturer’s recommendations. Additionally, at the **Engineer’s** option, approximately 10 percent of the coupons (size 1-inch by 6-inches) shall be sent to an independent laboratory for confirmation testing. Should the lab and field tests conflict, installation shall halt until the conflict is resolved to the satisfaction of the **Engineer.**

The **Third Party Testing Contractor** shall continuously inspect the installation of the HDPE liner to ensure that the procedures specified in this section are adhered to fully.

Weld specimens shall pass the requirements for shear and peel presented in Table 3 and as follows:

- During testing, the break shall occur by Separation in the Plane of the sheet (SIP) not through adhesion failure separation (AD). When the seam separation is equal to or greater than 25% of the track width, it is a failed test.
- The break is ductile.

In the event of a failing test result, the following procedures shall be used:

- The Installer shall follow one of two options:
- Reconstruct the seam between any two passed test locations, or
- Trace the weld to an intermediate location at least 10-feet or to where the seam ends in both directions from the location of the failed test. Once the failing limits of the seam are isolated, that portion of the seam shall be reconstructed or capped.





Seams welded prior to and after the failed seam using the same welding device and/or operator shall also be tested.

- Enter the results of the destructive testing on the appropriate documentation, indicating either a passed or a failed seam. If the seam fails, the repair work and subsequent testing should be recorded on the same document.

### 3.2.4 Repair Procedures

Damaged or defective geomembrane or seam areas failing a destructive or non-destructive test shall be repaired. Each repair requires a non-destructive test using either a vacuum box or spark testing methods. The **Installer** shall be responsible for repair of damaged or defective areas. The repair method shall be decided by the **Installer** but must be agreed upon by the **Third Party Testing Contractor**. Procedures available include the following:

- Replacement: Remove damaged geomembrane or unacceptable seam and replace with acceptable geomembrane materials if the damage cannot be satisfactorily repaired.
- Patching: Used to repair large holes, tears, undispersed raw materials, and contamination by foreign matter.
- Capping: Used to repair large lengths of failed seams.

Abrading and rewelding of small seam areas and welding the flap on fusion-welded seams are not acceptable repair procedures and shall not be accepted.

In addition, the following procedures shall be observed:

- Surfaces of the polyethylene that are to be repaired by extrusion welds shall be lightly abraded to ensure cleanliness.
- All geomembrane shall be clean and dry at the time of repair.
- Extend patches or caps at least 6-inches for extrusion welds and 4-inches for wedge welds beyond the edge of the defect, and round the corners of the patch material. The edges of all patches are to be beveled.

Furthermore, repair verification shall be performed as follows:

- Number, date, location, technician and test outcome of each patch.
- Non-destructively test each repair using methods specified in this technical specification.
- Enter the results of the repair procedures on the appropriate documentation, indicating the repair verification. If the repair fails, the repair work and subsequent testing should be recorded on the same document.



#### 4. CERTIFICATION

At the completion of the geomembrane installation, the **Installer** shall provide the **Engineer** and **Owner** with a certification stating that the geomembrane was installed and tested in accordance with the technical specifications together with a report of the test results. The certification shall be provided to the **Owner** prior to the demobilization of the installation personnel from the site unless agreed otherwise by the **Owner**. The report of the test results shall be provided in hard copy and digital format to the **Owner** and the **Engineer** no later than 30 days after the installation work has been completed.

#### 5. COMPLETION

At the completion of the installation, the **Installer** shall provide a set of as-built drawings showing the actual geomembrane panel layout, seams, location of destructive test samples, and the location of major repairs including repaired seams and capped areas. The as-built panel layout must be submitted in hard copy and digital format to the **Owner** and the **Engineer** no later than 30 days after the installation work has been completed.



**Table 1**  
**HDPE Geomembrane - Smooth**  
**(Per GRI Test Method GM13 revision 15 dated 9/9/2019)**

Properties	Test Method	Test Value		Testing Frequency (minimum)
		60 mil (1.5 mm)	80 mil (2 mm)	
Thickness (min. avg.) ▪ Lowest individual of 10 values	ASTM D5199	Nominal -10%	Nominal -10%	Each roll
Density mg/L (min.)	ASTM D1505/D792	0.940 g/cc	0.940 g/cc	200,000 lbs
Tensile Properties <sup>1</sup> (min. avg.) ▪ Yield strength ▪ Break strength ▪ Yield elongation ▪ Break elongation	ASTM D6693 Type IV	126 lbs/in 228 lbs/in 12% 700%	168 lbs/in 304 lbs/in 12% 700%	20,000 lbs
Tear Resistance (min. avg.)	ASTM D1004	42 lbs	56 lbs	45,000 lbs
Puncture Resistance (min. avg.)	ASTM D4833	108 lbs	144 lbs	45,000 lbs
Stress Crack Resistance <sup>2</sup>	ASTM D5397 (Appendix)	500 hrs	500 hrs	Per GRI-GM10
Carbon Black Content (range)	ASTM D4218 <sup>3</sup>	2.0-3.0%	2.0-3.0%	20,000 lbs
Carbon Black Dispersion	ASTM D5596	Note 4	Note 4	45,000 lbs
Oxidative Induction Time (OIT) (min. avg.) <sup>5</sup> a) Standard OIT --OR-- 101 High Pressure OIT	ASTM D3895 ASTM D5885	100 min. 400 min.	100 min. 400 min.	200,000 lbs
Oven Aging at 85°C <sup>5,6</sup> a) Standard OIT (min. avg.) – % retained after 90 days --OR-- b) High Pressure OIT (min. avg.) – % retained after 90 days	ASTM D5721 ASTM D3895 ASTM D5885	55% 80%	55% 80%	Each formulation
UV Resistance <sup>7</sup> Standard OIT (min. avg.) --OR-- High Pressure OIT (min. avg.) - % retained after 1,600 hrs <sup>9</sup>	ASTM D7238 ASTM D3895 ASTM D5885	N.R. <sup>8</sup> 50%	N.R. <sup>8</sup> 50%	Each formulation

<sup>1</sup> Machine direction (MD) and cross machine direction (XMD) average values should be on the basis of 5 test specimens each direction. Yield elongation is calculated using a gage length of 1.3 inches. Break elongation is calculated using a gage length of 2.0 inches.  
<sup>2</sup> The yield stress used to calculate the applied load for the SP-NCTL test should be the manufacturer's mean value via MQC testing.  
<sup>3</sup> Other methods such as D1603 (Tube furnace) or D6370 (TGA) are acceptable if an appropriate correlation to D4218 (muffle furnace) can be established.  
<sup>4</sup> Carbon black dispersion (only near spherical agglomerates) for 10 different views: 9 in Categories 1 or 2 and 1 in Category 3.  
<sup>5</sup> The manufacturer has the option to select either one of the OIT methods listed to evaluate the antioxidant content in the geomembrane.  
<sup>6</sup> It is also recommended to evaluate samples at 30 and 60 days to compare with the 90-day response.  
<sup>7</sup> The condition of the test should be 20 hr. UV cycle at 75°C followed by 4 hr. condensation at 60°C.  
<sup>8</sup> Not recommended since the high temperature of the Std-OIT test produces an unrealistic result for some of the antioxidants in the UV exposed samples.  
<sup>9</sup> UV resistance is based on percent-retained value regardless of the original HP-OIT value.



**Table 2**  
**HDPE Geomembrane - Textured**  
**(Per GRI Test Method GM13 revision 15 dated 9/9/2019)**

Properties	Test Method	Test Value		Testing Frequency (minimum)
		60 mil (1.5 mm)	80 mil (2 mm)	
Thickness (min. avg.) <ul style="list-style-type: none"> <li>▪ Lowest individual of 8 out of 10 values</li> <li>▪ Lowest individual for any of the 10 values</li> </ul>	ASTM D5994	Nominal -5%	Nominal -5%	Each roll
		-10%	-10%	
		-15%	-15%	
Asperity Height mils (min. avg.)	ASTM D7466	16 mil	16 mil	Every 2nd roll <sup>1</sup>
Density mg/L (min. avg.)	ASTM D1505/D792	0.940 g/cc	0.940 g/cc	200,000 lbs
Tensile Properties <sup>2</sup> (min. avg.) <ul style="list-style-type: none"> <li>▪ Yield strength</li> <li>▪ Break strength</li> <li>▪ Yield elongation</li> <li>▪ Break elongation</li> </ul>	ASTM D6693 Type IV	126 lbs/in	168 lbs/in	20,000 lbs
		90 lbs/in	120 lbs/in	
		12%	12%	
		100%	100%	
Tear Resistance (min. avg.)	ASTM D1004	42 lbs	56 lbs	45,000 lbs
Puncture Resistance (min. avg.)	ASTM D4833	90 lbs	120 lbs	45,000 lbs
Stress Crack Resistance <sup>3</sup>	ASTM D5397 (Appendix)	500 hrs	500 hrs	Per GRI-GM10
Carbon Black Content (range)	ASTM D4218 <sup>4</sup>	2.0-3.0%	2.0-3.0%	20,000 lbs
Carbon Black Dispersion	ASTM D5596	Note 5	Note 5	45,000 lbs
Oxidative Induction Time (OIT) (min. avg.) <sup>6</sup>				200,000 lbs
a) Standard OIT	ASTM D3895	100 min.	100 min.	
--OR--				
b) High Pressure OIT	ASTM D5885	400 min.	400 min.	
Oven Aging at 85°C <sup>6,7</sup>	ASTM D5721			
a) Standard OIT (min. avg.) – % retained after 90 days	ASTM D3895	55%	55%	Each formulation
--OR--				
b) High Pressure OIT (min. avg.) – % retained after 90 days	ASTM D5885	80%	80%	
UV Resistance <sup>8</sup>	ASTM D7238			
a) Standard OIT (min. avg.)	ASTM D3895	N.R. <sup>8</sup>	N.R. <sup>8</sup>	Each formulation
--OR--				
b) High Pressure OIT (min. avg.) - % retained after 1,600 hrs <sup>10</sup>	ASTM D5885	50%	50%	

1. Alternate the measurement side for double-sided textured sheet.
2. Machine direction (MD) and cross-machine direction (XMD) average values should be on the basis of five (5) test specimens each direction. Yield elongation is calculated using a gauge length of 1.3 inches. Break elongation is calculated using a gauge length of 2.0 inches.
3. SP-NCTL per ASTM D5397, is not appropriate for testing geomembranes with textured or irregular rough surfaces. Test should be conducted on smooth edges of textured rolls or on smooth sheets made from the same formulation as being used for the textured sheet materials. The yield stress used to calculate the applied load for the SP-NCTL test should be the Manufacturer's mean value via MQC testing.
4. Other methods, such as D1603 (tube furnace) or D6370 (TGA) are acceptable if an appropriate correlation to D4218 (muffle furnace) can be established.
5. Carbon black dispersion (only near spherical agglomerates) for ten (10) different views: Nine (9) in Categories 1 or 2 and one (1) in Category 3
6. The Manufacturer has the option to select either one of the OIT methods listed to evaluate the antioxidant content in the geomembrane.
7. It is also recommended to evaluate samples at 30 and 60 days to compare with the 90-day response.
8. The condition of the test should be 20-hour UV cycle at 75°C followed by 4-hour condensation at 60°C.
9. Not recommended since the high temperature of the Std-OIT test produces an unrealistic result for some of the antioxidants in the UV- exposed samples.
10. UV resistance is based on percent-retained value regardless of the original HP-OIT value.



**Table 3**  
**Seam Strength and Related Properties of Thermally Bonded**  
**Smooth and Textured HDPE Geomembranes**  
 (Reference: GRI Test Method GM19 Revision 9 updated 07/28/2017)

Geomembrane Nominal Thickness	60-mil (1.5 mm)	80-mil (2.0 mm)
<b>Hot Wedge Seams <sup>1</sup></b>		
Shear strength (lbs/in.)	120	160
Shear elongation at break <sup>2</sup> (%)	50	50
Peel strength (lbs/in.)	91	121
Peel separation (%)	≤25	≤25
<b>Extrusion (Fillet) Seams</b>		
Shear strength (lbs/in.)	120	160
Shear elongation at break <sup>2</sup> (%)	50	50
Peel strength (lbs/in.)	78	104
Peel separation (%)	≤25	≤25
<sup>1</sup> Also for hot air and ultrasonic seaming methods.		
<sup>2</sup> Elongation measurements should be omitted for field testing.		

**Table 4: Raw Material Properties**

Property	Test Method	HDPE
Density (g/cm <sup>3</sup> )	ASTM D1505	≥0.932
Melt Flow Index (g/10 min)	ASTM D1238 (190/2.16)	≤1.0
OIT (minutes)	ASTM D3895 (1atm/200°C)	≥100



## **APPENDIX B5 – TECHNICAL SPECIFICATIONS FOR GEOTEXTILE MATERIALS AND CONSTRUCTION**



**CLIENT**  
MAGNUM SOLUTION MINING, LLC

**PROJECT NO**  
475.0093.020

**PROJECT** BRINE POND 4

**TITLE** TECHNICAL SPECIFICATIONS FOR GEOTEXTILE MATERIALS AND CONSTRUCTION

**SPECIFICATION NO.**  
0093.020-SPT-GT-0

REV	DATE	PAGES	APPROVALS			REMARKS
			ORIGINATOR	PM/PIC	CLIENT	
0	9/15/2020	8	JW	KJ	CF	Issued for Construction

**TABLE OF CONTENTS**

1.0 GENERAL ..... 1

    1.1 SCOPE..... 1

    1.2 Definition of Terms ..... 1

    1.3 References ..... 2

        1.3.1 American Society for Testing and Materials (ASTM): ..... 2

        1.3.2 American Association of State Highway and Transportation  
            Officials (AASHTO):..... 2

        1.3.3 Geosynthetic Research Institute (GRI): ..... 2

    1.4 Submittals Post-Award..... 2

    1.5 Submittals during Manufacturing ..... 3

    1.6 Shipment, Storage and Handling..... 3

2.0 PRODUCT ..... 3

    2.1 Geotextile..... 3

3.0 EXECUTION..... 6

    3.1 Quality Assurance ..... 6

    3.2 Installation ..... 7

4.0 CERTIFICATION ..... 8



**CLIENT**  
MAGNUM SOLUTION MINING, LLC

**PROJECT NO**  
475.0093.020

**PROJECT** BRINE POND 4

**TITLE** TECHNICAL SPECIFICATIONS FOR GEOTEXTILE  
MATERIALS AND CONSTRUCTION

**SPECIFICATION NO.**  
0093.020-SPT-GT-0

REV	DATE	PAGES	APPROVALS			REMARKS
			ORIGINATOR	PM/PIC	CLIENT	
0	9/15/2020	8	JW	KJ	CF	Issued for Construction

**TABLE OF CONTENTS**  
**(Continued)**

**LIST OF TABLES**

Table 1 – Required Properties, Test Methods and Values for Geotextiles Used as  
Geomembrane Protection (or Cushioning) Materials ..... 4

Table 2 –Alternative Puncture Test Methods to be Considered in Place of Pin  
Puncture, ASTM D4833 in Table 1..... 4

Table 3 –Geotextile Properties Class 1 (High Survivability) ..... 5

Table 4 –Geotextile Properties Class 2 (Moderate Survivability) ..... 5

Table 5 –Geotextile Properties Class 3 (Low Survivability)..... 5

Table 6 – Required Degree of Survivability as a Function of Subgrade Conditions,  
Construction Equipment and Lift Thickness..... 6





## 1.0 GENERAL

### 1.1 SCOPE

This specification defines the requirements for geotextile materials, installation, and quality control for use as a protection (cushioning) material and as a separation material associated with the Brine Pond 4.

All geotextile for this project shall be 10 oz/yd<sup>2</sup>. Any alternatives or exceptions to this specification shall be submitted in writing to the Owner or its designated representative(s)/agent(s) and shall be approved by the Engineer.

### 1.2 Definition of Terms

- “Owner” is defined as Magnum Solution Mining LLC or any of its authorized representative(s) / agent(s).
- “Engineer” is defined as the Consultant or Engineering Company (NewFields) responsible for the detailed design or any of its authorized representative(s)/ agent(s).
- “Third Party Testing Contractor” is defined as the Consultant or Engineering Company (to be determined) hired by the owner to provide third party inspection and testing services for the overall project.
- “Contractor” is defined as the party(s) that has executed the contract agreement for the specified Work with the Owner or its authorized representative(s)/agent(s).
- “Specifications” are defined as this document, all supplemental addenda, and any modifications furnished by the Owner, the Engineer, or others that apply to the Work.
- “Drawings” are defined as the Construction Drawings for Brine Pond 4 furnished by the Owner, Engineer, or others that apply to the Work.
- “Site” is defined as the Project site near Delta, Utah that is being developed by the Owner and where the Work is to be completed as described in these Technical Specifications and detailed on the Drawings.
- “Contract” is defined as the document executed by the Owner or its authorized representative(s)/agent(s) with the Contractor to complete specified portions of the Work.
- “Work” is defined as the entire completed construction or the various separately identifiable parts thereof required to be furnished as shown on the Drawings and as described in the Specifications and Contract Documents.
- “Modifications” are defined as changes made to the Specifications or the Drawings that are approved by Owner and Engineer in writing, after the Specifications and Drawings have been issued for construction. These also refer to changes to design elements in the field to account for unforeseen conditions.



- “Plant” is defined as all equipment, supplies, accommodations, temporary offices, etc., required to complete the Work.
- “Units” – In general, these Specifications and the Drawings will utilize English units, however metric units will be used when appropriate.

### 1.3 References

#### 1.3.1 American Society for Testing and Materials (ASTM):

- D1883 – Test Method for CBR (California Bearing Ratio) of Laboratory Compacted Soils.
- D4354 – Practice for Sampling of Geosynthetics for Testing
- D4491 – Standard Test Method for Water Permeability of Geotextiles by Permittivity
- D4533 – Test Method for Trapezoidal Tearing Strength of Geotextiles
- D4632 – Test Method for Grab Breaking Load and Elongation of Geotextiles
- D4751 – Standard Test Method for Determining Apparent Opening Size of a Geotextile
- D4759 – Practice for Determining the Specification Conformance of Geosynthetics
- D4833 – Test Method for Index Puncture Resistance of Geotextiles, Geomembranes and Related Products
- D4873 – Guide for Identification, Storage and Handling of Geotextiles
- D5261 – Test Method for Measuring Mass per Unit Area of Geotextiles
- D5494 – Test Method for the Determination of Pyramid Puncture Resistance of Unprotected and Protected Geomembranes
- D6241 – Test Method for Static Puncture Strength of Geotextiles and Geotextile Related Product Using a 50-mm Probe
- D7238 – Test Method for Effect of Exposure of Unreinforced Polyolefin Geomembrane Using Fluorescent Condensation Apparatus

#### 1.3.2 American Association of State Highway and Transportation Officials (AASHTO):

- M288-05 – Geotextile Specification for Highway Applications

#### 1.3.3 Geosynthetic Research Institute (GRI):

- GT12(a) – Test Methods and Properties for Nonwoven Geotextiles Used as Protection (or Cushioning) Materials, Revision 1, December 18, 2012, [www.geosynthetic-institute.org](http://www.geosynthetic-institute.org).
- GT13(a) – Test Methods and Properties for Geotextiles Used as Separation Between Subgrade Soil and Aggregate, Revision 3: December 19, 2012 [www.geosynthetic-institute.org](http://www.geosynthetic-institute.org).

### 1.4 Submittals Post-Award

- Prior to material delivery to the project site, the **Contractor** shall provide the **Engineer** with a written certification or manufacturers quality control data which displays that the geotextile meets or exceeds the values specified herein.



- The **Contractor** shall submit, if required by the **Engineer**, manufacturer's quality control manual for the geotextile to be delivered to the site.

### 1.5 Submittals during Manufacturing

- Manufacturer quality control certificates stating the name of the manufacturer, product name, style number, chemical composition of the filaments or yarns, and other pertinent information to fully describe the geotextile.
- The manufacturer is responsible for establishing and maintaining a quality control program to assure compliance with the requirements of the specification. Documentation describing the quality control program shall be made available upon request.
- The manufacturer's certificate shall state that the finished geotextile meets the Minimum Average Roll Value (MARV) requirements of the specification as evaluated under the manufacturer's quality control program. A person having legal authority to bind the manufacturer shall attest to the certificate.
- Mislabelling or misrepresentation of materials shall be reason to reject those geotextile products.

### 1.6 Shipment, Storage and Handling

- Geotextile labelling, shipment and storage shall follow ASTM D4873. Product labels shall clearly show the manufacturer or supplier name, style, and roll number. Each shipping document shall include a notation certifying that the material is in accordance with the manufacturer's certificate.
- Each geotextile roll shall be wrapped with a material that will protect the geotextile, including the ends of the roll, from damage due to shipment, water, sunlight and contaminants. The protective wrapping shall be maintained during periods of shipment and storage.
- During storage, geotextile rolls shall be elevated off the ground and adequately covered to protect them from the following: site construction damage, precipitation, extended ultraviolet radiation including sunlight, chemicals that are strong acids or strong bases, flames including welding sparks, temperatures in excess of 160°F (71°C), and any other environmental condition that may damage the property values of the geotextile.

## 2.0 PRODUCT

### 2.1 Geotextile

- The nonwoven needle punched geotextile specified herein shall be made from staple fiber.



- The geotextile shall be of new prime quality virgin polymer of 100-percent polyethylene (97-percent polypropylene and 3-percent carbon black with antioxidants and heat stabilizers), or polyester/polypropylene blend designed and manufactured specifically for the purpose of separation, tensile reinforcement, planar flow, filtration and protection and shall be used as designated on the Drawings.
- The geotextile shall be able to withstand direct exposure to ultraviolet radiation from the Sun for up to 30 days without any noticeable effect on index or performance properties.
- Rolls shall be free of holes, contamination and foreign debris.
- Geotextile shall meet or exceed all material properties listed herein based on the specific purpose and expected conditions.

**Table 1 – Required Properties, Test Methods and Values for Geotextiles Used as Geomembrane Protection (or Cushioning) Materials**

Property <sup>1</sup>	Test Method ASTM	Unit	Mass/Unit Area (oz/yd <sup>2</sup> )					
			10	12	16	24	32	60
Mass per unit area	D5261	oz/yd <sup>2</sup>	10	12	16	24	32	60
Grab Tensile strength	D4632	lb	230	300	370	450	500	630
Grab tensile elongation	D4632	%	50	50	50	50	50	50
Trap. Tear strength	D4533	lb	95	115	145	200	215	290
Puncture (pin) strength	D4833	lb	120	140	170	250	300	390
UV resistance <sup>2</sup>	D7238	%	70	70	70	70	70	70

**Table 2 – Alternative Puncture Test Methods to be Considered in Place of Pin Puncture, ASTM D4833, in Table 1**

Property <sup>1</sup>	Test Method ASTM	Unit	Mass/Unit Area (oz/yd <sup>2</sup> )					
			10	12	16	24	32	60
Mass per unit area	D5261	oz/yd <sup>2</sup>	10	12	16	24	32	60
Puncture (pyramid) strength	D5494	lb	300	320	410	440	510	760
Puncture (CBR) strength	D6241	lb	700	800	900	1100	1700	2400
Puncture (CBR) elongation	D6241	in	1.5	1.5	1.5	1.5	1.5	1.5

Notes:

1. All values are MARV except UV resistance which is a minimum value. For geosynthetics, MARV is a manufacturing quality control tool used to establish published values such that the purchaser will have a 97.7% confidence that the property in question will meet published values. For normally distributed data, "MARV" is calculated as the typical value minus two (2) standard deviations from documented quality control test results for a defined population from one specific test method associated with one specific property.
2. Evaluation to be on 2.0 inch strip tensile specimens after 500 lt. hours exposure.



- For the purposes of separation the geotextile shall meet the minimum required values as defined in the Tables 3, 4 and 5 below with the exception of AOS which is maximum average roll value (MaxARV) and UV stability which is a minimum average value:

**Table 3– Geotextile Properties Class 1 (High Survivability)**

Property <sup>1</sup>	ASTM Test	Unit	Elongation < 50%	Elongation ≥ 50%
Grab Tensile Strength	D4632	lb	315	203
Trapezoid Tear Strength	D4533	lb	112	79
CBR Puncture Strength	D6241	lb	630	440
Permittivity	D4491	sec <sup>-1</sup>	0.02	0.02
Apparent Opening Size	D4751	in	0.024	0.024
UV Stability <sup>2</sup>	D7238	% Str. Ret. @ 500 lt. hours	50	50

**Table 4 – Geotextile Properties Class 2 (Moderate Survivability)**

Property <sup>1</sup>	ASTM Test	Unit	Elongation < 50%	Elongation ≥ 50%
Grab Tensile Strength	D4632	lb	248	158
Trapezoid Tear Strength	D4533	lb	90	56
CBR Puncture Strength	D6241	lb	500	320
Permittivity	D4491	sec <sup>-1</sup>	0.02	0.02
Apparent Opening Size	D4751	in	0.024	0.024
UV Stability <sup>2</sup>	D7238	% Str. Ret. @ 500 lt. hours	50	50

**Table 5– Geotextile Properties Class 3 (Low Survivability)**

Property <sup>1</sup>	ASTM Test	Unit	Elongation < 50%	Elongation ≥ 50%
Grab Tensile Strength	D4632	lb	180	113
Trapezoid Tear Strength	D4533	lb	68	41
CBR Puncture Strength	D6241	lb	380	230
Permittivity	D4491	sec <sup>-1</sup>	0.02	0.02
Apparent Opening Size	D4751	in	0.024	0.024
UV Stability <sup>2</sup>	D7238	% Str. Ret. @ 500 lt. hours	50	50



**Table 6 – Required Degree of Survivability as a Function of Subgrade Conditions, Construction Equipment and Lift Thickness (Class 1, 2 and 3 Properties are Given in Table 3, 4 and 5; Class 1+ Properties are Higher than Class 1 but Not Defined at this Time)**

	Low ground-pressure equipment $\leq 25$ kPa (3.6 psi)	Medium ground-pressure equipment $> 25$ to $\leq 50$ kPa ( $> 3.6$ to $\leq 7.3$ psi)	High ground-pressure equipment $> 50$ kPa ( $> 7.3$ psi)
Subgrade has been cleared of all obstacles except grass, weeds, leaves and fine wood debris. Surface is smooth and level so that any shallow depressions and humps do not exceed 450 mm (18 in.) in depth or height. All larger depressions are filled. Alternatively, a smooth working table may be placed.	Low (Class 3)	Moderate (Class 2)	High (Class 1)
Subgrade has been cleared of obstacles larger than small to moderate-sized tree limbs and rocks. Tree trunks and stumps should be removed or covered with a partial working table. Depressions and humps should not exceed 450mm (18 in.) in depth or height. Larger depressions should be filled.	Moderate (Class 2)	High (Class 1)	Very High (Class 1+)
Minimal site preparation is required. Trees may be felled, delimbed, and left in place. Stumps should be cut to project not more than $\pm 150$ mm (6 in.) above subgrade. Fabric may be draped directly over the tree trunks, stumps, large depressions and humps, holes, stream channels, and large boulders. Items should be removed only if placing the fabric and cover material over them will distort the finished road surface.	High (Class 1)	Very High (Class 1+)	Not Recommended

\*Recommendations are for 150 to 300 mm (6 to 12 in.) initial lift thickness. For other initial lift thicknesses:

- 300 to 450mm (12 to 18 in.): reduce survivability requirement one level;
- 450 to 600mm (18 to 24 in.): reduce survivability requirement two levels;
- >600mm (24 in.): reduce survivability requirement three levels;

Note 1: While separation occurs in every geotextile application, this pavement-related specification focuses on subgrade soils being “firm” as indicated by CBR values higher than 3.0 (soaked) or 8.0 (unsoaked).

Source: Modified after Christopher, Holtz and DiMaggio

### 3.0 EXECUTION

#### 3.1 Quality Assurance

- A. The **Engineer** or **Third Party Testing Contractor** shall examine the geotextile rolls upon delivery to the site and report any deviations from project specifications to the contractor.
- B. The **Engineer** may decide to arrange conformance testing of the rolls delivered to the job site. For this purpose, the **Engineer** shall take a sample three feet (along roll length)



by roll width according to ASTM Practice D 4354 The sample shall be properly marked, wrapped and sent to an independent laboratory for conformance testing.

- C. The pass or fail of the conformance test results shall be determined according to ASTM Practice D 4759.

### 3.2 Installation

- A. The geotextile shall be handled in such a manner as to ensure that it is not damaged in any way. Should the **Contractor** damage the geotextile to the extent that it is no longer usable as determined by these specifications or by the **Engineer** or **Third Party Testing Contractor**, the **Contractor** shall replace the geotextile at his own cost.
- B. The geotextile shall be installed to the lines and grades as shown on the contract drawings and as described herein.
- C. The geotextile shall be rolled down the slope in such a manner as to continuously keep the geotextile in tension by self-weight. The geotextile shall be securely anchored in an anchor trench where applicable, or by other approved or specified methods.
- D. In the presence of wind, all geotextiles shall be weighted by sandbags or approved equivalent. Such anchors shall be installed during placement and shall remain in place until replaced with cover material.
- E. The **Contractor** shall take necessary precautions to prevent damage to adjacent or underlying materials during placement of the geotextile. Should damage to such material occur due to the fault of the **Contractor**, the latter shall repair the damaged materials at his own cost and to the satisfaction of the **Engineer**.
- F. During placement of the geotextile, care shall be taken not to entrap soil, stones or excessive moisture that could hamper subsequent seaming of the geotextile as judged by the **Engineer** or **Third Party Testing Contractor**.
- G. The geotextile shall not be exposed to precipitation prior to being installed and shall not be exposed to direct Sun light for more than 15 days after installation.
- H. The geotextile shall be seamed using heat seaming or stitching methods as recommended by the manufacturer and approved by the **Engineer**. Sewn seams shall be made using polymeric thread with chemical resistance equal to or exceeding that of the geotextile. All sewn seams shall be continuous. Seams shall be oriented down slopes perpendicular to grading contours unless otherwise specified. For heat seaming, fusion welding techniques recommended by the manufacturer shall be used.
- I. The contractor shall not use heavy equipment to traffic above the geotextile without approved protection.
- J. The geotextile shall be covered as soon as possible after installation and approval. Installed geotextile shall not be left exposed for more than 15 days.
- K. Material overlying the geotextile shall be carefully placed to avoid wrinkling or damage to the geotextile.
- L. Holes in the geotextile material shall be repaired using a patch of identical material extending a minimum 6 inches on all sides of the hole and heat bonded. If heat bonding is not possible, the patch shall extend a minimum of 18 inches on all sides of the hole.



M. In areas where the non-woven geotextile is used as separation or filtration, care shall be taken to install the layer without producing holes or gaps where the migration of fines into the drainage system could occur. This is accomplished by ensuring sufficient overlap of seams of 18-inches minimum overlap and properly wrapping the edges of the geotextile under the gravel areas being protected or by over running the edges of the geotextile beyond the area requiring separation or filtration.

#### **4.0 CERTIFICATION**

At the completion of the geotextile installation, the **Contractor** shall provide the **Owner** with a certification stating that the geotextile was installed and tested in accordance with the Specifications together with a report of the test results. The certification shall be provided to the **Owner** prior to the demobilization of the installation personnel from the site unless agreed otherwise by the **Owner**. The report of the test results shall be provided in hard copy and digital format to the **Owner** and the **Engineer** no later than 30 days after the installation work has been completed.





**APPENDIX B6 – TECHNICAL SPECIFICATIONS FOR GEONET MATERIALS  
AND CONSTRUCTION**



**CLIENT**  
MAGNUM SOLUTION MINING, LLC

**PROJECT NO**  
475.0093.020

**PROJECT** BRINE POND 4

**TITLE** TECHNICAL SPECIFICATIONS FOR GEONET AND  
INSTALLATION

**SPECIFICATION NO.**  
0093.020-SPT-GN-0

REV	DATE	PAGES	APPROVALS			REMARKS
			ORIGINATOR	PM/PIC	CLIENT	
0	9/15/2020	6	JW	KJ	CF	Issued for Construction

**TABLE OF CONTENTS**

1.0 GENERAL ..... 1

    1.1 SCOPE..... 1

    1.2 Definition of Terms ..... 1

    1.3 References ..... 2

        1.3.1 American Society for Testing and Materials (ASTM): ..... 2

        1.3.2 Environmental Protection Agency (EPA): ..... 2

        1.3.3 Geosynthetic Research Institute (GRI): ..... 2

    1.4 Submittals Post-Award..... 2

    1.5 Submittals during Manufacturing ..... 3

    1.6 Shipment, Storage and Handling..... 3

    1.7 Warranty ..... 3

2.0 PRODUCT ..... 4

    2.1 Geonet Properties..... 4

3.0 EXECUTION..... 4

    3.1 Quality Assurance ..... 4

    3.2 Installation ..... 4

    3.3 Seams and Overlaps..... 5

    3.4 Repairs ..... 5

4.0 CERTIFICATION ..... 6

**LIST OF TABLES**

Table 1 – Required Properties, Test Methods and Values for Geonet ..... 4



## 1.0 GENERAL

### 1.1 SCOPE

This specification defines the requirements for the manufacturing and installation of the geonet drainage layer for the Magnum Solution Mining LLC (Owner), Brine Pond 4.

The geonet for this project shall have a thickness of 200 mils as defined in Table 1. Any alternatives or exceptions to this specification shall be submitted in writing to the Owner or its designated representative(s)/agent(s) and shall be approved by the Engineer.

### 1.2 Definition of Terms

- “Owner” is defined as Magnum Solution Mining LLC or any of its authorized representative(s) / agent(s).
- “Engineer” is defined as the Consultant or Engineering Company (NewFields) responsible for the detailed design or any of its authorized representative(s)/ agent(s).
- “Contractor” is defined as the party(s) that has executed the contract agreement for the specified Work with the Owner or its authorized representative(s)/agent(s).
- “Specifications” are defined as this document, all supplemental addenda, and any modifications furnished by the Owner, the Engineer, or others that apply to the Work.
- “Drawings” are defined as the Construction Drawings for Brine Pond 4 furnished by the Owner, Engineer, or others that apply to the Work.
- “Site” is defined as the Magnum Project site near Delta, Utah that is being developed by the Owner and where the Work is to be completed as described in these Technical Specifications and detailed on the Drawings.
- “Contract” is defined as the document executed by the Owner or its authorized representative(s)/agent(s) with the Contractor to complete specified portions of the Work.
- “Work” is defined as the entire completed construction or the various separately identifiable parts thereof required to be furnished as shown on the Drawings and as described in the Specifications and Contract Documents.
- “Modifications” are defined as changes made to the Specifications or the Drawings that are approved by Owner and Engineer in writing, after the Specifications and Drawings have been issued for construction. These also refer to changes to design elements in the field to account for unforeseen conditions.



- “Plant” is defined as all equipment, supplies, accommodations, temporary offices, etc., required to complete the Work.
- “Units” – In general, these Specifications and the Drawings will utilize English units, however metric units will be used when appropriate.

### 1.3 References

#### 1.3.1 American Society for Testing and Materials (ASTM):

- D1238 – Standard Test Method for Melt Flow Rates of Thermoplastics by Extrusion Plastometer.
- D1505 – Standard Test Method for Density of Plastics by the Density - Gradient Technique.
- D1603 – Standard Test Method for Carbon Black in Olefin Plastics.
- D4716 – Standard Test Method for Determining the (In-Plane) Flow Rate Per Unit Width and Hydraulic Transmissivity of a Geosynthetic Using a Constant Head.
- D5035 – Standard Test Method for Breaking Force and Elongation of Textile Fabrics (Strip Method).
- D5199 – Standard Test Method for Measuring Nominal Thickness of Geotextiles and Geomembranes.

#### 1.3.2 Environmental Protection Agency (EPA):

- Daniel, D.E. and R.M. Koerner, (1993), Technical Guidance Document: Quality Assurance and Quality Control for Waste Containment Facilities, EPA/600/R-93/182.

#### 1.3.3 Geosynthetic Research Institute (GRI):

- GN-2 and GC-13 – Standard Guide for Joining and Attaching Geonets and Drainage Composites, September 25, 2012, [www.geosynthetic-institute.org](http://www.geosynthetic-institute.org).

### 1.4 Submittals Post-Award

- Prior to material delivery to the project site, the **Contractor** shall provide the **Engineer** with a written certification or manufacturers quality control data which displays that the geonet meets or exceeds the values specified herein.
- The **Contractor** shall submit, if required by the **Engineer**, manufacturer’s quality control manual for the geonet to be delivered to the site.



### 1.5 Submittals during Manufacturing

- Manufacturer quality control certificates stating the name of the manufacturer, product name, length, width, roll number and any other pertinent information to fully describe the geonet.
- The manufacturer is responsible for establishing and maintaining a quality control program to assure compliance with the requirements of the specification. Documentation describing the quality control program shall be made available upon request.
- The manufacturer's certificate shall state that the finished geonet meets the Minimum Average Roll Value (MARV) requirements of the specification as evaluated under the manufacturer's quality control program. A person having legal authority to bind the manufacturer shall attest to the certificate.
- Mislabelling or misrepresentation of materials shall be reason to reject those geonet products.

### 1.6 Shipment, Storage and Handling

- Product labels shall clearly show the manufacturer or supplier name, style, and roll number. Each shipping document shall include a notation certifying that the material is in accordance with the manufacturer's certificate.
- Delivery of rolls of geonet will be prepared to ship by appropriate means to prevent damage to the material and to facilitate off-loading.
- The on-site storage location for the geonet shall be provided by the **Contractor** and shall protect the geonet from abrasions, excessive dirt and moisture. The area shall be level (no wooden pallets), smooth, protected from vandalism and close to the area being lined.
- The **Contractor** and **Installer** shall handle all geonet in such a manner as to ensure it is not damaged in any way.
- The **Installer** shall take all necessary precautions to prevent damage to the underlying layers during placement of the geonet.

### 1.7 Warranty

- The material shall be warranted, on a prorated basis against defects for a period of 1-year from the date of the geonet installation.
- Installation shall be warranted against defects in workmanship for a period of 1-year from the date of geonet completion.



## 2.0 PRODUCT

### 2.1 Geonet Properties

The geonet shall be manufactured by extruding two crossing strands to form a bi-planar drainage net structure.

The geonet specified shall have the properties that meet or exceed the values listed in Table 1 below.

**Table 1 – Required Properties, Test Methods and Values for Geonet**

Property	Test Method ASTM	Frequency (Minimum)	Units	Values			
Thickness, nominal	D5199	1/ 50,000 ft <sup>2</sup>	mils (mm)	200 (5.0)	250 (6.3)	275 (7.0)	300 (7.6)
Density (minimum)	D1505/ D792, Method B	1/ 50,000 ft <sup>2</sup>	g/cm <sup>3</sup>	0.94	0.94	0.94	0.94
Tensile Strength (Machine Direction)	D5035	1/ 50,000 ft <sup>2</sup>	lbs./in. (N/mm)	45 (7.9)	55 (9.6)	65 (11.5)	75 (13.3)
Carbon Black Content	D4218/D1603 <sup>2</sup>	1/ 50,000 ft <sup>2</sup>	%	2-3	2-3	2-3	2-3
Melt Flow Index	D1238, 190°, 2.16kg	Per Resin Lot	g/10 minutes (max.)	≤1.0	≤1.0	≤1.0	≤1.0
Transmissivity <sup>1</sup>	D4716	1/ 500,000 ft <sup>2</sup>	m <sup>2</sup> /sec	2x10 <sup>-3</sup>	3x10 <sup>-3</sup>	6x10 <sup>-3</sup>	8x10 <sup>-3</sup>

Notes: <sup>1</sup> Gradient of 0.1, normal load of 10,000psf (479 kN/m<sup>2</sup>), water at 70°F (21°C), between steel plates for 15 minutes.

<sup>2</sup> Modified.

## 3.0 EXECUTION

### 3.1 Quality Assurance

- The **Engineer** shall examine the geonet rolls upon delivery to the site and report any deviations from project specifications to the **Contractor**.
- The **Engineer** may decide to arrange conformance testing of the rolls delivered to the job site. For this purpose, the **Engineer** shall take a sample three feet (along roll length) by roll width according to ASTM Practice D 4354. The sample shall be properly marked, wrapped and sent to an independent laboratory for conformance testing.
- The pass or fail of the conformance test results shall be determined according to ASTM Practice D 4759.

### 3.2 Installation

- The geonet roll should be installed in the direction of the slope and in the intended direction of flow unless otherwise specified by the **Engineer**. At no time shall any vehicles (pickup trucks, cars, Gator Utility Vehicles (or similar), Four Wheeler ATV's (or



similar) be driven on the geonet. If so, the **Engineer** shall be informed and inspect the area for damage or require replacement or repairs.

- If the project contains long, steep slopes, special care should be taken so that only full-length rolls are used at the top of the slope.
- In the presence of wind, all geonet shall be weighted down with sandbags or the equivalent. Such sandbags shall be used during placement and remain until replaced with cover material.
- If the project includes an anchor trench at the top of the slopes, the geonet shall be properly anchored to resist sliding. Anchor trench compacting equipment shall not come into direct contact with the geonet.
- In applying fill material, no equipment can drive directly across the geonet. The specified fill material shall be placed and spread utilizing vehicles with a low ground pressure.
- The top geomembrane shall be placed in the geonet in a manner that prevents damage to the geonet. Placement of the top geomembrane shall proceed immediately following the placement and inspection of the geonet.

### 3.3 Seams and Overlaps

- Each component of the geonet will be secured to the like component at overlaps.
- Geonet Components
  - Adjacent edges along the length of the geonet roll shall be overlapped a minimum of 4" or as recommended by the **Engineer**.
  - The overlapped edges shall be joined by tying the geonet structure with cable ties. These ties shall be spaced every 5 feet along the roll length. Ties for connecting the seams shall be resistant to degradation due to ultraviolet light and should be compatible with the process solution for which it could be exposed. Ties should be installed such that the clasp of the tie is placed between the grids of the geonet.
  - Adjoining rolls across the roll width should be shingled down in the direction of the slope a minimum of 1-foot overlap and joined together with cable ties spaced every foot along the roll width.

### 3.4 Repairs

- Prior to covering the deployed geonet, each roll shall be inspected by the **Installer** and the **Engineer** for damage resulting from construction.
- Any rips, tears or damaged areas on the deployed geonet greater than 2 inches shall be patched. The patch shall extend 6 inches beyond the damage and shall be secured to the original geonet by tying every 6 inches with the approved tying devices. If the area to be repaired is more than 50 percent of the width of the panel, the damaged area shall be cut out and the two portions of the geonet shall be joined in accordance with Subsection 3.3.



#### 4.0 CERTIFICATION

At the completion of the geonet installation, the **Installer** shall provide the **Owner** with a certification stating that the geonet was installed and tested in accordance with these specifications together with a report of the test results. The certification shall be provided to the **Owner** prior to the demobilization of the installation personnel from the site unless agreed otherwise by the **Owner**. The report of the test results shall be provided in hard copy and digital format to the **Owner** and the **Engineer** no later than 30 days after the installation work has been completed.





**MAGNUM**



**CONSTRUCTION QUALITY CONTROL  
CONSTRUCTION QUALITY ASSURANCE  
(CQC/CQA) PLAN**

**FOR CONSTRUCTION  
OF BRINE PONDS**

HAL Project No.: 345.03.102

February 2013

**MAGNUM**  
**CONSTRUCTION QUALITY CONTROL /**  
**CONSTRUCTION QUALITY ASSURANCE (CQC/CQA) PLAN**  
**FOR CONSTRUCTION**  
**OF BRINE PONDS**



**Project Engineer**

Prepared by:

Hansen, Allen & Luce, INC.  
Consulting Engineers  
6771 South 900 East  
Midvale, Utah 84047

**February 2013**

## TABLE OF CONTENTS

	Page
I. INTRODUCTION .....	1
II. ORGANIZATION, RESPONSIBILITY, AND AUTHORITY .....	2
Organization and Authority .....	2
Responsibilities .....	3
Project Manager.....	3
CQA Officer .....	4
Design Engineer .....	5
Earthwork Contractor.....	5
Construction Quality Assurance (CQA) Personnel .....	5
Geosynthetics Installer Contractor .....	6
Independent Geosynthetics Testing Laboratory .....	7
Soils Testing Laboratory .....	7
Independent Survey.....	8
III. PROJECT MEETINGS .....	9
Pre-construction CQA Meeting .....	9
Weekly Construction/CQA Meetings.....	9
IV. INSPECTION ACTIVITIES .....	11
V. MINOR DESIGN CHANGE PROCEDURES.....	12
VI. DOCUMENTATION.....	13

### TABLES

After Page

Table 1 – Brine Pond Construction Inspection Activities.....	14
--	----

### FIGURES

Figure 1 - CQA Program Organization Structure .....	3
---	---

### APPENDICES

Appendix A – Testing Frequency Tables

Appendix B - Non-Destructive Seam Testing Procedures

## I. INTRODUCTION

Magnum NGLs, L.L.C. (Magnum) has developed this Construction Quality Control / Construction Quality Assurance (CQC/CQA) Plan to ensure that its NGLs project with its accompanying brine ponds complies with the applicable EPA and Utah Department of Water Quality (UDWQ) regulations and demonstrates that the regulatory requirements for the construction impoundment structures, including the inspection of liners, will be met. The plan is intended as a reference for both construction and regulatory personnel. The plan first discusses the project organization, responsibilities, and authority of the various personnel involved. It describes the qualifications of personnel involved in the administration and implementation of the CQA Plan. The inspection activities associated with the project are defined. It discusses meetings that should be held during the project. Finally, the plan details the documentation required to provide evidence of adherence to this plan.

The professional work and good judgment of each contractor and each employee, supplemented by strong management commitment and resources, is essential to maintaining the expected quality of construction. This CQC/CQA Plan is accepted by management of Magnum as their standard for brine pond construction. All employees shall adhere to its provisions and are encouraged to report all issues of non-conformance or of conditions affecting quality.

The process of continuous quality improvement leads to the development of a better and more responsive CQC/CQA Plan. Lessons learned from each aspect of construction, operation, and technological evaluations and updates should be used to augment or enhance Magnum's CQC/CQAS Plan. Contractors and consultants are empowered to perform to the best of their abilities and are encouraged to identify opportunities for improvement, problems, and to offer solutions to problems. Magnum management seeks continuous quality improvement and encourages and supports meeting or exceeding the expectations of customers and regulatory agencies whenever possible.

## **II. ORGANIZATION, RESPONSIBILITY, AND AUTHORITY**

Magnum NGLs, L.L.C. (Magnum) will be the operator of the brine ponds at their facility. As such, it recognizes that it is ultimately responsible for the design, construction, and operation of the facilities at the site. Magnum recognizes that it is responsible for complying with the requirements of the permitting agency in these activities, including providing high quality CQC/CQA that provides the proper documentation that the facility was constructed as specified in the CQC/CQA Plan. Magnum has the authority and responsibility to determine what individuals or organizations will be responsible for the design, CQA, and construction activities. Magnum also has the authority and responsibility for determining the organizational structure for these activities.

### **Organization and Authority**

Magnum has assigned the above indicated responsibilities of overseeing all activities associated with the design and construction of their brine ponds, with specific emphasis to the CQA program, to the Project Manager. The organizational structure for the CQA program is illustrated in Figure 1. As illustrated in Figure 1, the Project Manager is ultimately responsible for all activities associated with the successful construction of the brine ponds. The construction quality assurance has been organized so that all individuals involved in construction will ultimately report to the CQA Officer, who will report to the Project Manager.

The implementation of the CQA Plan occurs through the CQA Officer. The Construction Quality Control (CQC) personnel will function independently of the CQA personnel and will be responsible for ensuring that the work items associated with the ponds are constructed in accordance with the plans and the specifications defined herein. CQC personnel will be responsible for conducting the various tests and observations within their assigned areas as specified in the CQA Plan, for documenting those tests, and for reporting and reviewing the test results with the CQA personnel.

CQA personnel will ensure that all observation and testing activities required to ensure compliance with the plans and the specifications are being carried out by CQC personnel. CQA personnel will ensure that the designated frequency of testing is being accomplished and that all aspects of the CQA Plan are being carried out. The primary responsibility of the CQA personnel will be to review the documentation prepared and/or obtained by the CQC personnel, as defined herein. The review of documentation by the CQA personnel will also include field observation of activities associated with the CQA Plan at the frequencies specified herein to ensure that the CQA Plan is being executed properly.

### **Responsibilities**

The specific responsibilities of the various individuals or entities presented in the organizational chart of Figure 1 are presented on the following page.

**FIGURE 1  
CQA PROGRAM ORGANIZATIONAL STRUCTURE**

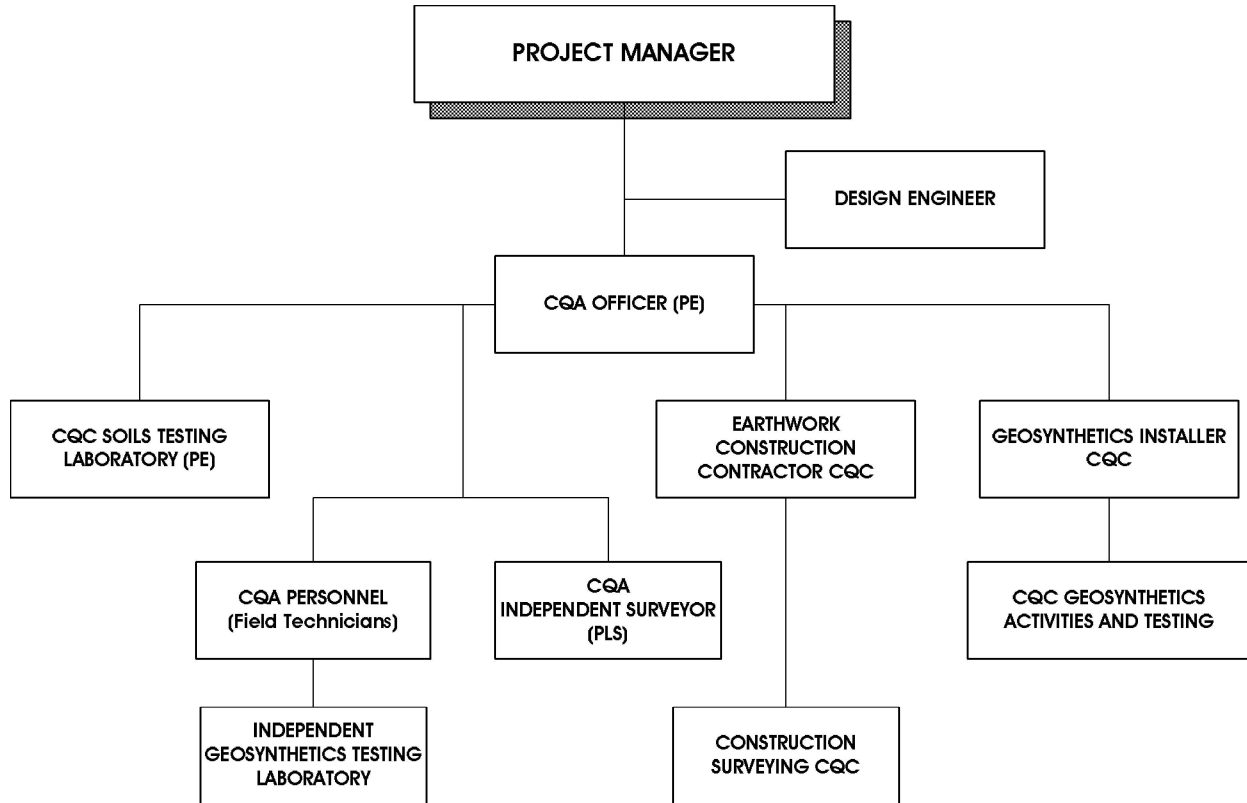

## Project Manager

As indicated, the Project Manager has the responsibility for overseeing all aspects associated with the design and construction of the brine ponds at the Western Energy Hub. The Project Manager assumes the responsibilities of the facility owner.

The specific responsibilities of the Project Manager include:

1. Ultimately responsible for successful design and construction of the brine ponds and for selecting and dismissing organizations or individuals charged with design, construction, CQC and CQA activities.
2. Oversee CQC and CQA activities.

## **CQA Officer**

The Project Manager assigns the CQA Officer the specific responsibility of overseeing the construction quality assurance aspects of the project. The CQA Officer coordinates aspects of the CQA Plan with the Project Manager. In the absence of the CQA Officer from the work site, the duties and responsibilities of the CQA Officer shall be delegated to one of the CQA personnel. The CQA Officer shall have the following qualifications:

- Licensed Professional Engineer in the State of Utah
- 10 years of experience.
- Two years of similar project construction observation and management experience.

The specific responsibilities of the CQA Officer include:

1. Report directly to the Project Manager.
2. Interaction with CQC Personnel.
3. Review soils and geosynthetic materials testing documentation completeness.
4. Review of Surveying documentation.
5. Periodic site visits during the brine pond construction.
6. Responsible for activities of CQA personnel. CQA personnel will not be on-site during the earthwork construction other than periodic site visits by the CQA Officer. CQA personnel will be on-site during geosynthetics installation.
7. Verify that the CQC personnel are completing and properly documenting all on-site observations and tests required to ensure compliance with the CQA Plan. This is accomplished by verifying that CQA personnel are reviewing and approving, on a daily basis, the results of on-site observations and testing completed by the CQC personnel and that CQA personnel are satisfied that testing and observations are in accordance with the CQA Plan.
8. Review, coordinate, and approve CQA activities to ensure that testing and documentation are complete and accurate (as specified in Table 1 and Appendix A)
9. Oversee preparation of the final construction report at the completion of the project, which will be a compilation of all of the daily reports generated during the course of construction, as well as a summary report of all CQC and CQA activities.

## **Design Engineer**

The responsibilities of the Design Engineer include those design activities which occur during the construction of the project. The specific responsibilities include the following:

1. Review and approve minor design changes to the brine ponds to meet the operational requirements of the owner and the permitting requirements of the agencies.
2. Coordinate design changes with the CQA Officer.
3. Approve corrective measures to be implemented where deviation occurs during construction from the design.

The Design Engineer has authority to work within the framework of the design and CQA Plan. The Design Engineer does not have the authority to make any decisions that would alter the design and the CQA Plan for the facility without the express approval of the CQA Officer (refer to Section V – Minor Design Change Procedures) and the regulatory agency (UDWQ and UDWRi), where applicable.

## **Earthwork Contractor**

The Earthwork Contractor will have the following qualifications:

- Licensed as a General Contractor in the State of Utah.

Specific responsibilities of the Earthwork Contractor with regard to CQC are as follows:

1. Facilitate CQC activities associated with earthwork construction.
2. Report to the Project Manager.
3. Ensure that all construction activities performed by the Earthwork Contractor and all Sub-contractors is in accordance with the project specifications and the CQA/CQC Plan.
4. Facilitate all testing required to ensure compliance with project specifications.
5. Provide for grade control and construction surveying beyond site survey controls provided.
6. Ensure that all regulatory requirements associated with construction activities and the construction contract are met.



7. Obtain all required environmental and safety permits required by regulations (including but not limited to dust control, storm water pollution prevention, health and safety, etc.)

### **Construction Quality Assurance (CQA) Personnel**

The Construction Quality Assurance (CQA) personnel will work under the direction of the CQA Officer to ensure that the CQA Plan is executed properly. The CQA personnel will ensure that all observation and testing activities required to ensure compliance with the CQA Plan are being carried out by the CQC personnel. The authority of the CQA personnel will be limited to the performance of observation and documentation requirements of the CQA Plan. The CQA personnel will not have the authority to modify in any way the design or requirements of the CQA Plan. The CQA personnel will have authority to stop work as per the directive of the CQA Officer. Specific responsibilities of the CQA personnel include the following:

1. Conduct all reviews and observations defined in the CQA Plan that have been established as measures to determine the effectiveness of all testing, observations, and controls conducted or established to ensure a quality outcome for the construction of the cells and closure caps. This includes daily reviews of the results of all testing and observations conducted by CQC personnel as defined herein. It includes additional observations required to be conducted by CQA personnel directly to ensure compliance of the CQC personnel with testing and observation requirements.
2. Verify that the equipment used in testing has been calibrated.
3. Ensure that all required testing is conducted in accordance with the CQA Plan.
4. Report to the CQC personnel immediately the results of observations and tests that fail to meet the CQA Plan.
5. Verify that corrective action has been taken (where required) and recorded on the daily construction reports.
6. Prepare and assemble the required documentation of the results of on-site observations, testing, and reviews conducted by CQC and CQA personnel.
7. Provide the results of on-site observations, testing, and documentation of the work in progress to the CQA Officer.

### **Geosynthetics Installer Contractor**

The Earthwork Contractor will have the qualifications set forth in the CQA/CQC Plan (Table 1).

The geosynthetics installer will provide CQC according to the following:

Magnum

February 2013

1. Perform all CQC activities defined in this CQA/CQC Plan for geosynthetics installation.
2. Report to the Project Manager and interaction with the CQA Officer and CQA personnel.
3. Provide all submittals regarding qualifications, personnel, materials, etc. required by the specifications and this CQA/CQC Plan to the CQA Officer.
4. Provide all documentation and required testing associated with installation of geosynthetic materials as defined in this CQA/CQC Plan. Document the results of all required testing and submit the documentation to the CQA Officer.

### **Independent Geosynthetics Testing Laboratory (CQA)**

The independent geosynthetics testing laboratory will provide CQA according to the following:

1. Perform all CQA activities defined in this CQA/CQC Plan for independent geosynthetics testing.
2. Report to the CQA Officer and Project Manager.
3. Provide testing of geosynthetic materials required of the independent geosynthetics testing laboratory as defined in this CQA/CQC Plan. Document the results of all required testing and submit the documentation to the CQA Officer.

### **Soils Testing Laboratory (CQC)**

The soils testing laboratory will provide CQC and will have the following qualifications:

- Necessary equipment and personnel to conduct required testing.
- Licensed Professional Engineer in the State of Utah in charge of all testing activities.

The soils testing laboratory will provide CQC testing according to the following:

1. Report to the Project Manager and interaction with the CQA Officer for field CQC testing of soils.
2. Provide all documentation and required testing associated with soils placement as defined in this CQA/CQC Plan and in the specifications. Document the results of all required testing and submit the documentation to the CQA Officer.
3. Prepare and submit a report to the CQA Officer certifying the results of all materials testing performed by the Soils Testing Laboratory. Provide a Professional

Engineer seal on the certification report by the Professional Engineer responsible for soils testing activities certification report.

### **Independent Survey (CQA)**

The surveyor will provide CQA and will have the following qualifications:

- Necessary equipment and personnel to conduct required survey.
- Registered Land Surveyor in the State of Utah.

The surveyor will provide CQA survey according to the following:

1. Report to the Project Manager and the CQA Officer.
2. Provide surveying if requested by the CQA Officer to document grade controls and grading tolerances from design lines and grades.
3. Provide certification of all survey documentation.

### III. PROJECT MEETINGS

Meetings should be held during the project to enhance communications between personnel responsible for design, inspection, and construction of the project. These meetings will include a pre-construction CQA meeting and weekly construction/CQA meetings.

#### **Pre-Construction CQA Meeting**

Pre-construction CQA meetings should be held prior to the commencement of soils-related construction activities and geosynthetics-related installation activities for the project. Those to attend should include the Project Manager, CQA Officer, CQC and CQA personnel, and the earthwork construction contractor and liner installation contractor, as appropriate. Copies of the CQA Plan should be distributed to the above indicated parties prior to the pre-construction CQA meeting. Minutes of the meeting should be prepared and transmitted to all personnel in attendance. The CQA Officer should notify the UDWQ and UDWRi of the proposed pre-construction meeting date. Items to be discussed in this meeting should include, but not be limited to:

1. Familiarizing each organization with the CQA Plan and their role relative to the CQA Plan.
2. Reviewing the responsibilities, lines of authority, and communication of each organization.
3. Discussing the procedures for observations and testing (as specified in Table 1 and Appendix A).
4. Discussing procedures for handling construction deficiencies, repairs, and retesting.
5. Reviewing methods for reporting and documenting testing and inspection activities.
6. Reviewing methods for distributing and storing documents and reports.
7. Identifying work areas and equipment and materials storage areas.
8. Identifying required submittals for the project.
9. Discussing procedures employed by soils contractor and/or geosynthetics installer to train operators and/or technicians to provide a quality work product.

#### **Weekly Construction/CQA Meetings**

Meetings should be held approximately once per week to discuss the progress of the project during both earthwork construction and liner installation. Those to attend should include the CQA Officer, a representative of the CQC personnel, a representative of the CQA personnel, and a representative of the contractor (as needed). When earthwork and liner installation are

happening at the site simultaneously then the weekly meeting will combine CQA and construction update discussions for both earthwork and liner installation. Additional meetings can be called by the CQA Officer to address critical problems. Items to be discussed in this meeting should include, but not be limited to:

1. Discussing the CQC, CQA, and construction activities and accomplishments of the previous week.
2. Exchanging, reviewing, and discussing required documentation of construction, observation, and testing activities.
3. Defining and discussing problems or deficiencies associated with the work and CQC and CQA activities. Documenting problems or deficiencies discussed in the CQC file.
4. Reviewing alternative solutions.
5. Implementing corrective actions to resolve problems or deficiencies.

CQA personnel should prepare minutes of the meeting for distribution to all attending parties.

#### **IV. INSPECTION ACTIVITIES**

This section of the CQA Plan describes the inspection activities (observations and tests) that will be performed by the CQC and CQA personnel during the construction and installation of the work elements associated with the project.

Table 1 provides the specific requirements of the CQC/CQA Plan for the pond construction for both the earthwork and the liner installation and includes the major work elements that comprise the project; the specifications governing each work element; the CQC activities to be performed in a timely manner to ensure a quality outcome of each work element; and the CQA activities to be performed in a timely manner to determine and ensure the effectiveness of the CQC activities. Table 1 identifies the observations and tests to be conducted by the CQC and CQA personnel, the frequency of observations and tests, the acceptance/rejection criteria that will be used in the evaluation of the tests, and how the observations and tests are to be recorded and documented. Table 1 may also refer to tests and frequencies located in the technical specifications for the project.

Measuring and testing equipment (M&T) used for critical items of construction must be controlled in order to ensure the quality outcome of the project. M&T equipment used for critical items of construction include the nuclear gage, scales, sealed single ring infiltrometer used by the CQC personnel associated with the testing of the soils related aspects of the project, surveying equipment used by the surveyor in checking and controlling construction grades, pressure gages used in the non-destructive testing of the HDPE liner welds and tensiometers, for peel and shear tests of HDPE welds. The M&T equipment is provided to the project by the firm that provides the CQC services. This equipment is to be calibrated annually at a minimum. At the beginning of the project, the CQC firm will provide the CQA personnel with documentation confirming that the equipment has been calibrated. This documentation will be included in the construction documentation report at the completion of construction of the project.

## **V. MINOR DESIGN CHANGE PROCEDURES FOR EITHER EARTHWORK OR LINER**

This section describes the procedure for initiating and approving minor changes in a timely manner necessary to maintain or enhance quality during construction. As the need for minor changes occurs, they must be controlled by both Magnum and by the regulatory agency. A minor change can be defined as changes that do not decrease the environmental protection or stability of the unit (minor changes will not include decreasing the number or thickness of liners, changing lining requirements, providing steeper sideslopes, etc.).

Mutual agreement between the regulatory authority and Magnum as to the proposed change will normally occur prior to submission of supporting documentation to the regulatory agency for processing. The following procedures will be applicable:

1. The need for a design change, engineering, or construction changes may become apparent during the course of construction of the project and a request for a change may be initiated by any individual associated with the project.
2. All proposed design engineering and construction changes will be reviewed and approved by the Design Engineer and the Project Manager. If approved, the Project Manager will provide documentation to the CQA Officer indicating that the proposed change(s) will meet the minimum quality requirements of the project.
3. The Project Manager will review and approve or disapprove the proposed change(s) based on the documentation and recommendation of the Design Engineer.
4. If the Project Manager approves the proposed change(s), verbal notification of the proposal should be made to the Utah Department of Water Quality (UDWQ) and Utah Division of Water Rights (UDWRi). The scope of the proposal will be discussed to obtain a mutual understanding and agreement as to the proper type of change action.
5. All documentation submitted to the agencies regarding change(s) will be included in the construction documentation report. Record Drawing details of the project will be prepared that will reflect approved changes.

## VI. DOCUMENTATION

Documentation of construction and inspection activities associated with the CQA Plan will consist of daily recordkeeping and a final report to be prepared under the direction of the CQA Officer. Daily reporting procedures associated with the CQC and CQA activities are described based on specific work elements in Table 1 of the CQC and CQA activities section and are to be performed in a timely manner.

The results of testing and observations as recorded on the daily construction reports will be reviewed and accepted by the CQA Officer or his designee. Acceptance of the daily construction reports will consist of either counter-signing the forms directly or having one of the CQA personnel sign the forms indicating that they have been reviewed and accepted on behalf of the CQA Officer. During the construction of the facility, the CQA Officer will be responsible for maintaining and storing the originals or copies of all data sheets and reports that are generated in carrying out the CQA Plan as identified herein. The Project Manager will review and approve of the construction reports and documentation at appropriate intervals as the project progresses.

Results of all material tests and daily inspection reports will be submitted to the UDWRi on a weekly basis during the construction phase.

The CQA Officer will direct the preparation of a final construction documentation report at the completion of the project. This report will contain all of the documentation associated with the daily reporting procedures, as well as the following summary reports:

1. CQA Report
2. Soils Report – Completed by CQC Soils Testing Laboratory
3. Synthetic Liner Report – Completed by the Geosynthetics Installer Contractor
4. "Record" Drawings

The CQA report will provide a summary of CQA activities and will demonstrate that the construction satisfied the CQA Plan and applicable State and Federal regulations. The CQA report will provide an evaluation of the degree of reconciliation between non-conforming work and the specifications as defined in the CQA Plan and the ability of the CQA program to meet the quality objectives of the CQA Plan.

The Soils Report will provide a summary of the soils observation and testing aspects of the construction or closure project. The report will certify that the soils portions of the pond were constructed in accordance with the CQA Plan and any field design, engineering, or construction changes made in accordance with the minor change procedures.

The Synthetic Liner Report will include a summary of the synthetic liner observation and testing aspects of the project. The report will certify that the synthetic liner portions of the pond are constructed in accordance with the CQA Plan and any field design, engineering, or construction changes made in accordance with the minor change procedures. The Synthetic Liner Report will be certified by the geosynthetics installer.



The Final Report will be reviewed and approved by the Project Manager and will be submitted to the UDWQ and UDWRi following the completion of the project. The CQA Officer must certify that the CQA Plan has been successfully carried out.

TABLE 1 – BRINE POND CONSTRUCTION INSPECTION ACTIVITIES

EARTHWORKS		
SPECIFICATION	QUALITY CONTROL	QUALITY ASSURANCE
	Review geotechnical investigation report to become familiar with the expected site conditions.	Review geotechnical investigation report to become familiar with the expected site conditions.
<p><b>CLEARING &amp; STRIPPING:</b> Remove all organic and objectionable materials to the limits shown on the Drawings or as required by the Engineer. Stripping is defined as the removal of topsoil, which shall be defined as soil of any gradation or degree of plasticity that contains significant quantities of visually identifiable plant matter, sod, roots, or humus as determined by the engineer.</p> <p>Prior to any surface treatment on a stripped area notify CQC so that inspection of area may be completed.</p>	<p>Observe and document the clearing and stripping operation. Ensure soft and yielding spots are corrected by drying and recompacting the material or are removed and disposed of as directed by the CQA Officer. Ensure material so removed is replaced with a suitable material and is compacted to the density requirements. Provide daily observation until task is completed. Record observations and corrective actions taken on "Daily Construction Reports". Provide CQA personnel with copies of "Daily Construction Reports" and obtain their signature on reports indicating acceptance. Ensure that corrective actions required by CQA personnel are accomplished.</p>	<p>Observe area when task is complete. Review daily reports generated by CQC personnel. Report deficiencies to CQC personnel and the CQA Officer and record communications. Verify that corrective action has been taken (where required) and recorded on CQC "Daily Construction Reports". Record findings of observations, review, and actions taken.</p>
<p><b>GRADING/EMBANKMENT FOUNDATION PREPARATION:</b> Grade all work areas according to the limits shown on the drawings and as described in the technical specifications. All standards laid out in technical specifications are to be met.</p> <p>Areas of unsuitable material shall be excavated to the limits designated by CQC and replaced with compacted random fill.</p> <p>No fill material shall be placed on the foundation without prior approval of the State Engineer. Arrangements to place such fill shall be made with the State Engineer's personnel sufficiently in advance to avoid construction delays.</p> <p>Any conditions that differ appreciably from those assumed during design must be reported to the State Engineer before work continues.</p>	<p>Ensure sub-grade is prepared according to technical specifications.</p> <p>Conduct in-place moisture and density tests. Testing is to be conducted at the frequency and using applicable methods as indicated in technical specifications. The location of the tests shall be chosen on a random basis.</p> <ol style="list-style-type: none"> <li>1. Approve areas with tests indicating a density <math>\geq</math> 95.0%</li> <li>2. Approve areas with moisture contents from minus (-) 2.0% to plus (+) 2.0%.</li> <li>3. Identify each area that does not meet compaction criteria and verify the area is brought into compliance via the contractor reworking the area.</li> <li>4. Retest areas reworked and approve areas meeting criteria of "1" above.</li> <li>5. Continue reworking and retesting until the area meets criteria of "1" above.</li> <li>6. Record all results and corrective actions taken on "Daily Construction Reports".</li> <li>7. Provide CQA personnel with copies of the "Daily Construction Reports" and obtain their signature on Reports indicating acceptance.</li> <li>8. Ensure that corrective actions required by CQA personnel are accomplished.</li> </ol> <p>Ensure that areas of unsuitable material as defined in technical specification are removed.</p>	<p>Review density test results recorded on "Daily Construction Reports".</p> <ol style="list-style-type: none"> <li>1. Verify frequency of tests.</li> <li>2. Verify that compaction in areas accepted is at least 95.0%.</li> <li>3. Verify that the moisture content in areas accepted is within the range of minus (-) 2.0% to plus (+) 2.0% of the optimum moisture content.</li> </ol> <p>Report deficiencies to CQC personnel and the CQA Officer and record communications. Verify that corrective action has been taken (where required) and recorded on CQC "Daily Construction Reports". Record findings of observations, review, and actions taken.</p> <p>Send the results of all material tests and daily inspection reports to the UDWRi on a weekly basis and to UDWQ as requested.</p>

TABLE 1 – BRINE POND CONSTRUCTION INSPECTION ACTIVITIES

EARTHWORKS		
SPECIFICATION	QUALITY CONTROL	QUALITY ASSURANCE
<p><b>EXCAVATIONS AND BORROWS:</b> Remove vegetation, debris, organic, or deleterious material from excavation and borrow areas and other activities as stated in technical specifications.</p> <p>If historical resources such as human remains (skeletons), prehistoric arrowheads/spear points, waste flakes from stone tool production, pottery, ancient fire pits, historical building foundations/remains, artifacts (glass, ceramic, metal, etc.) are found, call the Utah Division of State History at (801) 533-3555.</p>	<p>Observe excavation and borrow areas once they have been cleared and grubbed. Record observations and corrective actions taken on "Daily Construction Reports". Provide CQA personnel copies of "Daily Construction Reports" and obtain their signature on reports indicating acceptance. Ensure that corrective actions required by CQA personnel are accomplished.</p> <p>Observe that no historical resources are found.</p>	<p>Observe excavation and borrow areas when task is complete. Review daily reports generated by CQC personnel. Report deficiencies to CQC personnel and the CQA Officer and record communications. Verify that corrective action has been taken (where required) and recorded on CQC "Daily Construction Reports." Record findings of observations, review, and actions taken.</p>
<p><b>EMBANKMENT AND BACKFILL:</b> Embankment and backfill material will be placed with heavy construction equipment and will be compacted to at least 95% of the Standard Proctor density as determined by ASTM D-698 with a moisture content of minus (-) 2.0% to plus (+) 2.0% of the optimum moisture content. Material compacted with hand operated tampers will be compacted to 95% of the maximum dry density as determined by ASTM-D-698 with a moisture content of minus (-) 2.0% to plus (+) 2.0% of the optimum moisture content.</p>	<p>Conduct in-place moisture and density tests. Testing is to be conducted using applicable methods and at a frequency indicated in the technical specifications. The location of the test site shall be chosen on a random basis.</p> <ol style="list-style-type: none"> <li>Approve areas with tests indicating a density <math>\geq</math> 95.0%. Approve areas with moisture content from minus (-) 2.0% to plus (+) 2.0% of the optimum moisture content.</li> <li>Identify each area that does not meet compaction criteria and verify that the area is brought into compliance via the contractor reworking the area or by removing and replacing the material.</li> <li>Retest areas reworked or for which material was removed and replaced, and approve areas meeting criteria of "1" above.</li> <li>Continue "2" and "3" until the area meets criteria of "1" above.</li> <li>Record all results and corrective actions taken on "Daily Construction Reports".</li> <li>Provide CQA personnel with copies of the "Daily Construction Reports" and obtain their signature on reports indicating acceptance.</li> <li>Ensure that corrective actions required by CQA personnel are accomplished.</li> </ol>	<p>Review density test results recorded on the "Daily Construction Reports".</p> <ol style="list-style-type: none"> <li>Verify frequency of tests.</li> <li>Verify that compaction in areas accepted is <math>\geq</math> 95.0%. Verify that the moisture content in areas accepted is (-) 2.0% to plus (+) 2.0% of the optimum moisture content.</li> </ol> <p>Report deficiencies (if any) to CQC personnel and the CQA Officer and record communications. Verify that corrective action has been taken (where required) and recorded on CQC "Daily Observation and Testing" reports. Record findings of observations, review, and actions taken.</p> <p>Send the results of all material tests and daily inspection reports to the UDWRI on a weekly basis and to UDWQ as requested.</p>
<p><b>PLACEMENT:</b> Backfill and fill shall be placed in uniform lifts. A lift is defined as 8 inches or less in loose depth for material compacted by heavy compaction equipment, and 4 inches or less in loose depth for material compacted by hand-operated tampers. In anchor trenches, the first lift shall be placed not more than 12 inches in loose depth with subsequent lifts placed 4 inches in loose depth. Where backfill is placed around pipes, the first lift will be</p>	<p>Observe material as it is placed. Record observations and corrective actions taken in "Daily Construction Reports" throughout fill placement. Provide CQA personnel with copies of the "Daily Construction Reports" and obtain their signature on reports indicating acceptance. Ensure that corrective actions required by CQA personnel are accomplished.</p>	<p>Review daily reports generated by CQC personnel. Report deficiencies (if any) to CQC personnel and the CQA Officer and record communications. Verify that corrective action has been taken (where required) and recorded on CQC "Daily Construction Reports." Record findings of observations, review, and actions taken.</p>

TABLE 1 – BRINE POND CONSTRUCTION INSPECTION ACTIVITIES

EARTHWORKS		
SPECIFICATION	QUALITY CONTROL	QUALITY ASSURANCE
<p>placed to a depth slightly higher than the spring-line of the pipe, to prevent displacement of the pipe.</p> <p>If the ambient air temperature is less than 32 degrees Fahrenheit for more than 2 hours over the preceding 24 hours the temperature of any fill materials being placed must be measured to determine if fill is frozen. The contractor may either remove and replace frozen fill or wait until subsequent temperature monitoring indicates the fill is unfrozen, prior to placing additional materials.</p>	<p>Ensure fill is not frozen by measuring the temperature of in-place fill according to technical specifications. Construction may not continue without corrective action. Record observations and corrective actions taken in "Daily Construction Reports." Provide CQA personnel with copies of the "Daily Construction Reports" and obtain their signature on reports indicating acceptance. Ensure that corrective actions required by CQA personnel are accomplished.</p>	
<p><b>GRADING:</b> In-place embankment materials and natural soils shall be fine graded to the designed elevation and typical sections. Acceptable grading tolerance limits for finished embankment surfaces shall be as follows:</p> <ol style="list-style-type: none"> <li>1. Finish grades and slopes for the embankment and basin shall be in general conformance with the Drawings. Deviations from finished grades/slopes are subject to approval by CQC and shall not result in low spots; pockets; non-uniform slopes or contours; or result in slopes which deviate by more than 1% from the design; or result in slopes of less than 0.5% within the basin.</li> <li>2. The maximum permissible combined horizontal and vertical deviation of the perimeter boundaries of the embankment from the lines and grades shown on the Drawings or as required by CQC shall be 36 inches.</li> <li>3. The finished surface of the basin prepared surface shall not deviate vertically by more than 4 inches than the lines and grades shown on the drawings.</li> <li>4. The elevation and width of the embankment crest shall not be less than the dimensions shown on the Drawings or required by CQC.</li> </ol>	<p>Review certified record survey for compliance to CQA Plan. Document results in "Daily Construction Report".</p>	<p>Ensure a licensed surveyor conducts survey at completion. Survey points will be on at least a 50 foot grid and at all control points. Surveyor shall indicate where the embankment meets the design line and grade. Deficiencies shall be reported to the CQC personnel. Once corrective action has been taken the deficient area will be re-surveyed to verify line and grade. Final survey measurement will be documented, certified, and provided to the design engineer and the CQA Officer.</p> <p>Review final survey data. Verify the frequency of survey measuring points. Verify that the surveyor certified that the construction is to the specified line and grade. Report deficiencies (if any) to CQC personnel and the CQA Officer and record communications. Record findings of observations, review, and actions taken.</p>
<p><b>ANCHOR TRENCH:</b> The anchor trenches shall be completed in accordance with the drawings. Smooth out or cushion rough areas of the trench prior to placement of the geomembrane in the trench. The geomembrane shall be seamed or welded through the bottom of the anchor trench. Acceptable backfill shall be select native clay and</p>	<p>Periodically inspect backfill materials, welding of geomembrane in anchor trench, &amp; lift thickness. Test primary anchor trench backfill for density and moisture content at a rate of one test per 200 feet of trench per lift of backfill.</p>	<p>Observe and document that welding of geomembrane materials in the anchor trench is completed as specified.</p>

TABLE 1 – BRINE POND CONSTRUCTION INSPECTION ACTIVITIES

EARTHWORKS		
SPECIFICATION	QUALITY CONTROL	QUALITY ASSURANCE
silt materials and shall not consist of sand or other coarse grained materials. The backfill shall be placed in an initial twelve inch loose lift. Subsequent lifts shall be six loose inches. The backfill will be placed and compacted to $\geq$ 95% of the maximum dry density by ASTM D-698		

**\*SUPERSEDED\***

**\*Appendix B – Technical Specifications (NewFields, 2021) Supersedes this page**

TABLE 1 – BRINE POND CONSTRUCTION INSPECTION ACTIVITIES

GEOMEMBRANE LINERS		
SPECIFICATION	QUALITY CONTROL	QUALITY ASSURANCE
<p><b>REQUIREMENTS PRIOR TO LINER PLACEMENT:</b> Prior to geomembrane installation, the liner manufacturer and installer contractor shall provide the CQA and CQC personnel:</p> <ol style="list-style-type: none"> <li>Quality Control Certificates: Each roll of liner must have a unique identification number, an indication of thickness, length, width, and manufacturer's name. A QC certificate must be provided for every 25,000 square feet of material manufactured consecutively. A certificate will be provided for each roll that was not produced consecutively. If liner certificates indicate material does not meet the specifications defined in the Technical Specifications, the material is to be marked conspicuously and removed from the construction area.</li> <li>Polymer Raw Material Certificates: The liner manufacturer is to supply certification that the resin meets the density specification defined in the Technical Specifications and that it is all from the same manufacturer.</li> <li>Welding Rod Certification: The welding rod manufacturer is to provide certification that the rod is of the same polymer as the sheet and from the same manufacturer.</li> <li>Résumé of Installation Supervisor: Installation supervisor is to have prior experience supervising installation of a minimum of ten (10) million square feet of liner.</li> <li>Installer's Quality Control Manual.</li> </ol>	<p>Review installer's Quality Control Manual to ensure adherence to the stricter of the guidelines between the installer's manual and the Engineers Technical Specifications.</p> <p>Review required submittals for compliance with specifications. Rolls of liner not meeting specifications are to be marked conspicuously and moved to a location designated by the CQA personnel. Rolls of liner shall not be deployed until approval has been received from the CQA personnel indicating that the rolls meet specifications.</p> <p>Submit a copy of the installer's Quality Control Manual to the Engineer and to CQA personnel.</p>	<p>Review installer's Quality Control Manual to ensure adherence to the stricter of the guidelines between the installer's manual and the Engineers Technical Specifications. The Lead technician over CQA personnel shall have a minimum of 10,000,000 square feet of geosynthetics CQA experience.</p> <p>Receive, review, and approve required submittals prior to allowing liner to be deployed in landfill. Review the results of the required submittals with the CQA Officer.</p> <ol style="list-style-type: none"> <li>Document roll numbers and quality control certificates received. Note any rolls not meeting specifications and document that roll was removed from the construction area.</li> <li>Document the polymer raw material certificates received and the package number of the polymer raw material certificates with corresponding roll numbers to which it pertains.</li> <li>Ensure that the welding rod certification is received and included in the documentation record.</li> <li>Provide documentation to CQC personnel noting which rolls of liner were approved and installation supervisors and master welders that have been approved.</li> </ol>
<p><b>GEOMEMBRANE LINER SUBSURFACE PREPARATION:</b> The surfaces on which the HDPE liner is to be placed is to be free of sharp particles, rocks, or other debris that might damage the overlying geosynthetics. Sharp objects shall be removed by raking, sweeping or handpicking as necessary. No standing water shall be allowed.</p>	<p>Activities identifying the requirements for surveying to check grades of the surfaces are identified under the earthwork section of this table. In addition to these requirements, CQC personnel and the liner contractor are to observe the surface which will form the subgrade. The contractor is to certify in writing that the surface on which the HDPE liner is to be installed is acceptable.</p>	<p>Activities regarding grading are identified under the earthwork section of this table.</p> <p>Observe the subgrade for the HDPE liners with the CQC personnel and the liner contractor. Report deficiencies (if any) to CQC personnel and the CQA Officer and record communications. Verify that corrective action has been taken (where required) and recorded on CQC "Daily Construction Reports." Countersign "Daily Construction</p>

TABLE 1 – BRINE POND CONSTRUCTION INSPECTION ACTIVITIES

GEOMEMBRANE LINERS		
SPECIFICATION	QUALITY CONTROL	QUALITY ASSURANCE
	Record observations and corrective actions taken on the "Daily Construction Reports." Provide CQA personnel with copies of the "Daily Construction Reports" and obtain their signature on reports indicating acceptance. Verify that corrective actions required by CQA personnel are accomplished.	Reports indicating documentation is adequate, correct, and has been accepted by CQA. Record findings of observations, reviews, and action taken.
<p><b>HANDLING OF GEOMEMBRANE LINER:</b> HDPE liner shall be labeled with manufacturer, thickness, and roll number prior to shipment to the site. When transported to the site, the HDPE liner shall be handled by appropriate means so that no damage is caused to the liner. Transportation to the site shall be the responsibility of the installer.</p> <p>On-site unloading, storage, and handling are the responsibilities of the installer. Liner materials shall be stored in a location away from possible sources of deterioration. Appropriate handling equipment shall be used to move HDPE liner. The liner shall not be dragged on the ground. Persons walking or working on the geomembrane shall not engage in activities or wear shoes that could damage the geomembrane liner.</p>	Review HDPE liner rolls to ensure that they are labeled according to the specifications. Ensure HDPE liner is handled according to specifications.	Note any rolls not labeled properly and have them removed from the construction area. Observe and document that the HDPE rolls are handled according to the specifications.
<p><b>GEOMEMBRANE LINER PLACEMENT:</b> Prior to installation, the liner contractor shall present to the CQA Officer a liner placement plan. The plan shall indicate the panel configuration and location of seams. Seams shall be oriented parallel to the line of the maximum slope. Seams placed in high stress areas will be minimized (i.e., cell corners, parallel with the top of the embankment, or at the toe of the side slopes). No seams shall be placed parallel to and within 10 feet of the toe of the slope.</p> <p>The installer shall take into account that frequent high winds may result in delays. The installer shall take all necessary measures to ensure that each panel is sufficiently ballasted to prevent damage or movement by wind. The panels shall be secured temporarily with sandbags or other approved ballasting method to hold them in place until the field seams have been completed and the geomembrane liner has been permanently anchored.</p> <p>Fusion of panels and repairs will only be permitted under weather conditions allowing work that is in conformance to</p>	Review liner placement plan and submit plan to the CQA officer for approval.	<p>The CQA Officer is to review the liner placement plan and approve or disapprove the plan. The CQA Officer is to review and approve any modifications to the proposed layout plan during construction.</p> <p>Observe panel deployment and verify that the placement specification items have been met. Review the panel deployment forms for accuracy and completeness. Report deficiencies (if any) to CQC personnel and the CQA Officer and record communications. Verify that corrective action has been taken (where required) and recorded on the form. Record findings of review and actions taken. Countersign form indicating acceptance of documentation and accuracy and completeness of data. Include copy of executed form in CQA documents.</p>

TABLE 1 – BRINE POND CONSTRUCTION INSPECTION ACTIVITIES

GEOMEMBRANE LINERS		
SPECIFICATION	QUALITY CONTROL	QUALITY ASSURANCE
<p>the specifications and within the warranty limits imposed by the manufacturer and to the approval of the Engineer.</p> <p>The liner is to be placed as closely as practical to the layout plan. The installer shall give each field panel an identification code number consistent with the layout plan. The record drawing will be updated to reflect any modifications to the layout plan. Care shall be exercised to not damage the HDPE liner during installation.</p> <p>Rolls are to be inspected as they are unwound for equipment damage, holes, blisters, thin spots, undispersed raw materials, or any signs of contamination by foreign material. Note: In several instances, visual defects (such as blisters) are small enough that the repair of a visual defect may consist of placing a bead of extrudate from the extrusion welding gun over the visual defect. Welding beads placed to repair such visual defects are not considered extrusion welding and therefore do not require vacuum testing. Any form of hole or penetration through the liner must be patched with a liner cap which must be vacuum tested.</p>	<p>Observe that the liner is placed in accordance with the approved layout plan. Advise the CQA Officer of contractor-proposed modifications. Maintain a record drawing showing the placement of the panels. Document the deployment of the panels on the appropriate form.</p> <p>Observe the liner as the rolls are unwound for holes, blisters, thin spots, undispersed raw materials, or any signs of contamination by foreign material. Mark roll number conspicuously on the panel and then more closely inspect the panel for defects. Mark defective areas found for repair or removal. Document that defective areas were repaired.</p>	<p>Observe that the liner is placed in accordance with the approved layout plan. Maintain a record drawing showing the placement of the panels.</p> <p>Observe the liner as the rolls are unwound for holes, blisters, thin spots, undispersed raw materials, or any signs of contamination by foreign material. Mark roll number conspicuously on the panel and then more closely inspect the panel for defects. Mark defective areas found for repair or removal. Document that defective areas were repaired.</p>
<p><b>WELDING:</b> The double-wedge fusion welding process shall be used unless alternate methods are approved by the Engineer. Extrusion welding will be permitted to weld short seams, to repair small areas, where double-wedge welding is not feasible, and where test samples have been removed.</p> <p>No welding equipment or operator shall perform production welds until equipment and operator have successfully completed a trial weld. Trial welds shall be completed under the same surface and environmental conditions as the production welds. A minimum of two trial welds per day per welding apparatus shall be completed – one prior to the start of work and one at mid-shift or for every 5 hours of seaming operations. Five 1-inch-wide-by-6-inch-long test strips will be cut from the trial weld and will be tested for peel adhesion and for bonded seam strength. Trial weld specimens shall pass when the results shown in Table 4 of the Geomembrane technical specifications in both peel and shear tests and the break, when peel testing, occurs by Separation in the Plane of the sheet (SIP), not through adhesion failure separation (AD) and the break is ductile. The trial weld is to be repeated in its entirety when the trial weld samples fail in either peel or</p>	<p>Document the type of weld, the date welded, and the welding technician for each seam on the appropriate form.</p> <p>Observe pre-weld testing and record results on the appropriate form. Ensure that problems are corrected and actions taken to correct problems are recorded.</p>	<p>Review results recorded on CQC and CQA forms for accuracy and completeness.</p> <p>Observe pre-weld testing. Review results recorded on CQC forms for accuracy and completeness. Report deficiencies (if any) to CQC personnel and the CQA Officer and record communications. Verify that corrective action has been taken (where required) and recorded on the above form. Record findings of review and actions taken. Countersign forms indicating acceptance of documentation and accuracy and completeness of data. Include copy of executed forms in CQA documentation.</p>

**\*Appendix B – Technical Specifications (NewFields, 2021) Supersedes this page**



TABLE 1 – BRINE POND CONSTRUCTION INSPECTION ACTIVITIES

GEOMEMBRANE LINERS		
SPECIFICATION	QUALITY CONTROL	QUALITY ASSURANCE
<p>shear as defined on Table 4, footnote 2 of the Geomembrane technical specifications. After any second pre-weld test failure, two consecutive pre-weld samples must be made, tested, and have passing results before that particular technician/equipment combination is put into production welding.</p> <p>Seams shall be cleaned of dust, mud, moisture, and debris immediately ahead of welding apparatus and shall be aligned consistent with the requirements of the welding equipment being used. Overlap shall be 4 to 6-inches for double wedge welded seams and 6-inches for extrusion welded seams unless approved otherwise by the Engineer. No overlaps shall be placed parallel to and within 10 feet of the toe of the embankment. Seams must be aligned with the fewest amount of wrinkles or fishmouths.</p>	<p>Observe seams prior to welding to ensure compliance with the specifications.</p>	<p>Review results recorded on CQC and CQA forms for accuracy and completeness.</p>
<p><b>NON-DESTRUCTIVE SEAM TESTING:</b> All production welding using the Fusion Weld method will be tested using the "Seam Air Pressure Test", while seams using the extrusion process will be tested by vacuum testing or electrostatic spark testing. Procedures for the non-destructive testing as well as procedures for repairing or patching the seams in the event of failure are presented in the technical specifications.</p>	<p>Perform non-destructive testing of welds. Record and document the results of the non-destructive seam testing on the appropriate form. Mark each panel with initials and date inspected at the end of each panel. Mark any area showing a defect and repaired in accordance with the applicable repair procedures.</p>	<p>Observe the testing performed by the CQC personnel on the seam welds. Where defective results are obtained, require and verify that the seams are repaired in accordance with the requirements presented in the technical specifications. Review daily the forms prepared by CQC personnel.</p>
<p><b>DESTRUCTIVE SEAM TESTING:</b> Seams of the installed geomembrane shall be destructively tested including patches and repair areas in accordance with technical specifications. Destructive testing is to be accomplished by cutting a sample of a seam for the purpose of verifying conditions through field and laboratory testing. One sample of destructive testing will be cut from seams at least every 500 linear feet or part of 500 feet if the part is <math>\geq</math> 50 feet. The sample shall be taken by cutting perpendicular to the seams a sample approximately 36 by 12 inches. These samples shall be tested on site for peel and shear seams strength and thickness in accordance with D6392. 20% of these samples shall also be sent to an independent third party laboratory to be tested. The third party laboratory shall perform the tests required in the technical specifications.</p>	<p>Obtain samples for destructive testing at the intervals indicated. Pass/fail criteria will be according to GRI GM-19. Number each sample obtained and document the seam number associated with the sample, the seam length, the sample number, the sample location, etc. on the appropriate forms. Record sampling locations on the liner placement plan. Divide the sample into three approximately 12 inch x 12 inch samples, one of which is to be tested in the peel and shear modes. The other samples are to be divided between CQA personnel and the owner of the facility.</p>	<p>Accompany CQC personnel and designate sampling locations in accordance with required frequency. Review the forms prepared by the CQC personnel to ensure that sample numbers with corresponding information have been properly recorded. Verify that indicated locations for samples on the form correspond with locations in the field by observation and measurement. Resolve any discrepancies with CQC personnel. Archive samples (approximately 12 inches x 12 inches or portions thereof) as directed by the CQA Officer. The CQA Officer shall send 20% of destructive samples to third party laboratory for testing and review results to confirm independent testing meets specifications and confirm passing/failing results to CQC personnel.</p>
<p><b>ANCHOR TRENCH:</b> The anchor trenches shall be completed in accordance with the drawings. Smooth out or cushion rough areas of the trench prior to placement of</p>	<p>Periodically inspect backfill materials, welding of geomembrane in anchor trench, &amp; lift thickness. Test primary anchor trench backfill for density and moisture</p>	<p>Observe and document that welding of geomembrane materials in the anchor trench is completed as specified.</p>

TABLE 1 – BRINE POND CONSTRUCTION INSPECTION ACTIVITIES

GEOMEMBRANE LINERS		
SPECIFICATION	QUALITY CONTROL	QUALITY ASSURANCE
the geomembrane in the trench. The geomembrane shall be seamed or welded through the bottom of the anchor trench. Acceptable backfill shall be select native clay and silt materials and shall not consist of sand or other coarse grained materials. The backfill shall be placed in an initial twelve inch loose lift. Subsequent lifts shall be six loose inches. The backfill will be placed and compacted to ≥ 95% of the maximum dry density by ASTM D-698	content at a rate of one test per 200 feet of trench per lift of backfill.	
<b>REPAIR PROCEDURES:</b> Damaged or defective geomembrane or seam areas failing a destructive or non-destructive test shall be repaired. The Installer shall be responsible for repair of damaged or defective areas. The repair method shall be decided by the installer but shall be decided agreed upon by the Engineer.	<p>Perform non-destructive testing on the seams of all patches and caps. Where defective results are obtained, require, verify, and document that seams are repaired. Record and document observations on the appropriate form.</p> <p>Perform field peel and shear testing on coupons taken from the samples as indicated above. Record the results of the peel and shear testing on the appropriate form. If a sample fails the destructive testing, then the following shall be done:</p> <ol style="list-style-type: none"> <li>Two coupons shall be taken from the same seam approximately 10 feet from each side of the original sample. The coupons are to be tested for peel &amp; shear.</li> <li>If any one of the coupons fails to meet the passing criteria, more coupons will be taken at a distance away from the failure at the discretion of the CQA personnel. The coupons are to be tested for peel &amp; shear.</li> <li>Item b. is to be repeated until it is determined that the extent of the defective seam has been defined.</li> <li>When the extent of the defective seam has been defined, a regular 36" x 12" sample will be taken at the perceived end of the defect for testing.</li> <li>Each sample hole and coupon hole shall be individually patched, then the entire length of the defective seam, including the patches, shall be capped; or each sample hole and coupon hole shall be individually patched, then the entire length of</li> </ol>	<p>Inspect, on a daily basis when the activity is occurring, patches and caps prior to welding to ensure that seams are clean, dry, and have adequate overlap, as per the specifications. Observe seams for excessive grinding. Observe the non-destructive testing performed by CQC personnel. Where defective results are obtained, require and verify that seams are repaired. Review daily the forms prepared by CQC personnel.</p> <p>Observe, on a daily basis when the activity is occurring, the peel and shear testing conducted by the CQC personnel. Determine, based on the pass/fail criteria, whether or not the peel and shear tests have passed or failed. Review daily the form prepared by CQC personnel to ensure that the results are immediately recorded and are recorded accurately. Obtain copies of the report for the CQA file.</p> <p>Ensure destructive testing is completed in accordance with the criteria set forth under the CQC column in the event that destructive testing indicates a failure. Designate required additional sampling locations to CQC personnel. Review daily destructive seam testing forms prepared by CQC personnel to ensure that sample numbers with corresponding information have been properly recorded. Verify that the indicated locations for samples on the form correspond with locations in the field by observation and measurement. Resolve any discrepancies with the CQC personnel. Once each page of the above indicated form is complete and the CQA personnel have reviewed and accepted the results indicated on the form, the CQA personnel shall approve data thereon. A copy of the forms are then retained for CQA documentation. Compare peel and shear testing results with the acceptance-rejection criteria to ensure that welds meet the criteria. Review the above indicated forms to ensure that the results have</p>

TABLE 1 – BRINE POND CONSTRUCTION INSPECTION ACTIVITIES

GEOMEMBRANE LINERS		
SPECIFICATION	QUALITY CONTROL	QUALITY ASSURANCE
	defective seam between holes previously patched and vacuum tested shall be either capped and vacuum tested or, if the seam was welded using the fusion welding method, the loose flap of the upper sheet (which extends beyond the outer track) shall be extrusion welded to the bottom sheet and vacuum tested. In the latter case, where the loose flap of the upper sheet is extrusion welded to the bottom sheet, the extrusion weld becomes the primary seam.	been recorded. Follow procedures indicated above if results indicate a seam failure.
<b>CERTIFICATION:</b> At the completion of the geomembrane installation the installer shall provide the Owner with a certification stating that the geomembrane was installed and tested in accordance with the Specifications together with a report of the test results.	Provide Owner with the certification and the report of the test results as a digital and hard copy prior to the demobilization of the installation personnel from the site and no later than 30 days after the installation has been completed.	Participate in final walk through and inspection of the project with UDWRi designated personnel from Dam Safety Section and representatives from UDWQ.
<b>COMPLETION:</b> At the completion of the installation, the Installer shall provide a set of record drawings showing the actual geomembrane panel layout, seams location of destructive test samples, and the location of major repairs including repaired seams and capped areas.	Provide CQA personnel and Owner with set of record drawings no later than 30 days after the installation work has been completed.	Provide CQA Officer with record drawings completed by and according to CQA personnel observations showing the actual geomembrane panel layout. CQA officer is to review and approve CQA personnel record drawings. CQA officer is to review and approve installer provided record drawings. Upon approval of CQA Officer, provide record drawings to the Owner and include them in the final CQA report to be submitted to UDWQ and UDWRi.

\*SUPERSEDED\*

**\*Appendix B – Technical Specifications (NewFields, 2021) Supersedes this page**

# APPENDIX A

## TESTING FREQUENCY TABLES

From Approved Technical Specifications – Completed by AMEC

**\*SUPERSEDED**

**5.0 TABLE 1–TEST METHODS**

Test	Type of Test	Test Method (ASTM)
C1, R1	Atterberg limits	D4318
C2, R2	Moisture content	D2216
C3, R3	Particle size distribution	D422 <sup>a</sup>
C4, R4	Laboratory compaction	D1557
R5a	Nuclear density	D2922
R5b	Sand cone	D1556
R5c	Water replacement	D2167
C6, R6	Laboratory permeability	D5084

**Notes:**

C = Control Tests; R = Record Tests

<sup>a</sup> Hydrometer tests down to the 2-micron size will be carried out as directed by the QA Engineer but will generally not be required; all samples to be wash graded over a #200 sieve.

**6.0 TABLE 2–TEST FREQUENCY–RANDOM FILL**

Test	Type of Test	Frequency (1 per)
R1	Atterberg limits	50,000 yd <sup>3</sup>
C2, R2	Moisture content	Minimum of 1 per lift per day of production or 15,000 yd <sup>3</sup>
C3, R3	Particle size distribution	50,000 yd <sup>3</sup>
C4, R4	Laboratory compaction	Minimum 1 per Soil type or 200,000 yd <sup>3</sup>
R5a	Nuclear density	Minimum of 1 per lift per day of production or 15,000 yd <sup>3</sup>
R5b/R5c	Sand cone or water replacement density	1 per 10 nuclear density tests
C8, R8	Shear strength	1 per 1,000,000 yd <sup>3</sup>

### 7.0 TABLE 10–TEST FREQUENCY–CLEAN GRAVEL

Test	Type of Test	Frequency (1 per)
C3, R3	Particle size distribution	1,000 yd <sup>3</sup> or minimum 2 tests

Note: Sample sizes to be sampled in accordance with ASTM standards.

### 8.0 TABLE 11–TEST FREQUENCY–EMBANKMENT FOUNDATION

Test	Type of Test	Frequency (1 per)
R1	Atterberg limits	Lesser of soil type/100,000 ft <sup>2</sup>
C2, R2	Moisture content	50,000 ft <sup>2</sup>
C3, R3	Particle size distribution	100,000 ft <sup>2</sup>
C4, R4	Laboratory compaction	Lesser of soil type/250,000 ft <sup>2</sup>
R5a	Nuclear density	50,000 ft <sup>2</sup>
R5b	Sand cone density	1 per 10 nuclear density tests

### 9.0 TABLE 12–TEST FREQUENCY–BASIN FOUNDATION

Test	Type of Test	Frequency (1 per)
R1	Atterberg limits	Lesser of soil type/200,000 ft <sup>2</sup>
C2, R2	Moisture content	100,000 ft <sup>2</sup>
C3, R3	Particle size distribution	200,000 ft <sup>2</sup>
C4, R4	Laboratory compaction	Lesser of soil type/500,000 ft <sup>2</sup>
R5a	Nuclear density	100,000 ft <sup>2</sup>
R5b	Sand cone or water replacement density	1 per 10 nuclear density tests



**TABLE 1 – HDPE GEOMEMBRANE, SMOOTH**

Properties	Test Method	Test Value							Testing Frequency (minimum)
		30 mils	40 mils	50 mils	60 mils	80 mils	100 mils	120 mils	
Thickness (min. avg.) ▪ Lowest individual of 10 values	D5199	Nominal -10%	Nominal -10%	Nominal -10%	Nominal -10%	Nominal -10%	Nominal -10%	Nominal -10%	Per roll
Density mg/L (min.)	D1505/D792	0.940 g/cc	0.940 g/cc	0.940 g/cc	0.940 g/cc	0.940 g/cc	0.940 g/cc	0.940 g/cc	200,000 lbs
Tensile Properties <sup>1</sup> (min. avg.) ▪ Yield strength ▪ Break strength ▪ Yield elongation ▪ Break elongation	D6693 Type IV	63 lbs/in 114 lbs/in 12% 700%	84 lbs/in 152 lbs/in 12% 700%	105 lbs/in 190 lbs/in 12% 700%	126 lbs/in 228 lbs/in 12% 700%	168 lbs/in 304 lbs/in 12% 700%	210 lbs/in 360 lbs/in 12% 700%	252 lbs/in 456 lbs/in 12% 700%	20,000 lbs
Tear Resistance (min. avg.)	D1004	21 lbs	28 lbs	35 lbs	42 lbs	56 lbs	70 lbs	84 lbs	45,000 lbs
Puncture Resistance (min. avg.)	D4833	54 lbs	72 lbs	90 lbs	108 lbs	144 lbs	180 lbs	216 lbs	45,000 lbs
Stress Crack Resistance <sup>2</sup>	D5397 (Appendix)	300 hrs	300 hrs	300 hrs	300 hrs	300 hrs	300 hrs	300 hrs	Per GRI-GM10
Carbon Black Content (range)	D1603 <sup>3</sup>	2.0-3.0%	2.0-3.0%	2.0-3.0%	2.0-3.0%	2.0-3.0%	2.0-3.0%	2.0-3.0%	20,000 lbs
Carbon Black Dispersion	D5596	Note <sup>4</sup>	Note <sup>4</sup>	Note <sup>4</sup>	Note <sup>4</sup>	Note <sup>4</sup>	Note <sup>4</sup>	Note <sup>4</sup>	45,000 lbs
Oxidative Induction Time (OIT) (min. avg.) <sup>5</sup> a) Standard OIT --OR-- b) High Pressure OIT	D3895  D5885	100 min.  400 min.	100 min.  400 min.	100 min.  400 min.	100 min.  400 min.	100 min.  400 min.	100 min.  400 min.	100 min.  400 min.	200,000 lbs
Oven Aging at 85°C <sup>3,6</sup> a) Standard OIT (min. avg.) - % retained after 90 days --OR-- b) High Pressure OIT (min. avg.) - % retained after 90 days	D5721  D3895  D5885	  55%  80%	  55%  80%	  55%  80%	  55%  80%	  55%  80%	  55%  80%	  55%  80%	Per each formulation

Properties	Test Method	Test Value							Testing Frequency (minimum)
		30 mils	40 mils	50 mils	60 mils	80 mils	100 mils	120 mils	
UV Resistance <sup>7</sup> a) Standard OIT (min. avg.) --OR-- b) High Pressure OIT (min. avg.) - % retained after 1,600 hrs <sup>8</sup>	GM11 D3895  D5885	N.R. <sup>8</sup>  50%	N.R. <sup>8</sup>  50%	N.R. <sup>8</sup>  50%	N.R. <sup>8</sup>  50%	N.R. <sup>8</sup>  50%	N.R. <sup>8</sup>  50%	N.R. <sup>8</sup>  50%	Per each formulation

<sup>1</sup> Machine direction (MD) and cross-machine direction (XMD) average values should be based on five (5) test specimens each direction.  
 ▪ Yield elongation is calculated using a gauge length of 1.3 inches.  
 ▪ Break elongation is calculated using a gauge length of 2.0 inches.

<sup>2</sup> The yield stress used to calculate the applied load for the SP-NCTL test should be the manufacturer's mean value via MQC testing.

<sup>3</sup> Other methods, such as D4218 (muffle furnace) or microwave methods, are acceptable if an appropriate correlation to D1603 (tube furnace) can be established.

<sup>4</sup> Carbon black dispersion (only near spherical agglomerates) for ten (10) different views: Nine (9) in Categories 1 or 2 and one (1) in Category 3.

<sup>5</sup> The manufacturer has the option to select either one of the OIT methods listed to evaluate the antioxidant content in the geomembrane.

<sup>6</sup> It is also recommended to evaluate samples at 30 and 90 days to compare with the 90-day response.

<sup>7</sup> The condition of the test should be 20-hour UV cycle at 75°C followed by 4-hour condensation at 60°C.

<sup>8</sup> Not recommended since the high temperature of the Std-OIT test produces an unrealistic result for some of the antioxidants in the UV-exposed samples.

<sup>9</sup> UV resistance is based on percent retained value regardless of the original HP-OIT value.

**TABLE 2 – HDPE GEOMEMBRANE, TEXTURED**

Properties	Test Method	Test Value							Testing Frequency (minimum)
		30 mils	40 mils	50 mils	60 mils	80 mils	100 mils	120 mils	
Thickness (min. avg.) ▪ Lowest individual of 10 values	D5994	Nominal (-5%) -10%	Nominal (-5%) -10%	Nominal (-5%) -10%	Nominal (-5%) -10%	Nominal (-5%) -10%	Nominal (-5%) -10%	Nominal (-5%) -10%	Per roll
Asperity Height mils (min. avg.) <sup>1</sup>	GM 12	10 mil	10 mil	10 mil	10 mil	10 mil	10 mil	10 mil	Every 2 <sup>nd</sup> roll <sup>2</sup>
Density mg/L (min.)	D1505/D792	0.940 g/cc	0.940 g/cc	0.940 g/cc	0.940 g/cc	0.940 g/cc	0.940 g/cc	0.940 g/cc	200,000 lbs
Tensile Properties <sup>3</sup> (min. avg.) ▪ Yield strength ▪ Break strength ▪ Yield elongation ▪ Break elongation	D6693 Type IV	63 lbs/in 45 lbs/in 12% 150%	84 lbs/in 60 lbs/in 12% 150%	105 lbs/in 75 lbs/in 12% 150%	126 lbs/in 90 lbs/in 12% 150%	168 lbs/in 120 lbs/in 12% 150%	210 lbs/in 150 lbs/in 12% 150%	252 lbs/in 180 lbs/in 12% 150%	20,000 lbs
Tear Resistance (min. avg.)	D1004	21 lbs	28 lbs	35 lbs	42 lbs	56 lbs	70 lbs	84 lbs	45,000 lbs
Puncture Resistance (min. avg.)	D4833	54 lbs	72 lbs	90 lbs	108 lbs	144 lbs	180 lbs	216 lbs	45,000 lbs
Stress Crack Resistance <sup>4</sup>	D5397 (App.)	300 hrs	300 hrs	300 hrs	300 hrs	300 hrs	300 hrs	300 hrs	Per GRI-GM10
Carbon Black Content (range)	D1603 <sup>5</sup>	2.0-3.0%	2.0-3.0%	2.0-3.0%	2.0-3.0%	2.0-3.0%	2.0-3.0%	2.0-3.0%	20,000 lbs
Carbon Black Dispersion	D5596	Note <sup>6</sup>	Note <sup>6</sup>	Note <sup>6</sup>	Note <sup>6</sup>	Note <sup>6</sup>	Note <sup>6</sup>	Note <sup>6</sup>	45,000 lbs
Oxidative Induction Time (OIT) (min. avg.) <sup>7</sup> c) Standard OIT --OR-- d) High Pressure OIT	D3895  D5885	100 min.  400 min.	100 min.  400 min.	100 min.  400 min.	100 min.  400 min.	100 min.  400 min.	100 min.  400 min.	100 min.  400 min.	200,000 lbs
Oven Aging at 85°C <sup>7,8</sup> c) Standard OIT (min. avg.) - % retained after 90 days --OR-- d) High Pressure OIT (min. avg.) - % retained after 90 days	D5721  D3895  D5885	  55%  80%	  55%  80%	  55%  80%	  55%  80%	  55%  80%	  55%  80%	  55%  80%	  Per each formulation

Properties	Test Method	Test Value							Testing Frequency (minimum)
		30 mils	40 mils	50 mils	60 mils	80 mils	100 mils	120 mils	
UV Resistance <sup>9</sup> c) Standard OIT (min. avg.) --OR-- d) High Pressure OIT (min. avg.) - % retained after 1,600 hrs <sup>9</sup>	GM11 D3895  D5885	 N.R. <sup>8</sup>  50%	 N.R. <sup>8</sup>  50%	 N.R. <sup>8</sup>  50%	 N.R. <sup>8</sup>  50%	 N.R. <sup>8</sup>  50%	 N.R. <sup>8</sup>  50%	 N.R. <sup>8</sup>  50%	 Per each formulation

<sup>1</sup> Of 10 readings; 8 out of 10 readings must be ≥ 7 mils, and the lowest individual reading must be ≥ 5 mils

<sup>2</sup> Alternate the measurement side for double-sided textured sheet.

<sup>3</sup> Machine direction (MD) and cross-machine direction (XMD) average values should be on the basis of five (5) test specimens each direction.  
▪ Yield elongation is calculated using a gauge length of 1.3 inches.  
▪ Break elongation is calculated using a gauge length of 2.0 inches.

<sup>4</sup> P-NCTL test is not appropriate for testing geomembranes with textured or irregular rough surfaces. Test should be conducted on smooth edges of textured rolls or on smooth sheets made from the same formulation as being used for the textured sheet materials.

The yield stress used to calculate the applied load for the SP-NCTL test should be the manufacturer's mean value via MQC testing.

<sup>5</sup> Other methods, such as D4218 (muffle furnace) or microwave methods, are acceptable if an appropriate correlation to D1603 (tube furnace) can be established.

<sup>6</sup> Carbon black dispersion (only near spherical agglomerates) for ten (10) different views: Nine (9) in Categories 1 or 2 and one (1) in Category 3.

<sup>7</sup> The manufacturer has the option to select either one of the OIT methods listed to evaluate the antioxidant content in the geomembrane.

<sup>8</sup> It is also recommended to evaluate samples at 30 and 60 days to compare with the 90-day response.

<sup>9</sup> The condition of the test should be 20-hour UV cycle at 75°C followed by 4-hour condensation at 60°C.

<sup>10</sup> Not recommended since the high temperature of the Std-OIT test produces an unrealistic result for some of the antioxidants in the UV-exposed samples.

<sup>11</sup> UV resistance is based on percent-retained value regardless of the original HP-OIT value.



TABLE 3 – HDPE GEOMEMBRANE, DRAIN LINER

Properties	Test Method	Test Value				Testing Frequency (minimum)
		50 mils	60 mils	80 mils	100 mils	
Thickness (min. avg.) ▪ Lowest individual of 10 values	D5994	Nominal (-5%) -10%	Nominal (-5%) -10%	Nominal (-5%) -10%	Nominal (-5%) -10%	Per roll
Drainage Stud Height (min. avg.) <sup>1</sup>	GM 12	130 mil	130 mil	130 mil	130 mil	Every 2 <sup>nd</sup> roll <sup>2</sup>
Density mg/L (min.)	D1505/D792	0.940 g/cc	0.940 g/cc	0.940 g/cc	0.940 g/cc	200,000 lbs
Tensile Properties <sup>3</sup> (min. avg.) ▪ Yield strength ▪ Break strength ▪ Yield elongation ▪ Break elongation	D6693 Type IV	110 lbs/in 110 lbs/in 13% 300%	132 lbs/in 132 lbs/in 13% 300%	176 lbs/in 176 lbs/in 13% 300%	220 lbs/in 220 lbs/in 13% 300%	20,000 lbs
Tear Resistance (min. avg.)	D1004	38 lbs	50 lbs	67 lbs	83 lbs	45,000 lbs
Puncture Resistance (min. avg.)	D4833	80 lbs	95 lbs	126 lbs	158 lbs	45,000 lbs
Stress Crack Resistance <sup>4</sup>	D5397 (App.)	300 hrs	300 hrs	300 hrs	300 hrs	Per GRI-GM10
Carbon Black Content (range)	D1603 <sup>5</sup>	2.0-3.0%	2.0-3.0%	2.0-3.0%	2.0-3.0%	20,000 lbs
Carbon Black Dispersion	D5596	Note <sup>6</sup>	Note <sup>6</sup>	Note <sup>6</sup>	Note <sup>6</sup>	45,000 lbs
Oxidative Induction Time (OIT) (min. avg.) <sup>7</sup> e) Standard OIT --OR-- f) High Pressure OIT	D3895 D5885	≥100 min.	≥100 min.	≥100 min.	≥100 min.	200,000 lbs
Oven Aging at 85°C <sup>7,8</sup> e) Standard OIT (min. avg.) - % retained after 90 days --OR-- f) High Pressure OIT (min. avg.) - % retained after 90 days	D5721 D3895 D5885	N.R. N.R. 80%	N.R. N.R. 80%	N.R. N.R. 80%	N.R. N.R. 80%	Per each formulation

Properties	Test Method	Test Value				Testing Frequency (minimum)
		50 mils	60 mils	80 mils	100 mils	
UV Resistance <sup>9</sup> e) Standard OIT (min. avg.) --OR-- f) High Pressure OIT (min. avg.) - % retained after 1,600 hrs <sup>9</sup>	GM11 D3895 D5885	N.R. <sup>8</sup> N.R. <sup>8</sup> 50%	N.R. <sup>8</sup> N.R. <sup>8</sup> 50%	N.R. <sup>8</sup> N.R. <sup>8</sup> 50%	N.R. <sup>8</sup> N.R. <sup>8</sup> 50%	Per each formulation

<sup>1</sup> Of 10 readings; 8 out of 10 readings must be ≥ 7 mils, and the lowest individual reading must be ≥ 5 mils

<sup>2</sup> Alternate the measurement side for double-sided textured sheet.

<sup>3</sup> Machine direction (MD) and cross-machine direction (XMD) average values should be on the basis of five (5) test specimens each direction.

- Yield elongation is calculated using a gauge length of 1.3 inches.
- Break elongation is calculated using a gauge length of 2.0 inches.

<sup>4</sup> P-NCTL test is not appropriate for testing geomembranes with textured or irregular rough surfaces. Test should be conducted on smooth edges of textured rolls or on smooth sheets made from the same formulation as being used for the textured sheet materials.

The yield stress used to calculate the applied load for the SP-NCTL test should be the manufacturer's mean value via MQC testing.

<sup>5</sup> Other methods, such as D4218 (muffle furnace) or microwave methods, are acceptable if an appropriate correlation to D1603 (tube furnace) can be established.

<sup>6</sup> Carbon black dispersion (only near spherical agglomerates) for ten (10) different views: Nine (9) in Categories 1 or 2 and one (1) in Category 3.

<sup>7</sup> The manufacturer has the option to select either one of the OIT methods listed to evaluate the antioxidant content in the geomembrane.

<sup>8</sup> It is also recommended to evaluate samples at 30 and 60 days to compare with the 90-day response.

<sup>9</sup> The condition of the test should be 20-hour UV cycle at 75°C followed by 4-hour condensation at 60°C.

<sup>10</sup> Not recommended since the high temperature of the Std-OIT test produces an unrealistic result for some of the antioxidants in the UV-exposed samples.

<sup>11</sup> UV resistance is based on percent-retained value regardless of the original HP-OIT value.

**TABLE 4 – SEAM STRENGTH AND RELATED PROPERTIES OF THERMALLY BONDED  
SMOOTH AND TEXTURED HDPE GEOMEMBRANES**

<b>Geomembrane Nominal Thickness</b>	<b>30 mils</b>	<b>40 mils</b>	<b>50 mils</b>	<b>60 mils</b>	<b>80 mils</b>	<b>100 mils</b>	<b>120 mils</b>
<b>Hot Wedge Seams <sup>1</sup></b>							
Shear strength <sup>2</sup> , lb/in.	57	80	100	120	160	200	240
Shear elongation at break <sup>3</sup> , %	50	50	50	50	50	50	50
Peel strength <sup>2</sup> , lb/in.	45	64	76	91	121	151	181
Peel separation, %	25	25	25	25	25	25	25
<b>Extrusion Fillet Seams</b>							
Shear strength <sup>2</sup> , lb/in.	57	80	100	120	160	200	240
Shear elongation at break <sup>3</sup> , %	50	50	50	50	50	50	50
Peel strength <sup>2</sup> , lb/in.	39	52	65	78	104	130	156
Peel separation, %	25	25	25	25	25	25	25

<sup>1</sup> Also for hot air and ultrasonic seaming methods

<sup>2</sup> Value listed for shear and peel strengths are for four out of five test specimens; the fifth specimen can be as low as 80% of the listed values

<sup>3</sup> Elongation measurements should be omitted for field testing

**\*SUPERSEDED\***

## APPENDIX B

### NON-DESTRUCTIVE SEAM TESTING PROCEDURES

**\*SUPERSEDED**

## B.1 Procedure for Fusion Weld Testing

This test is intended to provide a nondestructive evaluation of the integrity of geomembrane seams made in the form of two closely spaced tracks by the fusion weld technique. The presence of the un-welded channel between the two distinct seamed regions allows for inflation of the sealed channel with air to a predetermined pressure. Extremely long lengths of seam can be evaluated, e.g., greater than 300 feet. The tightness of the pressurized air channel over time is noted and recorded. If air pressure cannot be maintained, a leak in the seam is indicated and corrective actions are taken.

The fusion weld technique utilizes a dual, or double, bonded seam where an air channel exists between the two seam tracks. Both ends of the air channel are sealed as designated below using Alternative A or Alternative B with a hollow needle with attached pressure gage inserted into the air space. Air pressure is applied and the gage is monitored for excessive air pressure drop. Air pressures are related to the thickness and stiffness of the geomembrane and vary from 24 to 30 lb/in<sup>2</sup>. Monitoring time shall be a minimum of 5 minutes. Maximum allowable loss of air pressure varies from 2 to 4 lb/in<sup>2</sup> depending upon thickness and stiffness of the geomembrane.

A hot air device is necessary to seal either one or both ends of the air channel. Wide mouth vice grips are sometimes necessary to further lock-off these sealed ends. A sharp, hollow needle with a properly functioning pressure gage is necessary to insert air into the open channel and monitor its pressure. An air pump capable of generating and sustaining the required air pressures is necessary. The pump is not to be attached while the air pressure is being monitored.

The procedure for conducting the non-destructive test on a fusion weld seam shall be as follows:

1. After making the desired dual track seam and deciding upon the length of seam that is to be evaluated, seal off the two ends of the continuous air channel and insert the air pressure needle into the air channel using either Alternative A or Alternative B below.

Alternative A: Heat both of the ends of the air channel with a hot air device. Clamp both ends of the air channel with wide-mouth vice grips so as to form an air-tight seal at both ends of the channel. The wide-mouth vice grips can remain in place throughout the test or be removed as the installer sees fit.

Insert the air pressure needle into the air channel by penetrating the upper geomembrane. The needle is to be inserted at the shallowest possible angle and only until the upper sheet is penetrated. The lower sheet beneath the air channel must not be penetrated. The pressure gage is connected directly to the end of the hollow needle. If problems are encountered in obtaining a good seal around the needle, heating of the needle with hot air may be helpful.

Alternative B: Seal off one end of the air channel by heating the end with the hot air device. Clamp this end of the air channel with wide-mouth vice grips so as to form an

air-tight seal at this end of the channel. The wide-mouth vice grips can remain in place throughout the test or be removed as the installer sees fit.

Insert the air pressure needle with attached pressure gage into the air space at the other end of the channel. The needle is to be fitted with a prefabricated end piece which can be clamped onto the other end of the air channel with vice grips so as to form an air tight seal around the needle and at the end of the air channel. Clamp the needle with prefabricated end piece onto the end of the air channel with vice grips so as to form an air-tight seal at this end of the channel.

2. Connect an air pump to the pressure gage and pressurize the air channel. The pressure schedule for high density polyethylene (HDPE) geomembranes is as follows:

Geomembrane Thickness (mil)	Minimum Pressure (lb/in <sup>2</sup> )	Maximum Pressure (lb/in <sup>2</sup> )
60	30	35
80	30	35

Maintain these pressures with the air pump connected during a two-minute stabilization period.

3. Disconnect the air pump. Observe the air pressure gage for a minimum of 3 minutes. Record the time and pressure of the beginning and end of the test. The maximum allowable pressure drop should not exceed the following schedule.

Geomembrane Thickness (mil)	Maximum Pressure Drop (lb/in <sup>2</sup> )
60	3.0
80	3.0

4. If the pressure does not drop below the above value after the minimum 3 minute test period, cut the air channel open at the end away from the pressure gage. Air should rush out and the pressure gage should register an immediate drop in pressure, indicating that the entire length of the seam has been tested. If this does not happen, the air channel is blocked. Walk the seam to look and feel for the location of the blockage. The channel should be inflated up to that point.

Cut the air channel on the gage side of the blockage and verify the pressure loss. Then inflate the weld from the far side. If the pressure holds, cut the seam just prior to the blockage and verify the pressure drop. If the location of the blockage can not be found, it may be necessary to cut the seam in the middle and treat both halves as separate welds. Patch all cuts and seal small holes with extrudate from a fillet extrusion seam device.

Note 1: If multiple blocked locations are suspected or if the seam is short, it may be easiest to cut the seam out and remake the weld.

5. For a pressure drop greater than the above value, check the end seals and where the needle enters into the air channel. Reseal these areas with a hand held hot air device if a leak is noticed and then repeat the entire test.

Note 2: Leaks around the end seals and air pressure insertion needle can usually be located by putting moisture around the suspected area and looking for bubbles to occur.

6. If the problem is not located, perform peel tests at the beginning and end of the seam to determine seam strength.
7. If the seam strength is inadequate, the edge of the loose flap of the upper sheet (which extends beyond the outer track) is extrusion fillet welded to the bottom sheet. Thus the extrusion fillet weld becomes the primary seam. It is then vacuum box tested until satisfactory performance is obtained.
8. If the seam passes the destructive tests, the leak is looked for with the flap in place. If the leak is found, it is repaired. If it cannot be found, cut away the flap. Then vacuum box test the outer track of the seam. If a leak is found, repair it. In both cases, repairs are made by extrusion fillet welds.
9. If no leak is found in the outer track and all other leak location possibilities have been eliminated, the leak is assumed to be in the inner track. Since this inner track is for the purpose of air channel testing only, it is redundant and can be ignored. The single good outer track is adequate and should be accepted as such.

Note 3: If the outer air track cannot be accepted as the primary and only seam, a cap strip over the entire seam, or the entire seam cut out and rewelded, are alternative possibilities.

10. Record the results for seam air pressure testing.

## B.2 Procedure For Vacuum Testing

In those locations where extrusion welding is used, all of the welding will be vacuum tested. Defects found will be repaired and retested. Vacuum testing, repair procedures, and retesting will be recorded and made part of the CQA Report.

The procedure that will be followed for vacuum testing will conform to the procedure identified in ASTM Designation D4437-84 "Determining the Integrity of Field Seams Used in Joining Flexible Polymeric Sheet Geomembranes." This procedure will be followed with two exceptions. First, the vacuum pressure applied to the vacuum box will not be less than 5 psi which is in accordance with the current EPA specifications given in guidance memorandum, "Use of Construction Quality Assurance (CQA) Programs and Control of Stress Cracking in Flexible Membrane Liner's Seams," rather than the 4 to 8 inches of mercury (approximately 2 psi to 4 psi) as indicated in the ASTM D4437-84 standard. Second, a dwell time of 15 seconds will be specified in accordance with the EPA current guidance. There is no designated dwell time in the ASTM D4437-84 standard. The procedure will be as follows:

All seams welded using the extrusion process shall be inspected for unbonded areas by applying a vacuum to a soaped section of the seam. The vacuum shall be applied by a vacuum box equipped with a vacuum gage, a clear glass view panel in the top, and a soft rubber gasket on the periphery of the open bottom. Thoroughly soap a section of the seam and place the inspection box over the soaped seam section and the gasket sealed to the liner. Apply a vacuum of not less than 5 psi to the box by use of a vacuum pump. The vacuum will be applied for a minimum dwell time of fifteen (15) seconds. The applied vacuum will show bubbles over unbonded areas; the unbonded areas shall then be marked for repair.

Record the results for the vacuum testing.



## B.3 Procedure For Electrostatic Spark Test

The electrostatic spark test is a non-destructive test used to detect voids, pinholes, or unbonded areas primarily in HDPE extrusion welds. Seams tested by this method are provided with a copper wire properly embedded in the seam and grounded. A high voltage electric current is then applied to a probe which is slowly moved along the length of the seam and any leakage to ground (i.e., through a pinhole to the copper wire) is detected by sparking. Procedures for conducting the electrostatic spark test are as follows:

- A. Prepare the seam to be welded.
- B. Insert an 18 gauge bare copper wire in the seam area, where it will appear at the bottom of the weld after the seam is welded, with one end of the wire left exposed.
- C. Weld the seam.
- D. After the weld has cooled, connect the exposed end of the copper wire to the ground terminal on a high voltage spark tester capable of operating in a range of 10 to 55 KV.
- E. Turn the spark tester on and adjust the output voltage control to minimum. Hold the test probe on the spark tester near the exposed end of the copper wire and increase the output voltage until a spark can be obtained at least twice as long as the thickness of the material to be tested (or twice as thick as the weld).
- F. Move the probe slowly along the length of the welded seam. Document and mark on the HDPE liner adjacent to the weld locations where sparking is observed. Locations where sparking is observed indicates the presence of leaks in the weld.
- G. After testing the seam, verify that the length of the spark to the exposed end of the copper wire is still adequate before turning the power to the machine off. If the spark is not adequate, readjust the output voltage and retest the seam.
- H. Record the results from the spark test.
- I. Repair locations indicating the presence of a leak by grinding and re-welding.
- J. Retest repair area.

Signature: 

Email: egaddis@utah.gov

Signature:   
Woodrow Campbell (Mar 18, 2021 18:27 MDT)

Email: wwcampbell@utah.gov



**CONSTRUCTION PERMIT ISSUED BY  
Utah Department of Environmental Quality  
Utah Division of Water Quality**

Date: 03/18/2021

Review Engineer:   
WC

Director:   
EG



**DRAWINGS**

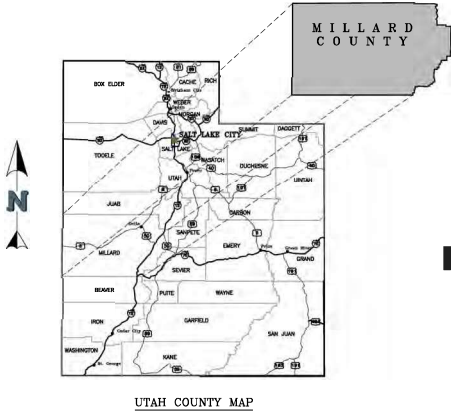

UTAH COUNTY MAP

# MAGNUM SOLUTION MINING, LLC

## BRINE POND 4

### RE-ISSUED FOR CONSTRUCTION 01/29/21

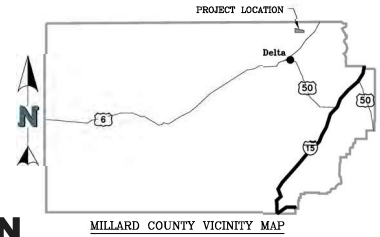

MILLARD COUNTY VICINITY MAP

DWG #	TITLE	REV
A000	COVER SHEET & DRAWING INDEX	1
A010	GENERAL ARRANGEMENT	0
A020	STAGE-STORAGE CURVES AND POND PROPERTIES	1
A050	GEOTECHNICAL INVESTIGATION LOCATIONS	0
A100	OVERALL GRADING PLAN	0
A105	OVERALL GRADING ISOPACH	0
A110	TYPICAL EMBANKMENT SECTIONS AND DETAILS SHEET 1 OF 2	0
A115	TYPICAL EMBANKMENT SECTIONS AND DETAILS SHEET 2 OF 2	1
A120	POND NO. 4 NORTHEAST ACCESS RAMP PLAN AND PROFILE	0
A135	POND NO. 4 SOUTHWEST ACCESS RAMP PLAN AND PROFILE	0
A140	BRINE RECOVERY SYSTEM SECTION AND DETAILS	0
A150	POND INLET PLAN	0
A160	POND INLET SECTIONS AND DETAILS	0
A200	POND BASIN PIPING PLAN	0
A205	POND BASIN PIPING SECTIONS AND DETAILS	0
A220	LEAK COLLECTION AND RECOVERY SYSTEM DETAILS	0
A230	PROCESS COLLECTION AND MONITORING SYSTEM PLAN	0
A300	POND SITE GROUNDWATER DEPTHS PLAN AND PROFILE	1
A400	STORMWATER DIVERSION AND SETTLEMENT MONUMENT PLAN	0
A500	BRINE RECOVERY MANIFOLD SECTIONS AND DETAILS	0
A600	WILDLIFE FENCE DETAILS	0

OWNER'S ACCEPTANCE OF THE DRAWINGS

Michael J. Ducker *Michael J. Ducker* 2/8/21  
 NAME SIGNATURE DATE



MAGNUM SOLUTION MINING, LLC  
 3165 E MILLROCK DRIVE  
 SUITE 330 HOLLADAY, UT 84121  
 PHONE: 801-993-7001



9400 Station Street, Suite 300, Lone Tree, CO 80124  
 Phone: (720) 508.3300 www.newfields.com

P:\Projects\0023\_0203\_Magnum Brine Pond\_4\_Rev.dwg - Design\_V-CAD\DWG\03\_0203\_0204.dwg - 9/15/2020 11:52 AM

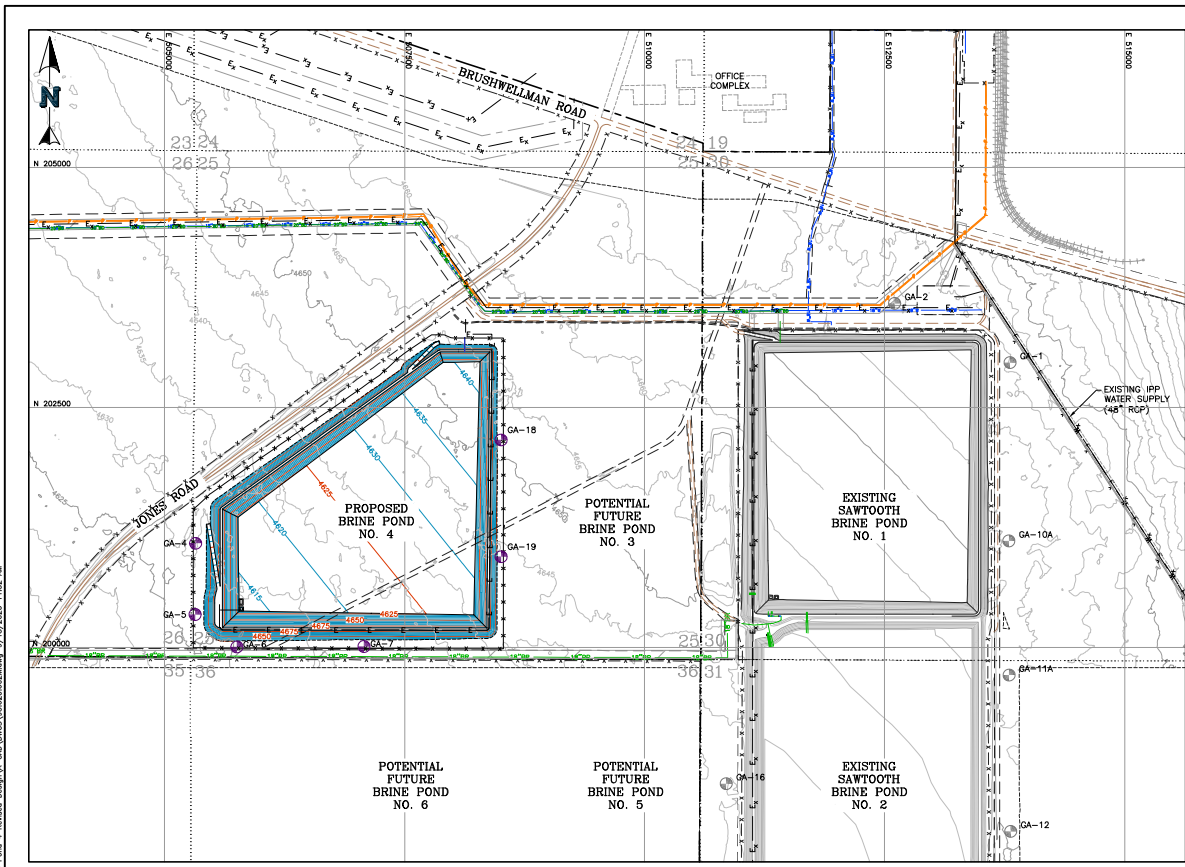

- LEGEND:**
- EXISTING GROUND CONTOURS
  - PROPOSED GROUND CONTOURS
  - EXISTING ROADS/TRAILS
  - EXISTING EASEMENTS
  - MAGNUM SITE BOUNDARY
  - SITE BOUNDARY
  - SECTION LINES
  - SECTION NUMBER
  - EXISTING FENCE
  - PROPOSED WILDLIFE FENCE
  - EXISTING BRINE LINE
  - EXISTING BRINE LINE
  - EXISTING POWER LINE
  - EXISTING WATER LINE
  - EXISTING PIPE
  - EXISTING 18" WATER
  - EXISTING 4" WATER
  - PROPOSED 20" HDPE DR11 BRINE INFLUENT LINE
  - EXISTING GROUND WATER MONITORING WELLS TO REMAIN
  - PROPOSED GROUND WATER MONITORING WELLS

**NOTES:**

- STAGE-STORAGE CURVES AND POND PROPERTIES TABLE ARE SHOWN ON DRAWING A010.



APPROVED BY:	KNJ	DISCLAIMER:	NEWFIELDS PRODUCED THE INFORMATION PRESENTED ON THIS DRAWING THROUGH THE USE OF AVAILABLE TECHNICAL INFORMATION AND EXPERIENCE. RECEIVING THIS DRAWING DOES NOT GUARANTEE ANY RIGHTS TO OTHER SUCH TECHNICAL INFORMATION OR EXPERIENCE. ANY MODIFICATION OR ADAPTATION OF THE DATA OR DRAWING SHALL BE AT USER'S RISK AND WITHOUT ANY LIABILITY OR LEGAL RESPONSIBILITY TO NEWFIELDS.
CHECKED BY:	JLW	DESIGNED BY:	JLW
DRAWN BY:	LE	DATE:	09/15/20
REV	DATE	DESCRIPTION	TECH

<b>NewFields</b>	CLIENT	MAGNUM SOLUTION MINING, LLC
PROJECT	BRINE POND 4	
TITLE	GENERAL ARRANGEMENT	
TOLERANCE	93.020.002M	REVISION
DRAWING NO.	A010	0

TABLE 1 - POND MATERIAL PROPERTIES AND TESTING FREQUENCY SUMMARY (SEE NOTE 4)

ASTM TEST (DESCRIPTION)	CONTROL & RECORD TEST No.	TESTING FREQUENCIES (ONE PER - SEE NOTE 2)					
		RANDOM FILL	SELECT GRAVEL	PIPE BEDDING/BACKFILL	ROAD WEARING COURSE	EMBANKMENT FOUNDATION	BASIN FOUNDATION
D4318 (ATTERBERG LIMITS)	C1, R1	10,000 yd <sup>3</sup>	1,000 yd <sup>3</sup>	SOIL TYPE/5,000 yd <sup>3</sup> OR 1 PER STRUCTURE	2,000 yd <sup>3</sup>	SOIL TYPE/100,000 ft <sup>2</sup>	SOIL TYPE/200,000 ft <sup>2</sup>
D2216 (MOISTURE CONTENT)	C2, R2	1 PER LIFT PER DAY OR 2,000 yd <sup>3</sup>	-	PER NUCLEAR DENSITY REQUIREMENTS	-	50,000 ft <sup>2</sup>	100,000 ft <sup>2</sup>
D422 (PARTICLE SIZE DISTRIBUTION)	C3, R3	10,000 yd <sup>3</sup>	1,000 yd <sup>3</sup> OR MINIMUM OF 2 TESTS	5,000 yd <sup>3</sup> OR 1 PER STRUCTURE	2,000 yd <sup>3</sup>	100,000 ft <sup>2</sup>	200,000 ft <sup>2</sup>
D698 (STANDARD PROCTOR)	C4, R4	SOIL TYPE/ 1 PER 10 FIELD DENSITY TESTS	-	SOIL TYPE/5,000 yd <sup>3</sup>	-	SOIL TYPE/250,000 ft <sup>2</sup>	SOIL TYPE/500,000 ft <sup>2</sup>
D2922 (NUCLEAR DENSITY)	R5a, R5b	1 PER LIFT PER DAY OR 2,000 yd <sup>3</sup>	-	GREATER OF 4 PER STRUCTURE OR 500 yd <sup>3</sup>	-	50,000 ft <sup>2</sup>	100,000 ft <sup>2</sup>
REQUIRED COMPACTION VALUES AND RESULTS (SEE NOTE 1)	MOISTURE CONTENT	WITHIN 2% OF OPTIMUM MOISTURE CONTENT	-	SUFFICIENT TO OBTAIN ADEQUATE DENSITY	-	SUFFICIENT TO OBTAIN ADEQUATE DENSITY	SUFFICIENT TO OBTAIN ADEQUATE DENSITY
	MIN. COMPACTION PER ASTM D698	AT LEAST 95% OF MAX. DRY DENSITY	-	AT LEAST 95% OF MAXIMUM DRY DENSITY	-	95% M.D.D.	95% M.D.D.
	MAXIMUM LOOSE LIFT THICKNESS	8"	-	8"	8"	SUFFICIENT TO ACHIEVE A SMOOTH AND COMPACT SURFACE	
MAXIMUM PARTICLE SIZE	4"	-	-	-	-	-	
D1556 (SAND CONE) OR D5030 (WATER REPLACEMENT)	R5b, R5c	1 PER 10 NUCLEAR DENSITY TESTS	-	EVERY 10 NUCLEAR DENSITY TESTS	-	1 PER 10 NUCLEAR DENSITY TESTS	1 PER 10 NUCLEAR DENSITY TESTS
D3080 (DIRECT SHEAR STRENGTH - SEE NOTE 3)	C6, R6	1 PER 1,000,000 yd <sup>3</sup>	-	-	-	-	-

TABLE 2 - PARTICLE SIZE DISTRIBUTION SUMMARY (SEE NOTE 4)

MATERIAL	4"	3"	2"	1.5"	1"	0.75"	0.5"	#4	#10	#200	P.I.
SELECT GRAVEL	100	100	100	30-70	0-15	0-5	0-5	35-50	15-40	2-10	<= 10
ROAD WEARING COURSE	100	90-100									<= 10
PIPE BACKFILL	100	90-100									<= 10
PIPE BEDDING				100	90-100	30-70			0-20	<= 10	

NOTES:

- IF 3 CONSECUTIVE TESTS FAIL FOR EITHER COMPACTION OR MOISTURE, THE TESTING FREQUENCY SHALL BE INCREASED TO 1 TEST PER 1,000 yd<sup>3</sup> UNTIL 6 CONSECUTIVE PASSING TESTS ARE RECORDED.
- WHERE TWO CRITERIA ARE GIVEN, WHICHEVER CRITERIA RESULTS IN MORE FREQUENT TESTING SHALL BE OBSERVED.
- D3080 (DIRECT SHEAR STRENGTH) REQUIREMENT IS A MINIMUM FRICTION ANGLE OF 30° AND A MINIMUM COHESION OF 300 PSF. IF RESULTS DO NOT ACHIEVE THESE MINIMUM CRITERIA, THE ENGINEER SHALL BE NOTIFIED TO RE-EVALUATE THE ANALYSIS.
- THE INFORMATION PRESENTED ON THIS DRAWING IS AN INCOMPLETE SUMMARY OF THE TECHNICAL SPECIFICATIONS. THE FULL TECHNICAL SPECIFICATIONS ARE INCLUDED IN APPENDIX B OF THE FINAL DESIGN REPORT AND MUST BE REFERRED TO DURING CONSTRUCTION.

BRINE POND NO. 4 STAGE-STORAGE CURVE

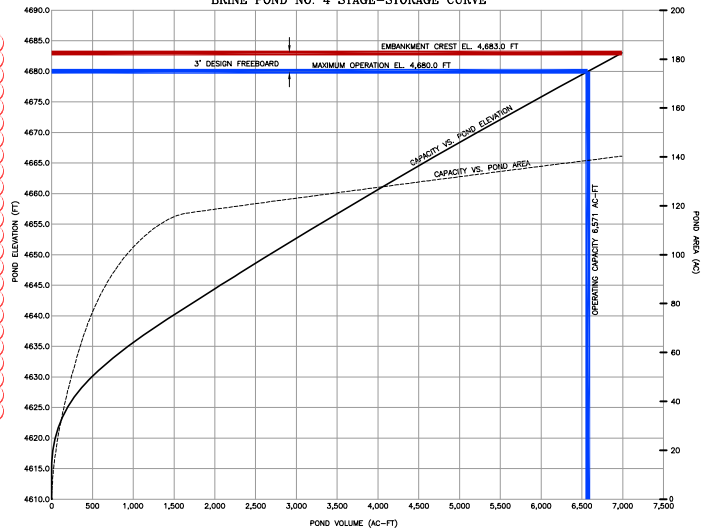

POND PROPERTIES

DESCRIPTION	POND NO. 4
CREST ELEVATION (FT)	4,683.0
OPERATING ELEVATION (FT)	4,680.0
TOTAL CAPACITY (AC-FT)	6,999
OPERATING CAPACITY (AC-FT)	6,571
FREEBOARD CAPACITY (AC-FT)	418

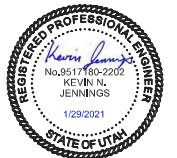

APPROVED BY: KNJ	DISCLAIMER: NEWFIELDS PRODUCED THE INFORMATION PRESENTED ON THIS DRAWING THROUGH THE USE OF AVAILABLE TECHNICAL INFORMATION AND EXPERIENCE RECEIVED THIS DRAWING DOES NOT GUARANTEE ANY RIGHTS TO OTHER SUCH TECHNICAL INFORMATION OR EXPERIENCE. ANY MODIFICATION OR ADAPTATION OF THE DATA OR DRAWING SHALL BE AT USER'S RISK AND WITHOUT ANY LIABILITY OR LEGAL RESPONSIBILITY TO NEWFIELDS.	CLIENT: MAGNUM SOLUTION MINING, LLC	PROJECT: BRINE POND 4	TITLE: STAGE-STORAGE CURVES AND POND PROPERTIES	DATE: 03/20/2020	REVISION: 1
1 02/16/20	ISSUED FOR CONSTRUCTION	JLF SKI				
2 02/16/20	ISSUED FOR CONSTRUCTION	JLF SKI				
REV	DATE	DESCRIPTION	TECH	ENG		

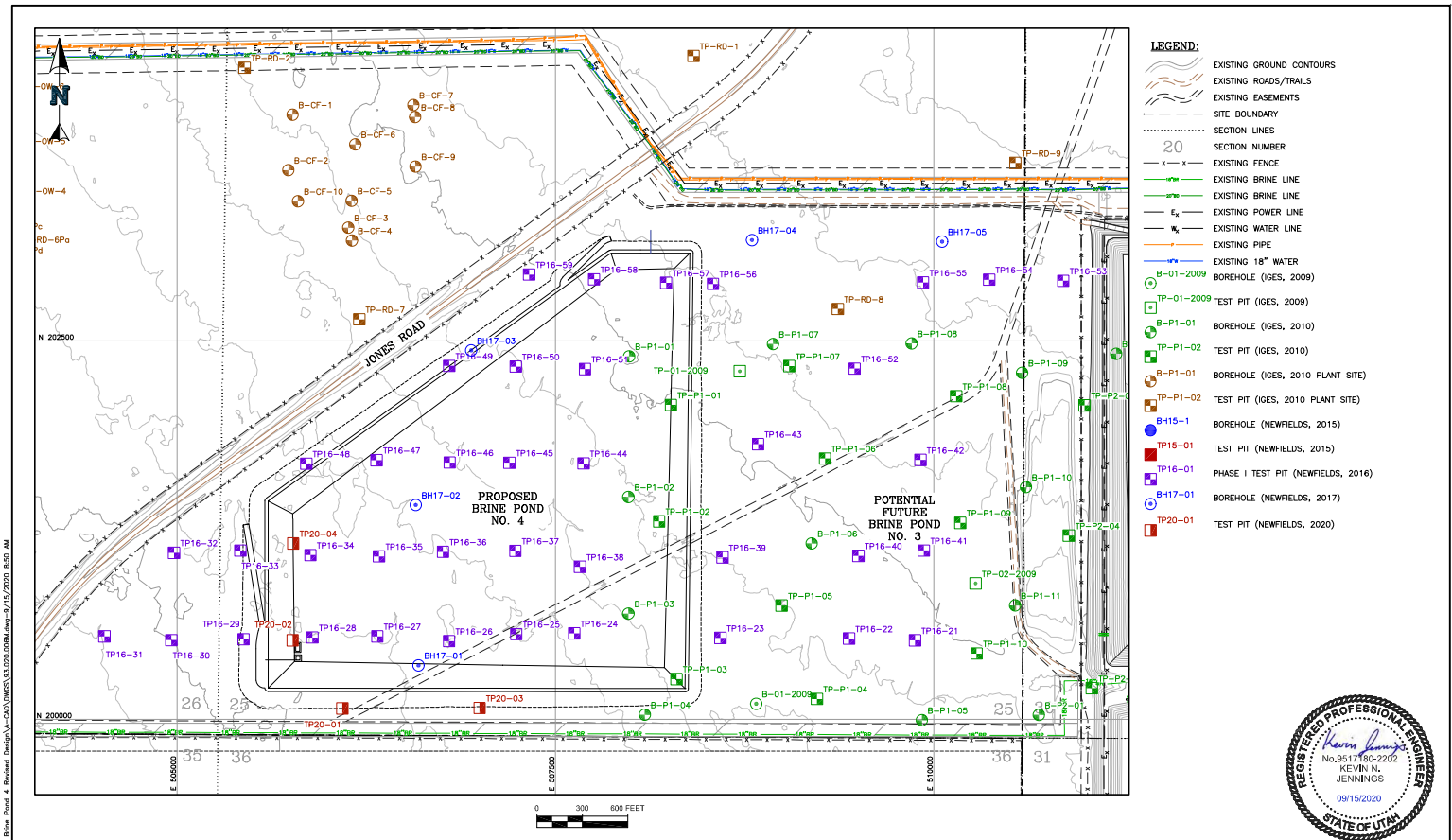

- LEGEND:**
- EXISTING GROUND CONTOURS
  - EXISTING ROADS/TRAILS
  - EXISTING EASEMENTS
  - SITE BOUNDARY
  - SECTION LINES
  - SECTION NUMBER
  - EXISTING FENCE
  - EXISTING BRINE LINE
  - EXISTING BRINE LINE
  - EXISTING POWER LINE
  - EXISTING WATER LINE
  - EXISTING PIPE
  - EXISTING 18" WATER
  - B-01-2009 BOREHOLE (IGES, 2009)
  - TP-01-2009 TEST PIT (IGES, 2009)
  - B-P1-01 BOREHOLE (IGES, 2010)
  - TP-P1-02 TEST PIT (IGES, 2010)
  - B-P1-01 BOREHOLE (IGES, 2010 PLANT SITE)
  - TP-P1-02 TEST PIT (IGES, 2010 PLANT SITE)
  - BH15-1 BOREHOLE (NEWFIELDS, 2015)
  - TP15-01 TEST PIT (NEWFIELDS, 2015)
  - TP16-01 PHASE I TEST PIT (NEWFIELDS, 2016)
  - BH17-01 BOREHOLE (NEWFIELDS, 2017)
  - TP20-01 TEST PIT (NEWFIELDS, 2020)



P:\Projects\0023\_1023\_Magnum Brine Pond\_4\_Revise Design\A-CAD\DWG\3.03.2020\0023\_1023\_01.dwg 9/15/2020 8:50 AM

APPROVED BY: KJM		DISCLAIMER		CLIENT: MAGNUM SOLUTION MINING, LLC	
CHECKED BY: JLW		NEWFIELDS PRODUCED THE INFORMATION PRESENTED ON THIS DRAWING THROUGH THE USE OF AVAILABLE TECHNICAL INFORMATION AND EXPERIENCE. RECEIVING THIS DRAWING DOES NOT GUARANTEE ANY RIGHTS TO OTHER SUCH TECHNICAL INFORMATION OR EXPERIENCE. ANY MODIFICATION OR ADAPTATION OF THE DATA OR DRAWING SHALL BE AT USER'S RISK AND WITHOUT ANY LIABILITY OR LEGAL RESPONSIBILITY TO NEWFIELDS.		PROJECT: BRINE POND 4	
DESIGNED BY: JLW		DRAWN BY: LE		TITLE: GEOTECHNICAL INVESTIGATION LOCATIONS	
REV	DATE	DESCRIPTION	TECH	ENG	TALKING: 93.020.009M DRAWING NO: A050 REVISION: 0

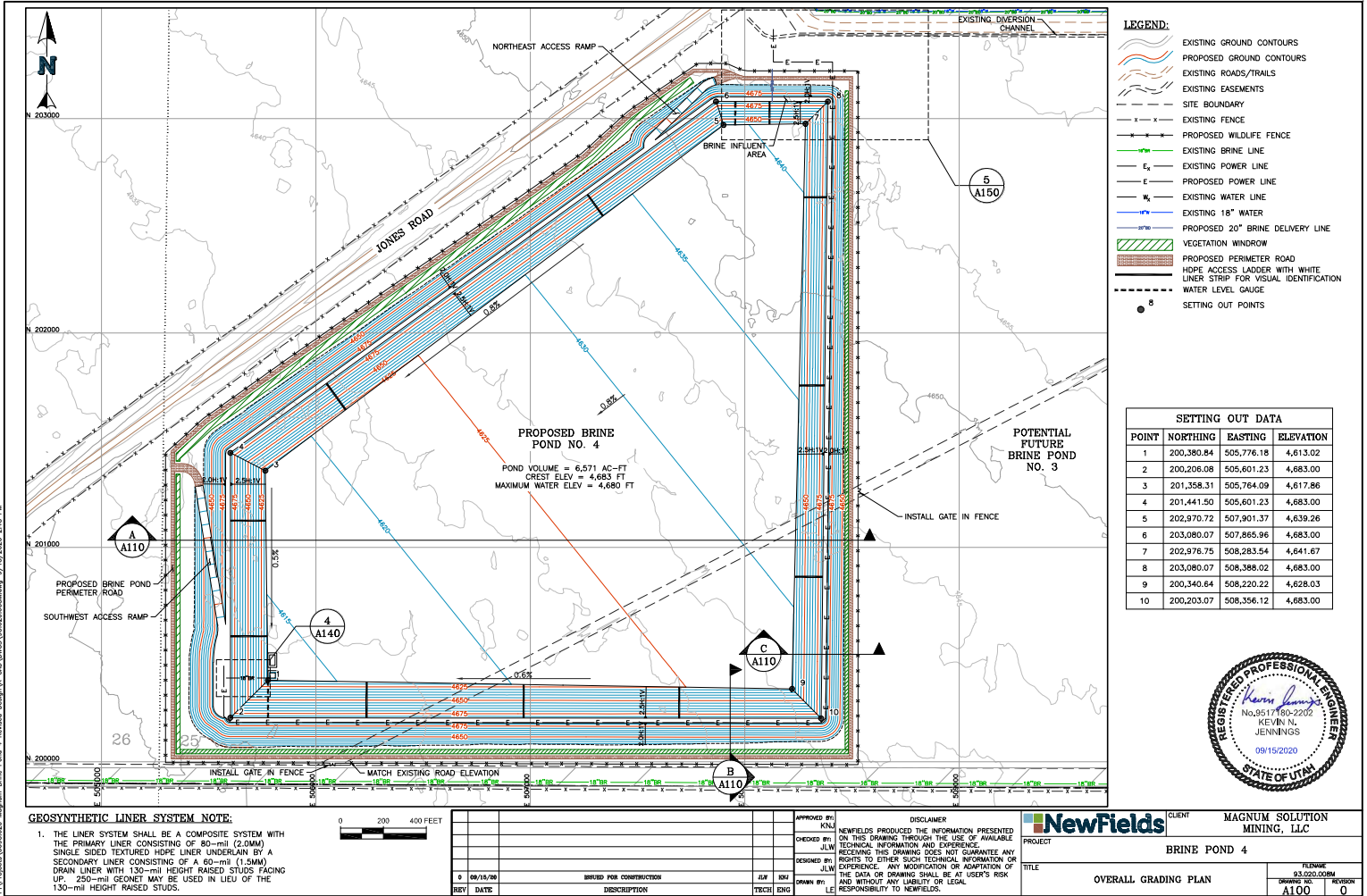

**LEGEND:**

- EXISTING GROUND CONTOURS
- PROPOSED GROUND CONTOURS
- EXISTING ROADS/TRAILS
- EXISTING EASEMENTS
- SITE BOUNDARY
- EXISTING FENCE
- PROPOSED WILDLIFE FENCE
- EXISTING BRINE LINE
- EXISTING POWER LINE
- PROPOSED POWER LINE
- EXISTING WATER LINE
- EXISTING 18" WATER
- PROPOSED 20" BRINE DELIVERY LINE
- VEGETATION WINDROW
- PROPOSED PERIMETER ROAD
- HDPE ACCESS LADDER WITH WHITE LINER STRIP FOR VISUAL IDENTIFICATION
- WATER LEVEL GAUGE
- SETTING OUT POINTS

SETTING OUT DATA			
POINT	NORTHING	EASTING	ELEVATION
1	200,380.84	505,776.18	4,613.02
2	200,208.08	505,601.23	4,683.00
3	201,358.31	505,764.09	4,617.86
4	201,441.50	505,601.23	4,683.00
5	202,970.72	507,901.37	4,639.26
6	203,080.07	507,865.96	4,683.00
7	202,978.75	508,283.54	4,641.67
8	203,080.07	508,388.02	4,683.00
9	200,340.64	508,220.22	4,628.03
10	200,203.07	508,356.12	4,683.00



**GEO-SYNTHETIC LINER SYSTEM NOTE:**

- THE LINER SYSTEM SHALL BE A COMPOSITE SYSTEM WITH THE PRIMARY LINER CONSISTING OF 80-mil (2.0MM) SINGLE SIDED TEXTURED HDPE LINER UNDERLAIN BY A SECONDARY LINER CONSISTING OF A 60-mil (1.5MM) DRAIN LINER WITH 130-mil HEIGHT RAISED STUDS FACING UP. 250-mil GEONET MAY BE USED IN LIEU OF THE 130-mil HEIGHT RAISED STUDS.



REV	DATE	DESCRIPTION	DESIGNED BY	CHECKED BY	DATE
1	09/15/20	ISSUED FOR CONSTRUCTION	JLW	KNJ	

APPROVED BY: KNJ  
 CHECKED BY: JLW  
 DESIGNED BY: JLW  
 DRAWN BY: LE

**DISCLAIMER:**  
 NEWFIELDS PRODUCED THE INFORMATION PRESENTED ON THIS DRAWING THROUGH THE USE OF AVAILABLE TECHNICAL INFORMATION AND EXPERIENCE. RECEIVING THIS DRAWING DOES NOT GUARANTEE ANY RIGHTS TO OTHER SUCH TECHNICAL INFORMATION OR EXPERIENCE. ANY MODIFICATION OR ADAPTATION OF THE DATA OR DRAWING SHALL BE AT USER'S RISK AND WITHOUT ANY LIABILITY OR LEGAL RESPONSIBILITY TO NEWFIELDS.

**NewFields** CLIENT: **MAGNUM SOLUTION MINING, LLC**

PROJECT: **BRINE POND 4**

TITLE: **OVERALL GRADING PLAN**

DATE: 09/15/2020  
 DRAWING NO: 93.020.009M  
 REVISION: A100 0

A:\Projects\0923\020\Magnum Brine Pond 4 Revised Design\A-CAD\DWG\93.020.009M.dwg - 9/15/2020 2:48 PM

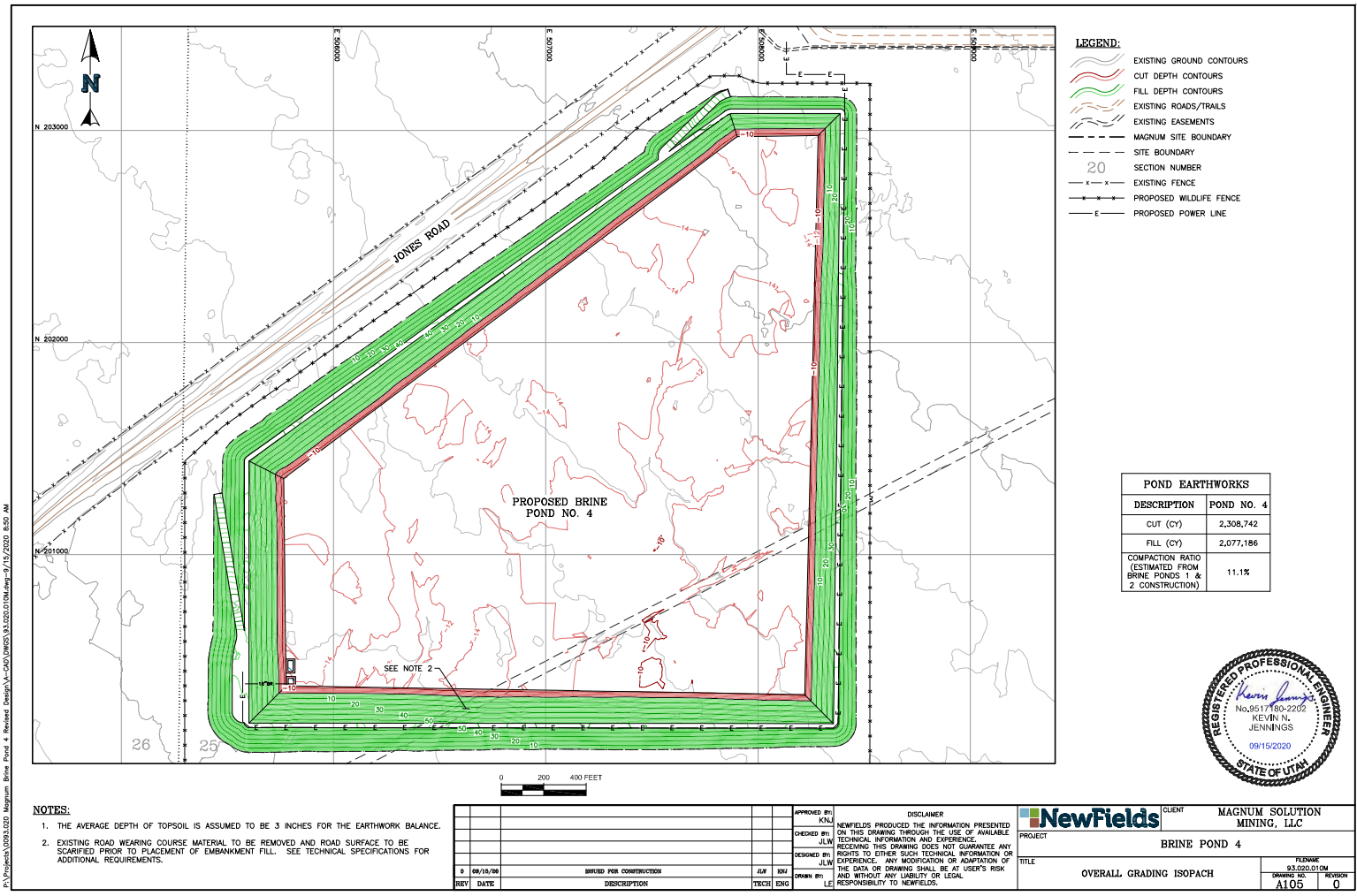

**LEGEND:**

- EXISTING GROUND CONTOURS
- CUT DEPTH CONTOURS
- FILL DEPTH CONTOURS
- EXISTING ROADS/TRAILS
- EXISTING EASEMENTS
- MAGNUM SITE BOUNDARY
- SITE BOUNDARY
- SECTION NUMBER
- EXISTING FENCE
- PROPOSED WILDLIFE FENCE
- PROPOSED POWER LINE

POND EARTHWORKS	
DESCRIPTION	POND NO. 4
CUT (CY)	2,308,742
FILL (CY)	2,077,186
COMPACTION RATIO (ESTIMATED FROM BRINE PONES 1 & 2 CONSTRUCTION)	11.1%



- NOTES:**
1. THE AVERAGE DEPTH OF TOPSOIL IS ASSUMED TO BE 3 INCHES FOR THE EARTHWORK BALANCE.
  2. EXISTING ROAD WEARING COURSE MATERIAL TO BE REMOVED AND ROAD SURFACE TO BE SCARIFIED PRIOR TO PLACEMENT OF EMBANKMENT FILL. SEE TECHNICAL SPECIFICATIONS FOR ADDITIONAL REQUIREMENTS.

APPROVED BY:	KNJ	DISCLAIMER:	NEWFIELDS PRODUCED THE INFORMATION PRESENTED ON THIS DRAWING THROUGH THE USE OF AVAILABLE TECHNICAL INFORMATION AND EXPERIENCE. RECEIVING THIS DRAWING DOES NOT GUARANTEE ANY RIGHTS TO OTHER SUCH TECHNICAL INFORMATION OR EXPERIENCE. ANY MODIFICATION OR ADAPTATION OF THE DATA OR DRAWING SHALL BE AT USER'S RISK AND WITHOUT ANY LIABILITY OR LEGAL RESPONSIBILITY TO NEWFIELDS.
CHECKED BY:	JLW	DESIGNED BY:	JLW
DRAWN BY:	LE	DATE:	09/15/20

<b>NewFields</b>	CLIENT	MAGNUM SOLUTION MINING, LLC
PROJECT	BRINE POND 4	
TITLE	OVERALL GRADING ISOPACH	FILENAME: 93.020.010M DRAWING NO.: A105 REVISION: 0

P:\Projects\00931\_0201\_Magnum Brine Pond\_4 Revised Design\_V-CAD\DWG\93.020.010.Mxd - 9/15/2020 8:50 AM



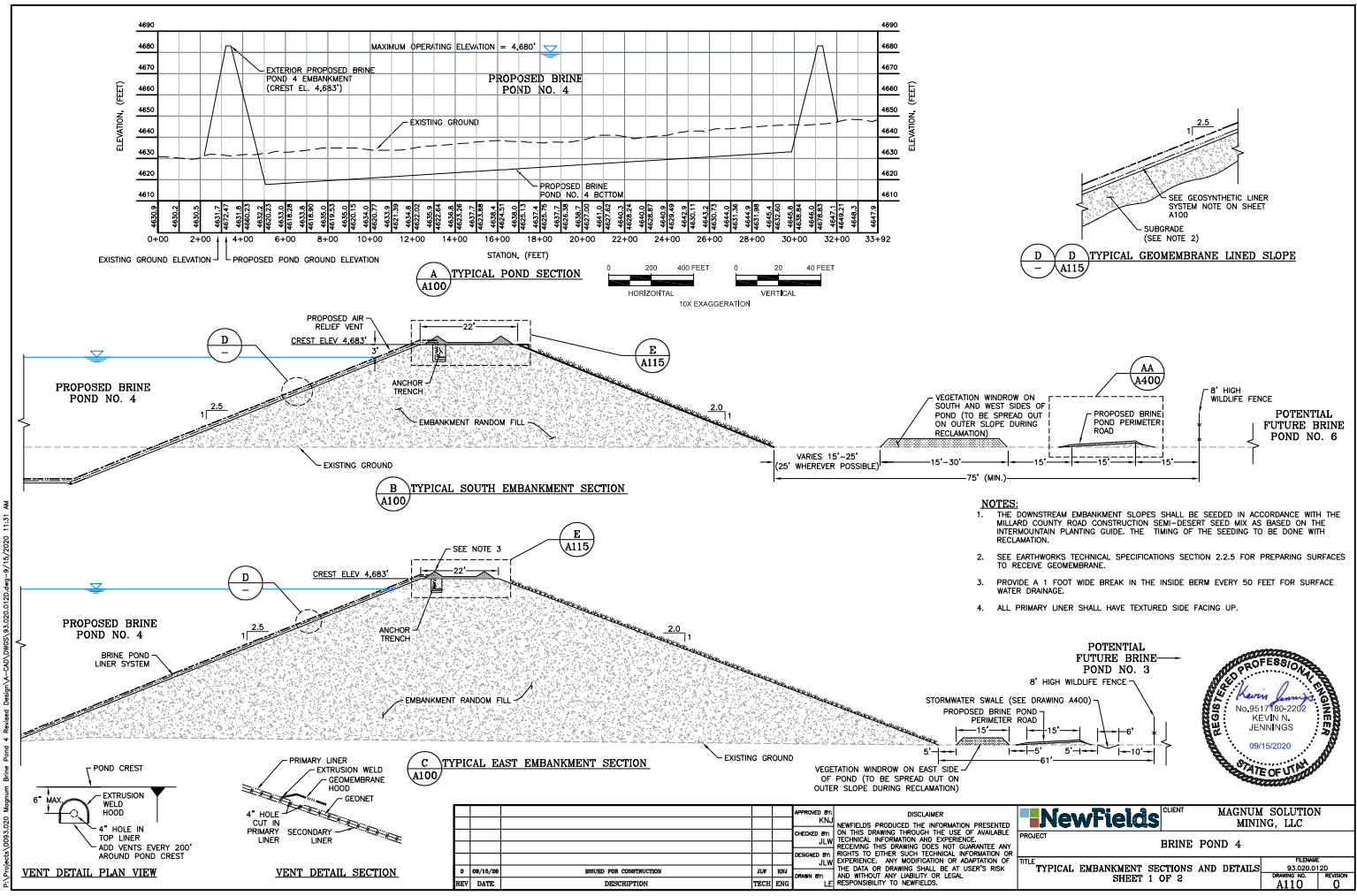

- NOTES:**
1. THE DOWNSTREAM EMBANKMENT SLOPES SHALL BE SEEDED IN ACCORDANCE WITH THE MILLARD COUNTY ROAD CONSTRUCTION SEM-DESERT SEED MIX AS BASED ON THE INTERMOUNTAIN PLANTING GUIDE. THE TIMING OF THE SEEDING TO BE DONE WITH RECLAMATION.
  2. SEE EARTHWORKS TECHNICAL SPECIFICATIONS SECTION 2.2.5 FOR PREPARING SURFACES TO RECEIVE GEOMEMBRANE.
  3. PROVIDE A 1 FOOT WIDE BREAK IN THE INSIDE BERM EVERY 50 FEET FOR SURFACE WATER DRAINAGE.
  4. ALL PRIMARY LINER SHALL HAVE TEXTURED SIDE FACING UP.



REV	DATE	DESCRIPTION	BY	CHK	ENG
1	09/15/20	ISSUED FOR CONSTRUCTION	JW	SK	LE

**APPROVED BY:** KJM  
**CHECKED BY:** JLW  
**DESIGNED BY:** JLW  
**DRAWN BY:** LE

**DISCLAIMER:**  
 NEWFIELDS PRODUCED THE INFORMATION PRESENTED ON THIS DRAWING THROUGH THE USE OF AVAILABLE TECHNICAL INFORMATION AND EXPERIENCE. RECEIVING THIS DRAWING DOES NOT GUARANTEE ANY RIGHTS TO OTHER SUCH TECHNICAL INFORMATION OR EXPERIENCE. ANY MODIFICATION OR ADAPTATION OF THE DATA OR DRAWING SHALL BE AT USER'S RISK AND WITHOUT ANY LIABILITY OR LEGAL RESPONSIBILITY TO NEWFIELDS.

**NewFields** CLIENT: **MAGNUM SOLUTION MINING, LLC**

PROJECT: **BRINE POND 4**

TITLE: **TYPICAL EMBANKMENT SECTIONS AND DETAILS**

SHEET 1 OF 2

PLANNING: 93.020.0120  
 DRAWING NO.: A110  
 REVISION: 0



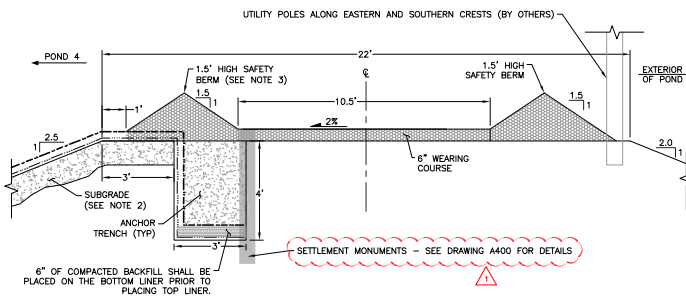

E E TYPICAL POND CREST  
A110 A115

**NOTES:**

1. THE DOWNSTREAM EMBANKMENT SLOPES SHALL BE SEEDED IN ACCORDANCE WITH THE MILLARD COUNTY ROAD CONSTRUCTION SEMI-DESERT SEED MIX AS BASED ON THE INTERMOUNTAIN PLANTING GUIDE. THE TIMING OF THE SEEDING TO BE DONE WITH RECLAMATION.
2. SEE EARTHWORKS TECHNICAL SPECIFICATIONS SECTION 2.2.5 FOR PREPARING SURFACES TO RECEIVE GEOMEMBRANE.
3. PROVIDE A 1 FOOT WIDE BREAK IN THE INSIDE BERM EVERY 50 FEET FOR SURFACE WATER DRAINAGE.
4. ALL PRIMARY LINER SHALL HAVE TEXTURED SIDE FACING UP.



			APPROVED BY: KNJ	DISCLAIMER		CLIENT	MAGNUM SOLUTION MINING, LLC
			CHECKED BY: JLW	NEWFIELDS PRODUCED THE INFORMATION PRESENTED ON THIS DRAWING THROUGH THE USE OF AVAILABLE TECHNICAL INFORMATION AND EXPERIENCE RECEIVING THIS DRAWING DOES NOT GUARANTEE ANY RIGHTS TO OTHER SUCH TECHNICAL INFORMATION OR EXPERIENCE. ANY MODIFICATION OR ADAPTATION OF THE DATA OR DRAWING SHALL BE AT USER'S RISK AND WITHOUT ANY LIABILITY OR LEGAL RESPONSIBILITY TO NEWFIELDS.		PROJECT	BRINE POND 4
1	01/09/21	ISSUED FOR CONSTRUCTION	JLW	DESIGNED BY: JLW	<b>TYPICAL EMBANKMENT SECTIONS AND DETAILS</b> SHEET 2 OF 2	TITLE	TYPICAL EMBANKMENT SECTIONS AND DETAILS
2	04/14/20	ISSUED FOR CONSTRUCTION	JLW	DRAWN BY: LE		PLANSHEET	93.020.0140
REV	DATE	DESCRIPTION	TECH	ENG		DRAWING NO.	A115
						REVISION	1

P:\Projects\0023\_020\_Magnum Brine Pond\_4\_Revise Design\_V-CAD\DWG\03\_03\_2021\_140.dwg 1/28/2021 4:17 PM

P:\Projects\00231.020 - Magnum Brine Pond - Revised Design\A-CAD\DWG\03.020.015P.dwg 9/15/2020 8:52 AM

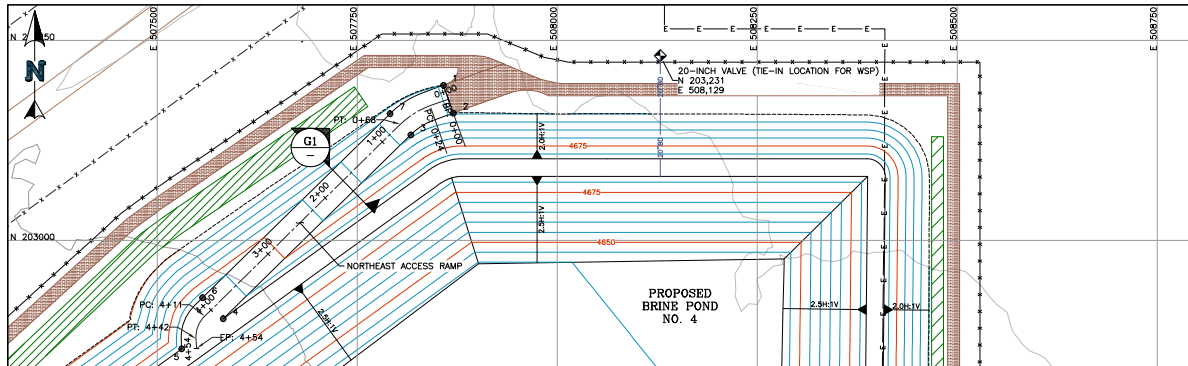

- LEGEND:**
- EXISTING GROUND CONTOURS
  - PROPOSED BRINE POND GROUND CONTOURS
  - PROPOSED WILDLIFE FENCE
  - PROPOSED POWERLINE
  - VEGETATION WINDROW
  - PROPOSED PERIMETER ROAD
  - PROPOSED 20" BRINE DELIVERY LINE
  - SETTING OUT POINTS

SETTING OUT DATA			
POINT	NORTHING	EASTING	ELEVATION
1	203,193.86	507,857.64	4,654.25
2	203,159.01	507,870.06	4,654.25
3	203,131.85	507,816.75	4,658.51
4	202,902.03	507,582.35	4,683.00
5	202,864.39	507,530.34	4,683.00
6	202,928.45	507,556.45	4,683.00
7	203,158.27	507,790.85	4,658.51

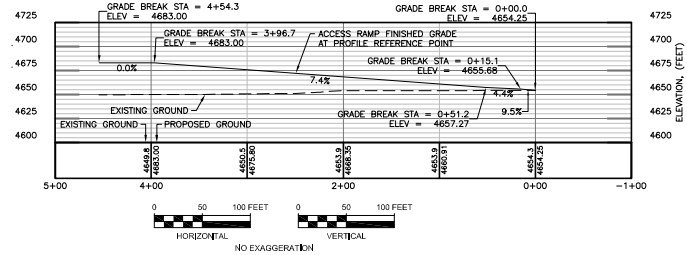

ALIGNMENT TABLE					
STATION	NORTHING	EASTING	DELTA (D-M-S)	LENGTH (FT)	RADIUS (FT)
PT 0+00.00	203,176.43	507,863.85			
PC 0+24.40	203,168.25	507,840.87	024-49-34	44.07	101.71
PT 0+68.47	203,145.06	507,803.80			
PC 4+10.97	202,905.28	507,559.24	048-22-02	31.11	36.85
PT 4+42.07	202,877.16	507,548.23			

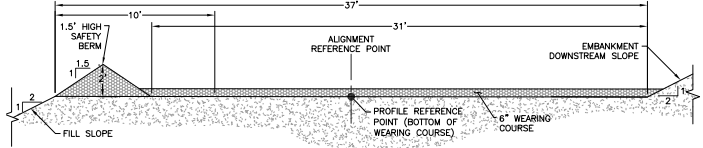

G1 - G1 TYPICAL ACCESS RAMP SECTION  
AI35



APPROVED BY:	KNJ	DISCLAIMER:	NEWFIELDS PRODUCED THE INFORMATION PRESENTED ON THIS DRAWING THROUGH THE USE OF AVAILABLE TECHNICAL INFORMATION AND EXPERIENCE RECEIVING THIS DRAWING DOES NOT GUARANTEE ANY RIGHTS TO OTHER SUCH TECHNICAL INFORMATION OR EXPERIENCE. ANY MODIFICATION OR ADAPTATION OF THE DATA OR DRAWING SHALL BE AT USER'S RISK AND WITHOUT ANY LIABILITY OR LEGAL RESPONSIBILITY TO NEWFIELDS.
CHECKED BY:	JLW	DESIGNED BY:	JLW
DATE:	09/15/20	DRAWN BY:	LE

**NewFields** CLIENT: **MAGNUM SOLUTION MINING, LLC**

PROJECT: **BRINE POND 4**

TITLE: **POND NO. 4 NORTHEAST ACCESS RAMP PLAN AND PROFILE**

DATE: 09/15/2020

REVISION: 0

P:\Projects\0023.020 - Magnum Brine Pond - Revised Design\A-CAD\DWG\3.020.016P.dwg 9/15/2020 11:35 AM

ALIGNMENT TABLE					
STATION	NORTHING	EASTING	DELTA (D-M-S)	LENGTH (FT)	RADIUS (FT)
PT	0+00.00	201,287.23	505,455.60		
PC	6+53.35	200,642.33	505,560.30	044-32-47	54.62
PT	7+07.97	200,596.92	505,598.12		70.26

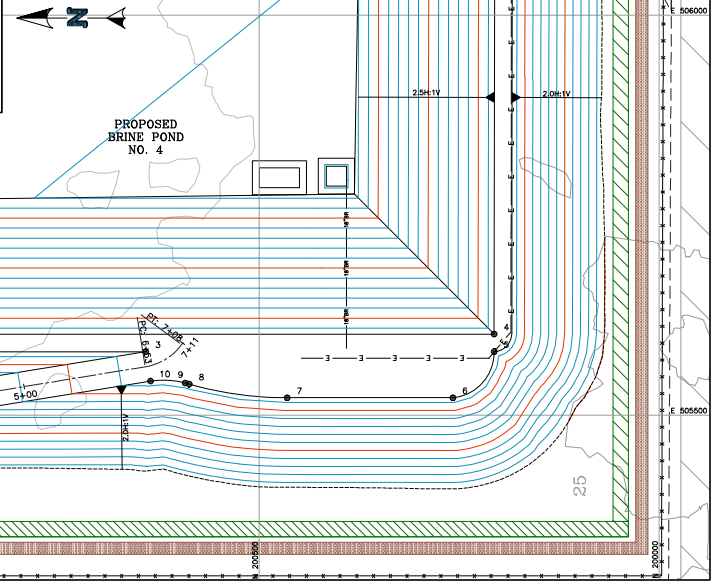

**LEGEND:**

- EXISTING GROUND CONTOURS
- PROPOSED BRINE POND GROUND CONTOURS
- SITE BOUNDARY
- PROPOSED WILDLIFE FENCE
- PROPOSED POWERLINE
- VEGETATION WINDROW
- PROPOSED PERIMETER ROAD
- SETTING OUT POINTS

**SETTING OUT DATA**

POINT	NORTHING	EASTING	ELEVATION
1	201,284.27	505,437.34	4,630.32
2	201,290.20	505,473.86	4,630.32
3	200,641.78	505,579.26	4,683.00
4	200,206.08	505,801.23	4,683.00
5	200,206.13	505,579.31	4,683.00
6	200,257.64	505,521.75	4,683.00
7	200,464.80	505,521.74	4,683.00
8	200,587.25	505,538.73	4,683.00
9	200,592.36	505,540.17	4,683.00
10	200,635.59	505,542.65	4,682.91

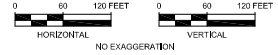
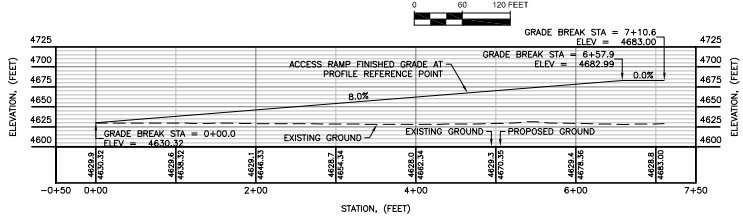

APPROVED BY:	KNJ	DISCLAIMER:	NEWFIELDS PRODUCED THE INFORMATION PRESENTED ON THIS DRAWING THROUGH THE USE OF AVAILABLE TECHNICAL INFORMATION AND EXPERIENCE. RECEIVING THIS DRAWING DOES NOT GUARANTEE ANY RIGHTS TO OTHER SUCH TECHNICAL INFORMATION OR EXPERIENCE. ANY MODIFICATION OR ADAPTATION OF THE DATA OR DRAWING SHALL BE AT USER'S RISK AND WITHOUT ANY LIABILITY OR LEGAL RESPONSIBILITY TO NEWFIELDS.
CHECKED BY:	JLW	DESIGNED BY:	JLW
DATE:	09/15/20	DRAWN BY:	LE

**NewFields** CLIENT: **MAGNUM SOLUTION MINING, LLC**

PROJECT: **BRINE POND 4**

TITLE: **POND NO. 4 SOUTHWEST ACCESS RAMP PLAN AND PROFILE**

DATE: 09/15/2020  
DRAWING NO.: 93.020.016P  
REVISION: A135 0

P:\Projects\00231\_0201 - Magnum Brine Pond 4 - Revised Design\A-CAD\DWG\3.03.20.0180.dwg 9/15/2020 11:35 AM

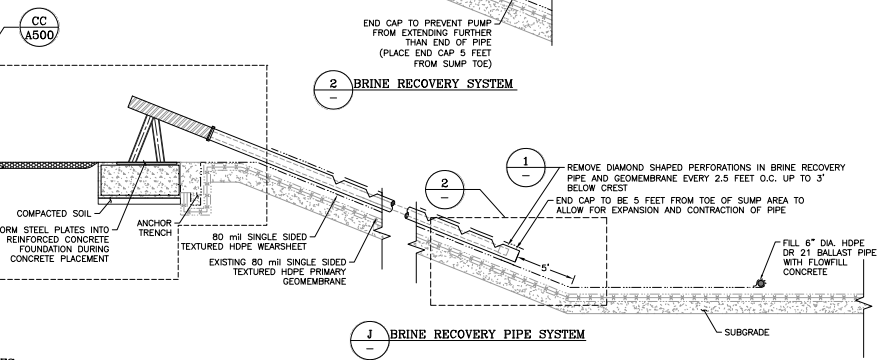
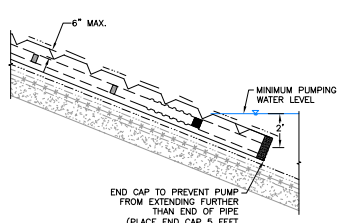
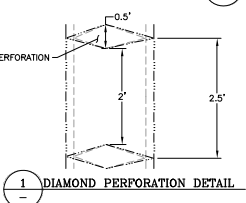
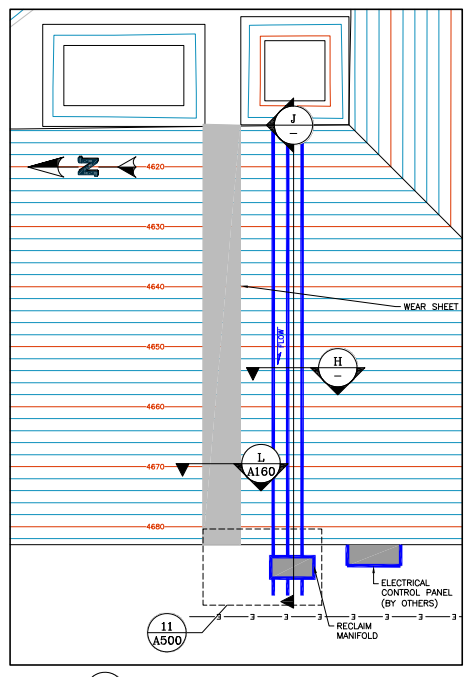
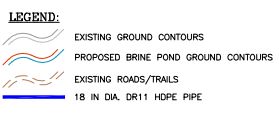
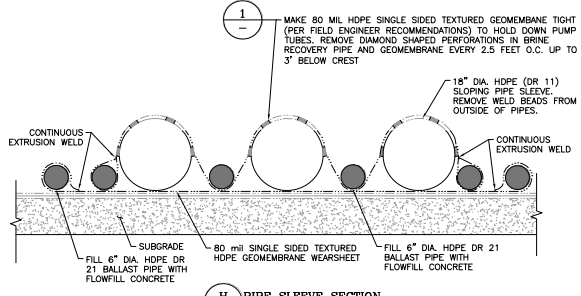

- NOTES:**
- STUB ENDS TO CONSIST OF SCRAP PIECE OF PIPE TO FUNNEL IN CONCRETE. TO BE REMOVED AFTER CONCRETE PLACEMENT.
  - CUT HOLE IN PIPE WALL TO FULL DIAMETER OF STUB END
  - 12-INCH-DIAMETER STUB END TO BE USED FOR POURING CONCRETE PLUG IN PIPE. PIPE FILLED UNTIL CONCRETE COMES OUT OF 6-INCH-DIAMETER PIPE.

REV	DATE	DESCRIPTION	DESIGNED BY	CHECKED BY	APPROVED BY
1	09/15/20	ISSUED FOR CONSTRUCTION	JLW	SKZ	KNJ
2					
3					

**DISCLAIMER**  
 NEWFIELDS PRODUCED THE INFORMATION PRESENTED ON THIS DRAWING THROUGH THE USE OF AVAILABLE TECHNICAL INFORMATION AND EXPERIENCE. RECEIVING THIS DRAWING DOES NOT GUARANTEE ANY RIGHTS TO OTHER SUCH TECHNICAL INFORMATION OR EXPERIENCE. ANY MODIFICATION OR ADAPTATION OF THE DATA OR DRAWING SHALL BE AT USER'S RISK AND WITHOUT ANY LIABILITY OR LEGAL RESPONSIBILITY TO NEWFIELDS.

**NewFields** CLIENT **MAGNUM SOLUTION MINING, LLC**  
 PROJECT **BRINE POND 4**  
 TITLE **BRINE RECOVERY SYSTEM SECTION AND DETAILS**  
 FILENAME **93.020.0180**  
 DRAWING NO. **A140** REVISION **0**



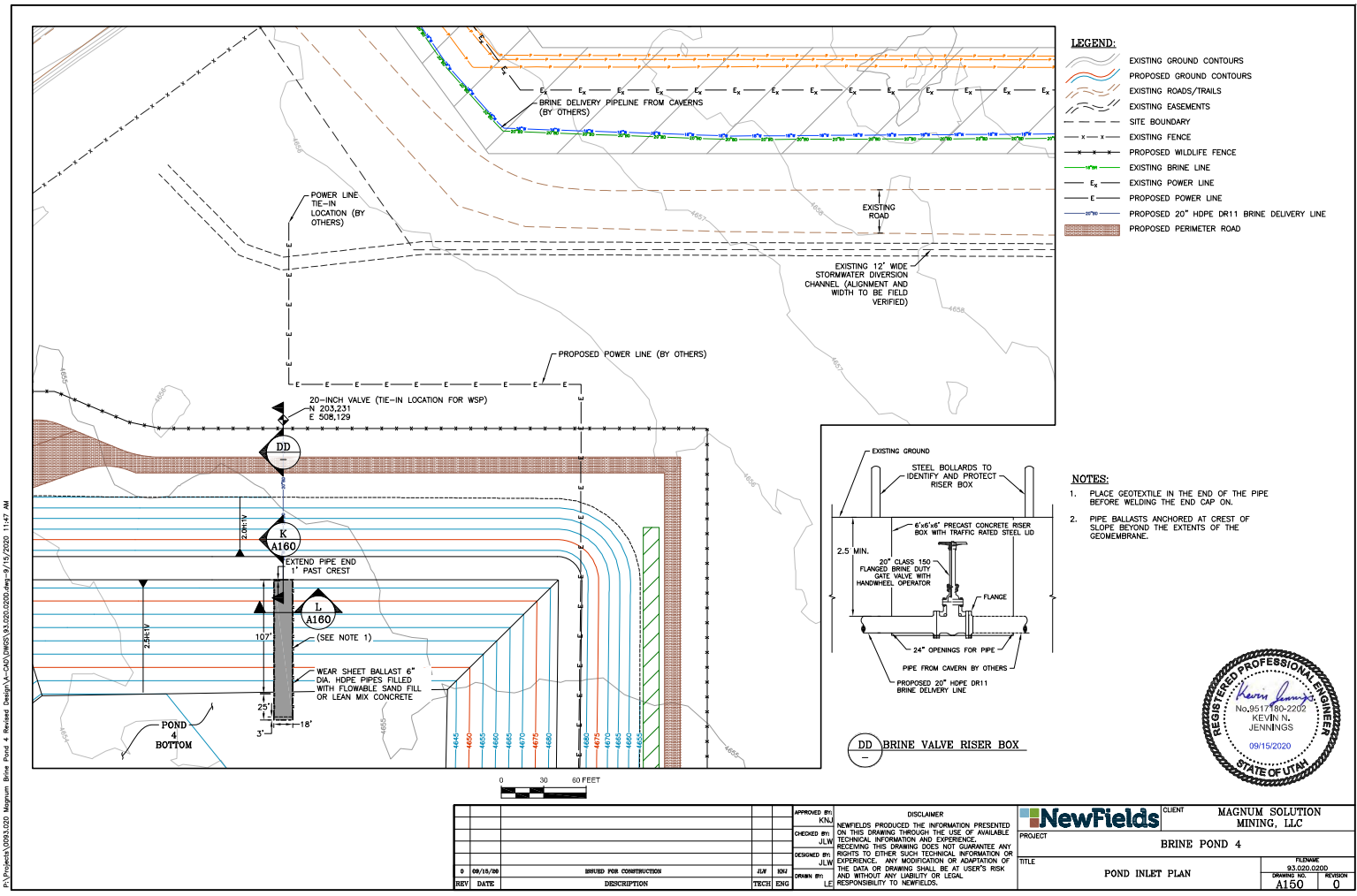

- LEGEND:**
- EXISTING GROUND CONTOURS
  - PROPOSED GROUND CONTOURS
  - EXISTING ROADS/TRAILS
  - EXISTING EASEMENTS
  - SITE BOUNDARY
  - EXISTING FENCE
  - PROPOSED WILDLIFE FENCE
  - EXISTING BRINE LINE
  - EXISTING POWER LINE
  - PROPOSED POWER LINE
  - PROPOSED 20" HOPE DR11 BRINE DELIVERY LINE
  - PROPOSED PERIMETER ROAD

- NOTES:**
1. PLACE GEOTEXTILE IN THE END OF THE PIPE BEFORE WELDING THE END CAP ON.
  2. PIPE BALLASTS ANCHORED AT CREST OF SLOPE BEYOND THE EXTENTS OF THE GEOMEMBRANE.

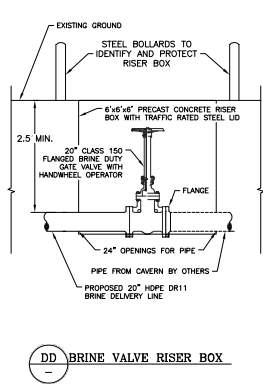

		CLIENT	MAGNUM SOLUTION MINING, LLC
PROJECT		BRINE POND 4	
TITLE		POND INLET PLAN	
APPROVED BY KNJ	DISCLAIMER NEWFIELDS PRODUCED THE INFORMATION PRESENTED ON THIS DRAWING THROUGH THE USE OF AVAILABLE TECHNICAL INFORMATION AND EXPERIENCE RECEIVING THIS DRAWING DOES NOT GUARANTEE ANY RIGHTS TO OTHER SUCH TECHNICAL INFORMATION OR EXPERIENCE. ANY MODIFICATION OR ADAPTATION OF THE DATA OR DRAWING SHALL BE AT USER'S RISK AND WITHOUT ANY LIABILITY OR LEGAL RESPONSIBILITY TO NEWFIELDS.	FILENAME 93.020.0200	REVISION A150 0
CHECKED BY JLW	DESIGNED BY JLW	DRAWN BY LE	DATE 09/15/20
REV	DATE	DESCRIPTION	TECH ENG

P:\Projects\0923.020 - Magnum Brine Pond 4 Revised Design\A-CAD\DWG\93.020.0200.dwg 9/15/2020 11:47 AM

P:\Projects\0923.0201 - Magnum Brine Pond 4 - Revised Design\A-CAD\DWG\03.0201.0220.dwg 9/15/2020 11:47 AM

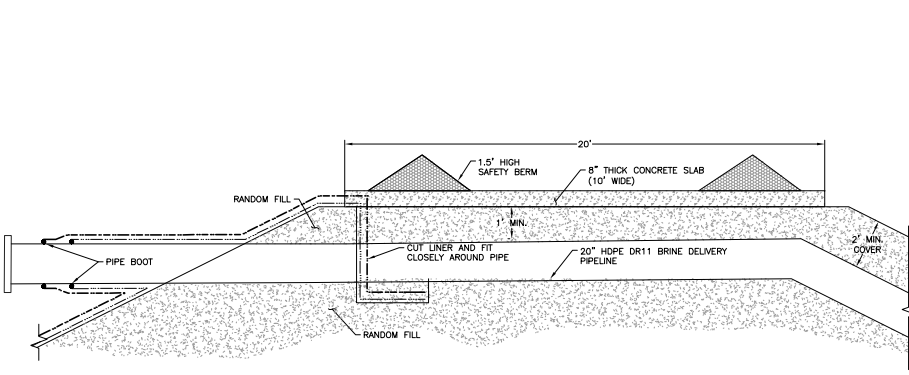

**K PIPE CROSSING CONCRETE CAP**  
A150

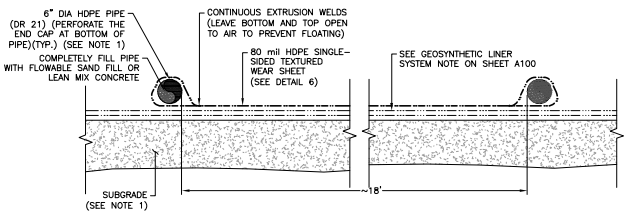

**L POND WEAR SHEET BALLASTING**  
A140 A150

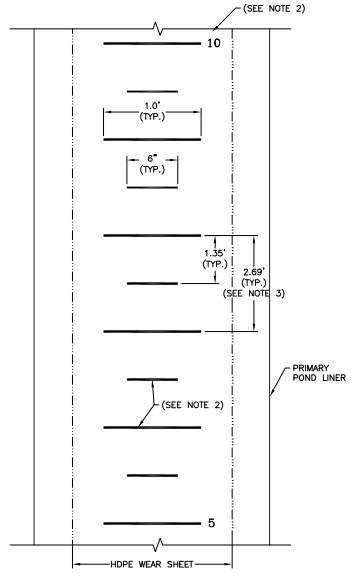

**6 WATER LEVEL GAUGE DETAIL**

- NOTE:**
- PIPE BALLASTS ANCHORED AT CREST OF SLOPE BEYOND THE EXTENTS OF THE GEOMEMBRANE.
  - EXTRUDE INCREMENTS ONTO HDPE WEARSHEET AND APPLY FLUORESCENT COLOR PAINT TO ALL INCREMENTS AND LABEL EVERY 5 FEET.
  - SLOPE DISTANCES SHOWN CORRELATE TO VERTICAL INCREMENTS OF 6" ON A 2.5:1 (HORIZONTAL:VERTICAL) SLOPE (TO BE FIELD VERIFIED BY SURVEY).



		APPROVED BY: KNJ	DISCLAIMER		CLIENT	MAGNUM SOLUTION MINING, LLC
		CHECKED BY: JLW	NEWFIELDS PRODUCED THE INFORMATION PRESENTED ON THIS DRAWING THROUGH THE USE OF AVAILABLE TECHNICAL INFORMATION AND EXPERIENCE. RECEIVING THIS DRAWING DOES NOT GUARANTEE ANY RIGHTS TO OTHER SUCH TECHNICAL INFORMATION OR EXPERIENCE. ANY MODIFICATION OR ADAPTATION OF THE DATA OR DRAWING SHALL BE AT USER'S RISK AND WITHOUT ANY LIABILITY OR LEGAL RESPONSIBILITY TO NEWFIELDS.		PROJECT	BRINE POND 4
		DESIGNED BY: JLW		TITLE	POND INLET SECTIONS AND DETAILS	
REV	DATE	DESCRIPTION	TECH	ENG	FILENAME	93.020.0220
					DRAWING NO.	A160
					REVISION	0

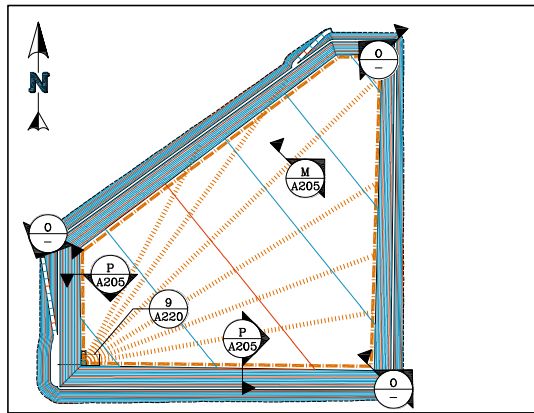

LCRS PIPING AND SUMPS

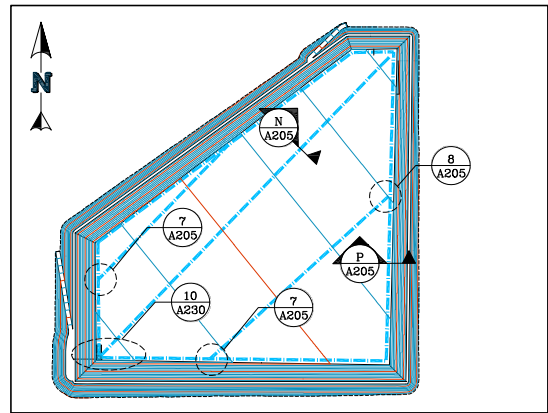

PCMS PIPING AND SUMPS

**LEGEND:**

- PROPOSED BRINE POND GROUND CONTOURS
- 4 IN DIA. PERFORATED HDPE DR17 COLLECTION LCRS PIPE
- LCRS 18" WIDE STRIP DRAIN
- 4 IN DIA. PERFORATED CPe COLLECTION PCMS PIPE

**NOTE:**

1. SEE EARTHWORKS MATERIALS AND CONSTRUCTION TECHNICAL SPECIFICATIONS SECTION 2.2.5 FOR PREPARING SURFACES TO RECEIVE GEOMEMBRANE.
2. THE MONITORING SLEEVE SHALL BE PERFORATED IN THE SAME MANNER AS THE LCRS PIPES LOCATED ALONG THE INSIDE EMBANKMENT TOE. THE SLEEVES SHALL BE LOCATED AT THE EASTERN, NORTHEASTERN AND NORTHERN CORNERS OF THE POND.

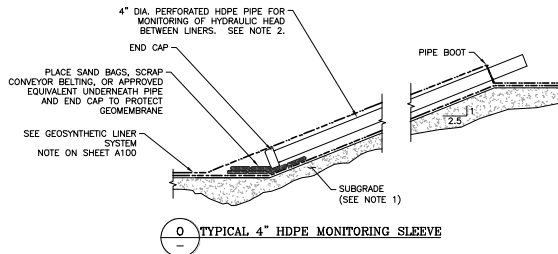

○ TYPICAL 4" HDPE MONITORING SLEEVE

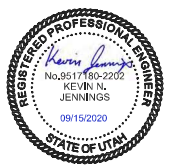

APPROVED BY: KNJ		DISCLAIMER		NewFields		CLIENT: MAGNUM SOLUTION MINING, LLC	
CHECKED BY: JLW		NEWFIELDS PRODUCED THE INFORMATION PRESENTED ON THIS DRAWING THROUGH THE USE OF AVAILABLE TECHNICAL INFORMATION AND EXPERIENCE RECEIVING THIS DRAWING DOES NOT GUARANTEE ANY RIGHTS TO OTHER SUCH TECHNICAL INFORMATION OR EXPERIENCE. ANY MODIFICATION OR ADAPTATION OF THE DATA OR DRAWING SHALL BE AT USER'S RISK AND WITHOUT ANY LIABILITY OR LEGAL RESPONSIBILITY TO NEWFIELDS.		PROJECT: BRINE POND 4		TITLE: POND BASIN PIPING PLAN	
REV	DATE	DESCRIPTION	TECH	ENG	LE	DATE: 09/15/2020	REVISION: 0

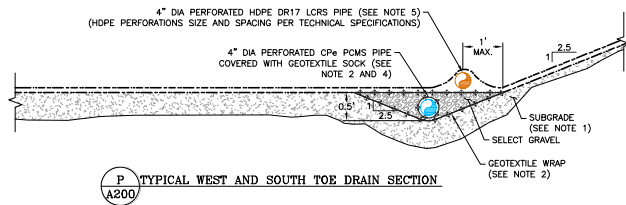
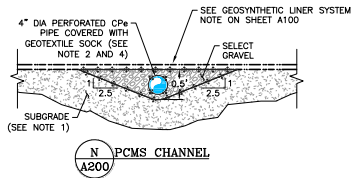
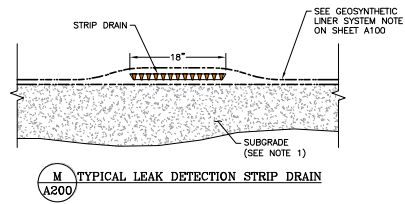
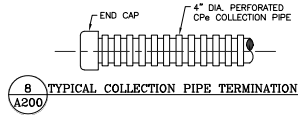
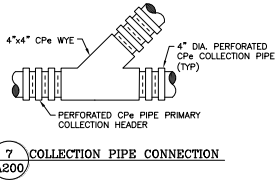

**NOTES:**

1. SEE EARTHWORKS MATERIALS AND CONSTRUCTION TECHNICAL SPECIFICATIONS SECTION 2.2.5 FOR PREPARING SURFACES TO RECEIVE GEOMEMBRANE.
2. GEOTEXTILE SOCK SHALL BE NON-WOVEN 10 oz/yd<sup>2</sup>.
3. ALL PRIMARY LINER SHALL HAVE TEXTURED SIDE FACING UP.
4. PIPE PERFORATIONS SHALL BE IN ACCORDANCE WITH CLASS II AASHTO M252 SPECIFICATION OR APPROVED EQUIVALENT. (SLOT LENGTH = 0.675 IN., WIDTH = 0.125 IN.)
5. ENSURE THE END OF THE PIPE EITHER HAS REDUCERS, OR OTHER MEANS APPROVED BY THE ENGINEER, TO PROTECT THE LINER FROM SHARP EDGES.

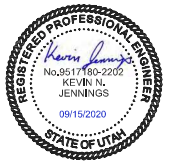

APPROVED BY: KNJ		DISCLAIMER		NewFields CLIENT	
CHECKED BY: JLW		NEWFIELDS PRODUCED THE INFORMATION PRESENTED ON THIS DRAWING THROUGH THE USE OF AVAILABLE TECHNICAL INFORMATION AND EXPERIENCE RECEIVING THIS DRAWING DOES NOT GUARANTEE ANY RIGHTS TO OTHER SUCH TECHNICAL INFORMATION OR EXPERIENCE. ANY MODIFICATION OR ADAPTATION OF THE DATA OR DRAWING SHALL BE AT USER'S RISK AND WITHOUT ANY LIABILITY OR LEGAL RESPONSIBILITY TO NEWFIELDS.		MAGNUM SOLUTION MINING, LLC	
DESIGNED BY: JLW		PROJECT		BRINE POND 4	
DRAWN BY: LE		TITLE		POND BASIN PIPING SECTIONS AND DETAILS	
REV	DATE	DESCRIPTION	TECH	ENG	TALKING: 93.020.0260 DRAWING NO: A205 REVISION: 0





P:\Projects\0203\0203\_0203\_0203\_0203.dwg 9/15/2020 3:15 PM  
 Magnum Brine Pond 4 Revised Design\A-CAD\DWG\0203\0203\_0203\_0203.dwg 9/15/2020 3:15 PM

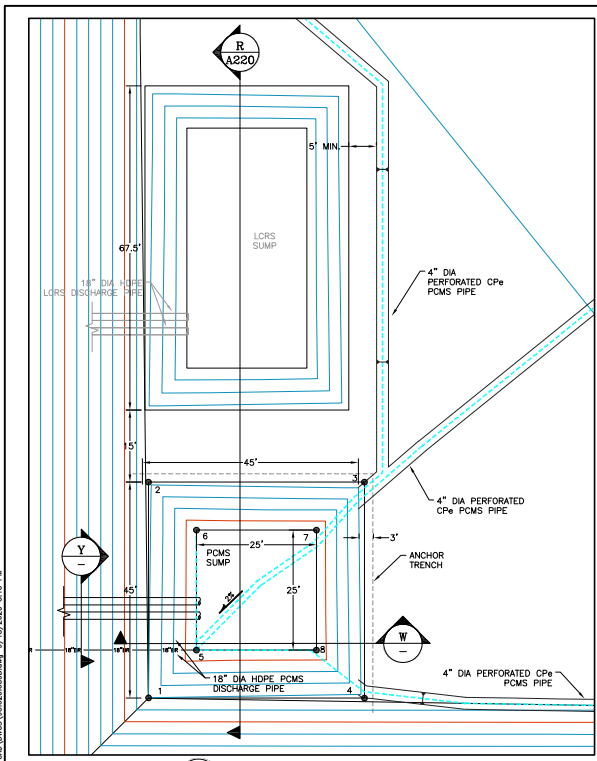

10 PCMS PIPING AND SUMP  
A200

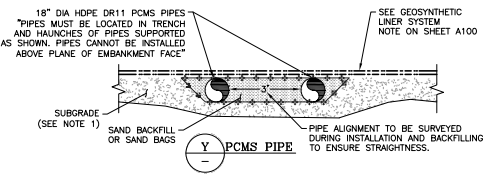

Y PCMS PIPE

POND 4 SETTING OUT DATA			
POINT	NORTHING	EASTING	ELEVATION
1	200,380.89	505,776.23	4,613.00
2	200,425.84	505,776.18	4,613.25
3	200,425.84	505,821.18	4,613.53
4	200,380.84	505,821.18	4,613.30
5	200,390.84	505,786.18	4,609.10
6	200,415.64	505,786.18	4,609.14
7	200,415.84	505,811.18	4,609.18
8	200,390.84	505,811.18	4,609.14

- NOTES:**
- SEE EARTHWORKS MATERIALS AND CONSTRUCTION TECHNICAL SPECIFICATIONS SECTION 2.2.5 FOR PREPARING SURFACES TO RECEIVE GEOMEMBRANE.
  - GEOTEXTILE SOCK SHALL BE NON-WOVEN 10 oz./y<sup>2</sup>.
  - ALL PRIMARY LINER SHALL HAVE TEXTURED SIDE FACING UP.
  - PIPE PERFORATIONS SHALL BE IN ACCORDANCE WITH CLASS II AASHTO M252 SPECIFICATION OR APPROVED EQUIVALENT. (SLOT LENGTH = 0.875 IN., WIDTH = 0.125 IN.)

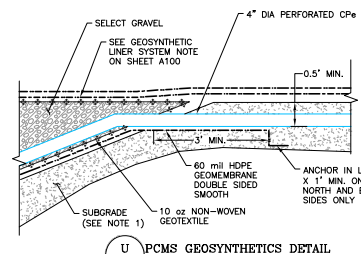

U PCMS GEOSYNTHETICS DETAIL

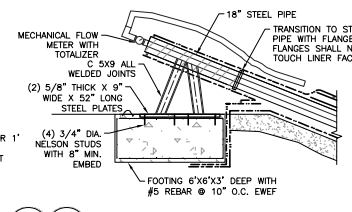

V PCMS AND LCRS SUPPORT AND ANCHOR DETAIL

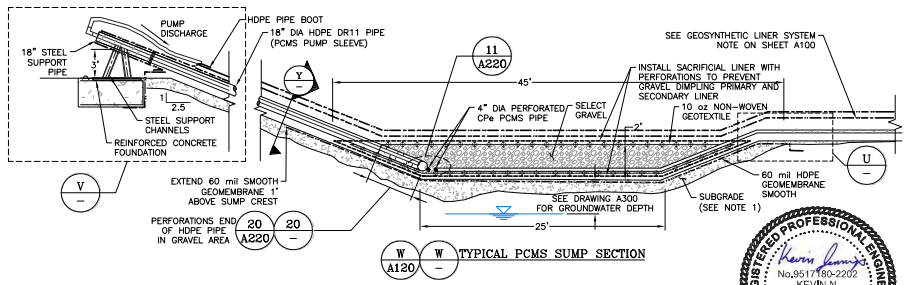

W TYPICAL PCMS SUMP SECTION

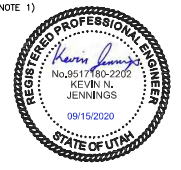

REV	DATE	DESCRIPTION	BY	CHK	ENG	LE

	CLIENT	MAGNUM SOLUTION MINING, LLC
	PROJECT	BRINE POND 4
TITLE	PROCESS COLLECTION AND MONITORING SYSTEM PLAN	TALKING 93.020.0300 DRAWING NO. A230 REVISION 0

APPROVED BY: KNL  
 CHECKED BY: JLW  
 DESIGNED BY: JLW  
 DRAWN BY: LE

DISCLAIMER:  
 NEWFIELDS PRODUCED THE INFORMATION PRESENTED ON THIS DRAWING THROUGH THE USE OF AVAILABLE TECHNICAL INFORMATION AND EXPERIENCE. RECEIVING THIS DRAWING DOES NOT GUARANTEE ANY RIGHTS TO OTHER SUCH TECHNICAL INFORMATION OR EXPERIENCE. ANY MODIFICATION OR ADAPTATION OF THE DATA OR DRAWING SHALL BE AT USER'S RISK AND WITHOUT ANY LIABILITY OR LEGAL RESPONSIBILITY TO NEWFIELDS.

P:\Projects\0023\_020\_Magnum Brine Pond 4 Revised Design\A-CAD\DWG\03.02.020.dwg - 1/28/2021 4:17 PM

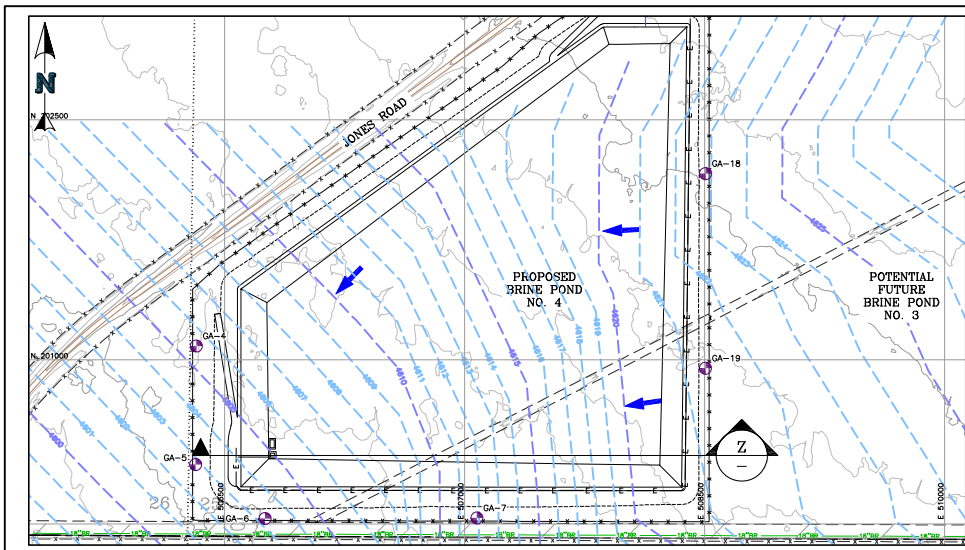

- LEGEND:**
- EXISTING GROUND CONTOURS
  - APPROXIMATE GROUNDWATER CONTOURS BASED ON JUNE, 2017 SITE INVESTIGATION, MARCH 2015 SITE INVESTIGATION, IGES 2011 SITE INVESTIGATION, AND NEWFIELDS 2020 SITE INVESTIGATION
  - EXISTING ROADS/TRAILS
  - GA-01 EXISTING GROUND WATER MONITORING WELLS TO REMAIN
  - GA-12 PROPOSED GROUND WATER MONITORING WELLS
  - APPROXIMATE GROUNDWATER FLOW DIRECTION

- NOTES:**
1. MONITORING WELLS WILL BE CONSTRUCTED IN COMPLIANCE WITH UTAH ADMINISTRATIVE RULE R655-4-15.
  2. ESTIMATED DEPTH TO WATER IS APPROXIMATELY 15 TO 20 FEET BELOW EXISTING GROUND SURFACE.
  3. HOLLOW STEM AUGER DRILLING METHOD IS PREFERRED; ALTHOUGH, OTHERS COULD BE CONSIDERED BASED ON RIG AVAILABILITY.
  4. SCREEN LENGTH WILL BE SPECIFIED IN THE FIELD BASED ON SUBSURFACE CONDITIONS, BUT ANTICIPATED LENGTH IS 10 - 20 FEET.
  5. FILTER PACK AND WELL SEALANTS WILL BE TREMIED IN PLACE FROM THE BOTTOM UP.
  6. WELL DEVELOPMENT WILL BE COMPLETED THROUGH USE OF A BAILER OR PUMP.

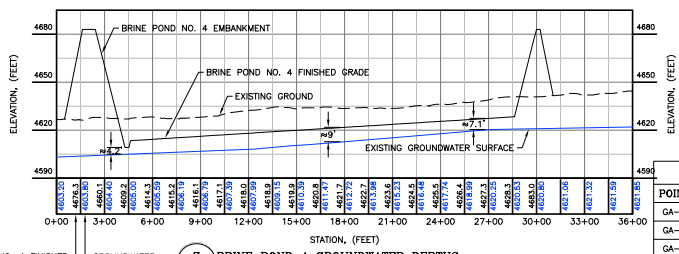
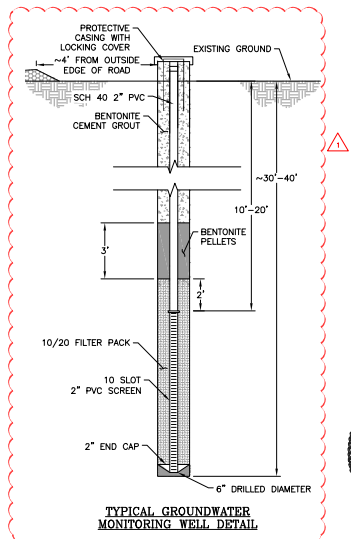

**SETTING OUT DATA**

POINT	NORTHING	EASTING	ELEVATION
GA-4	201,086.18	505,322.74	4,630.00
GA-5	200,345.23	505,318.08	4,626.59
GA-6	200,007.73	505,751.69	4,625.59
GA-7	200,011.24	507,075.74	4,632.98
GA-18	202,163.53	508,504.91	4,650.93
GA-19	200,946.77	508,504.91	4,644.00

REV	DATE	DESCRIPTION	BY	CHK	ENG
1	01/29/21	ISSUED FOR CONSTRUCTION	JLW	SKL	
2	04/16/20	ISSUED FOR CONSTRUCTION	JLW	SKL	

**APPROVED BY:** KNL  
**DISCLAIMER:** NEWFIELDS PRODUCED THE INFORMATION PRESENTED ON THIS DRAWING THROUGH THE USE OF AVAILABLE TECHNICAL INFORMATION AND EXPERIENCE. RECEIVING THIS DRAWING DOES NOT GUARANTEE ANY RIGHTS TO OTHER SUCH TECHNICAL INFORMATION OR THE DATA OR DRAWING SHALL BE AT USER'S RISK AND WITHOUT ANY LIABILITY OR LEGAL RESPONSIBILITY TO NEWFIELDS.

**CLIENT:** MAGNUM SOLUTION MINING, LLC  
**PROJECT:** BRINE POND 4  
**TITLE:** POND SITE GROUNDWATER DEPTHS PLAN AND PROFILE  
**DATE:** 03/20/2020  
**REVISION:** A300 1

P:\Projects\002312021 - Magnum Brine Road - Revised Design\A-CAD\DWG\03.020.0340.dwg 9/15/2020 3:33 PM

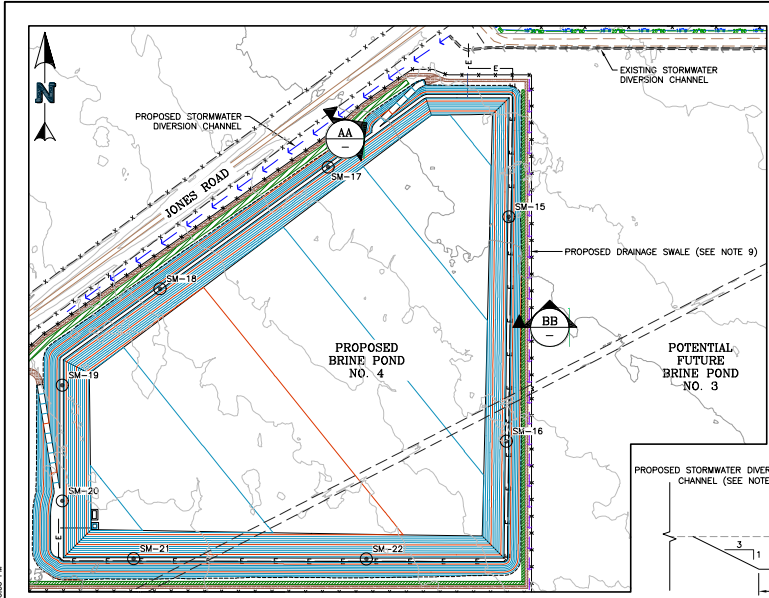

- LEGEND:**
- EXISTING GROUND CONTOURS
  - PROPOSED BRINE POND GROUND CONTOURS
  - EXISTING ROADS/TRAILS
  - EXISTING STORMWATER DIVERSION CHANNEL
  - PROPOSED STORMWATER DIVERSION CHANNEL
  - PROPOSED DRAINAGE SWALE
  - PROPOSED EMBANKMENT SETTLEMENT MONUMENTS (SEE NOTE 6)

- NOTES:**
1. FINAL LOCATION OF ROAD AND DIVERSION CHANNEL TO BE DETERMINED DURING CONSTRUCTION BY THE FIELD ENGINEER.
  2. DIVERSION CHANNELS SHALL BE CONSTRUCTED AT A MINIMUM 0.3% SLOPE TO MINIMIZE EARTHWORKS.
  3. DIVERSION CHANNELS SHALL BE CONSTRUCTED WITH A MINIMUM 2 FOOT DEPTH.
  4. BRINE POND PERIMETER ROAD SHALL BE CONSTRUCTED WITH A MINIMUM 6" THICK WEARING COURSE.
  5. CULVERTS AND LOCAL DITCHES SHALL BE CONSTRUCTED AS REQUIRED TO MINIMIZE PONDING OF SURFACE WATER, LOCATIONS TO BE DETERMINED IN THE FIELD.
  6. FINAL LOCATION OF SETTLEMENT MONUMENTS TO BE DETERMINED DURING CONSTRUCTION BY THE OWNER OR OWNER'S REPRESENTATIVE.
  7. FIELD VERIFY AND EXTEND CHANNEL IF NECESSARY TO ALLOW PROPER DRAINAGE SLOPE.
  8. THE DIVERSION CHANNEL SHALL BE GRADED AS SUCH TO OUTFALL INTO NATURAL DRAINAGE WAYS WHEN POSSIBLE.
  9. A DRAINAGE SWALE SHOULD BE CONSTRUCTED ADJACENT TO THE EAST PERIMETER ROAD TO DIRECT STORM RUNOFF PAST THE SOUTHEAST CORNER OF THE POND.
  10. THIS CHANNEL SECTION SHOULD CONTINUE SOUTHWEST UNTIL IT CAN DISCHARGE INTO THE EXISTING CHANNEL ALONG THE SOUTHEAST SIDE OF JONES ROAD.

POINT	NORTHING	EASTING	ELEVATION
SM-15	202,336.65	508,385.78	4,683.00
SM-16	200,933.82	508,370.22	4,683.00
SM-17	202,646.69	507,256.73	4,683.00
SM-18	201,886.70	506,206.33	4,683.00
SM-19	201,283.62	505,595.23	4,683.00
SM-20	200,560.93	505,595.23	4,683.00
SM-21	200,199.60	506,041.64	4,683.00
SM-22	200,198.01	507,496.17	4,683.00

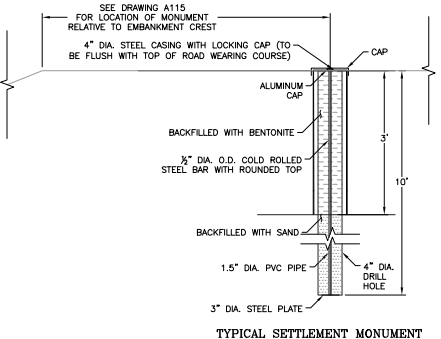
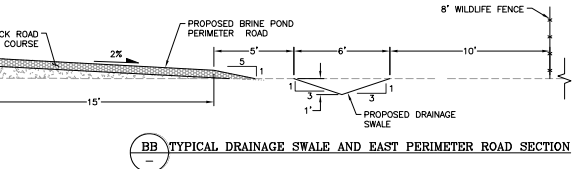
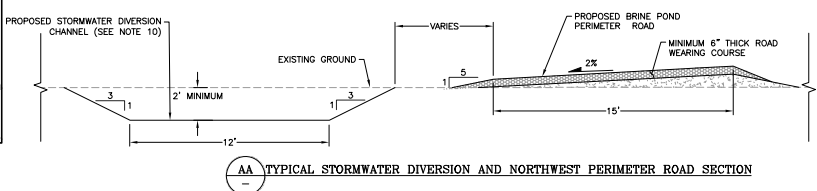

APPROVED BY:	KNJ	DISCLAIMER:	NEWFIELDS PRODUCED THE INFORMATION PRESENTED ON THIS DRAWING THROUGH THE USE OF AVAILABLE TECHNICAL INFORMATION AND EXPERIENCE RECEIVING THIS DRAWING DOES NOT GUARANTEE ANY RIGHTS TO OTHER SUCH TECHNICAL INFORMATION OR EXPERIENCE. ANY MODIFICATION OR ADAPTATION OF THE DATA OR DRAWING SHALL BE AT USER'S RISK AND WITHOUT ANY LIABILITY OR LEGAL RESPONSIBILITY TO NEWFIELDS.
CHECKED BY:	JLW	DESIGNED BY:	JLW
DATE:	09/15/20	DRAWN BY:	LE

**NewFields** CLIENT: **MAGNUM SOLUTION MINING, L.L.C.**

PROJECT: **BRINE POND 4**

TITLE: **STORMWATER DIVERSION AND SETTLEMENT MONUMENT PLAN**

DATE: 09/15/20

REVISION: 0

P:\Projects\0923\_0203\_Magnum Brine Pond 4 Revised Design\A-CAD\DWG\03.0203.0203.R01.dwg 9/15/2020 2:18 PM

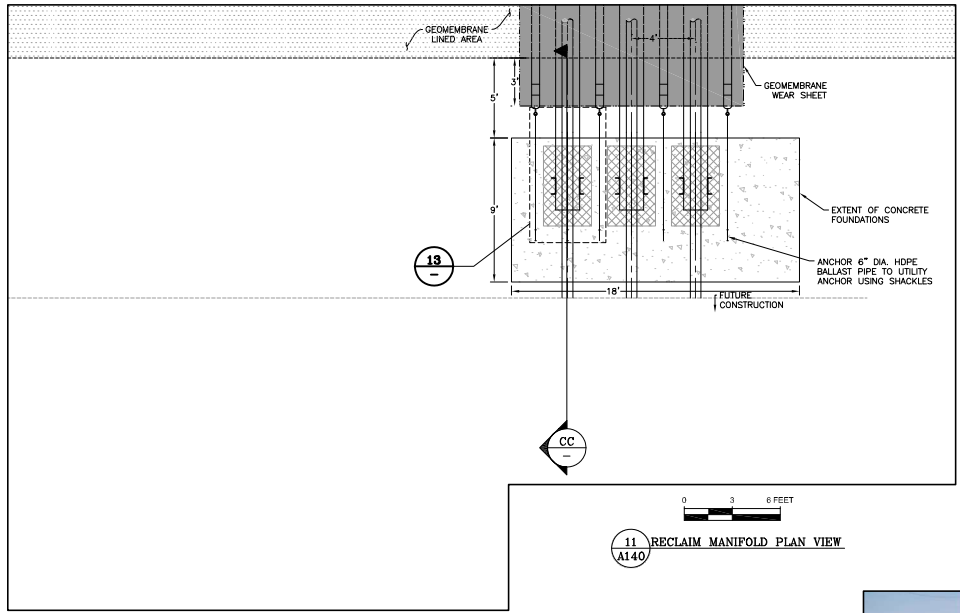

11 RECLAIM MANIFOLD PLAN VIEW  
A140

**NOTES:**

1. COMPACT SOIL TO 95% STANDARD PROCTOR DENSITY UNDER THE CONCRETE FOUNDATION FOOTPRINT.
2. COAT STEEL AND CONCRETE WITH TNEPEC EPOXILINE SERIES 141 OR SIMILAR FOR CORROSION PROTECTION.
3. POSITION STEEL PLATE OR PLATES SO THAT CHANNEL LEGS CAN BE WELDED AT PLATE AND SLOPING PIPE SLEEVE.
4. FUTURE PIPING TO BE DETAIL DESIGNED IN FUTURE.

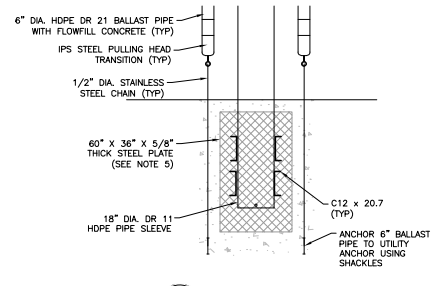

13 STEEL PLATE PLAN VIEW

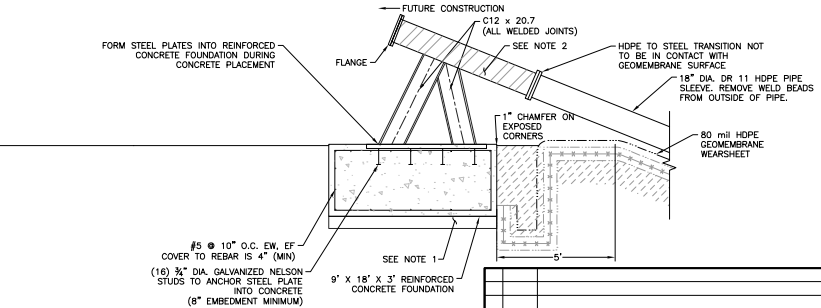

19 BRINE RECOVERY MANIFOLD SECTION  
A140



EXISTING BRINE RECOVERY ANCHOR SYSTEM FROM SAWTOOTH BRINE POND 1 FOR FABRICATION REFERENCE



REV	DATE	DESCRIPTION	DESIGNED BY	CHKD BY	ENGR BY
1	09/15/20	ISSUED FOR CONSTRUCTION	JLW	SKJ	LE

APPROVED BY: KNL  
 CHECKED BY: JLW  
 DESIGNED BY: JLW  
 DRAWN BY: LE

**DISCLAIMER**  
 NEWFIELDS PRODUCED THE INFORMATION PRESENTED ON THIS DRAWING THROUGH THE USE OF AVAILABLE TECHNICAL INFORMATION AND EXPERIENCE. RECEIVING THIS DRAWING DOES NOT GUARANTEE ANY RIGHTS TO OTHER SUCH TECHNICAL INFORMATION OR EXPERIENCE. ANY MODIFICATION OR ADAPTATION OF THE DATA OR DRAWING SHALL BE AT USER'S RISK AND WITHOUT ANY LIABILITY OR LEGAL RESPONSIBILITY TO NEWFIELDS.

<b>NewFields</b>	CLIENT	MAGNUM SOLUTION MINING, LLC
PROJECT		
BRINE POND 4		
TITLE	BRINE RECOVERY MANIFOLD SECTIONS AND DETAILS	PLANSHEET
		93.020.0360
		DRAWING NO. A500
		REVISION 0

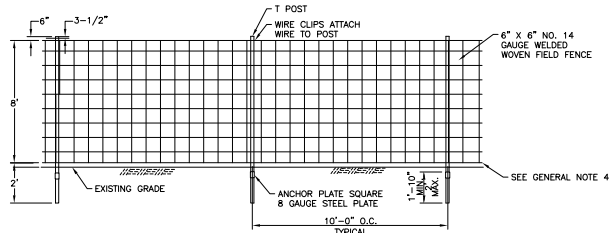

LINE PANELS

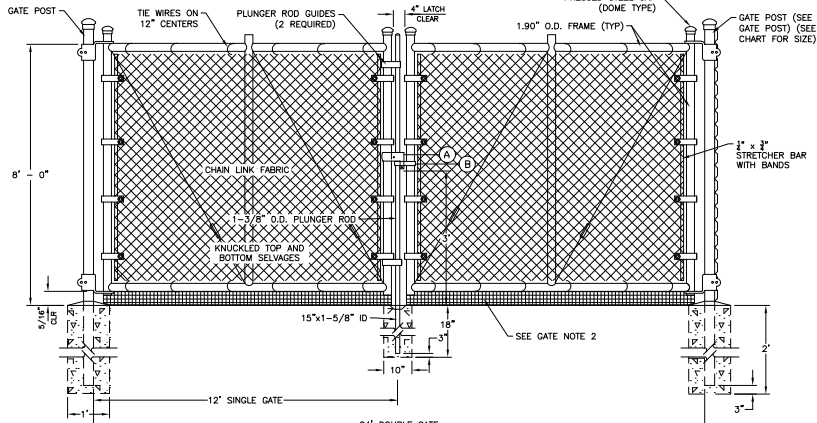

SWING GATE

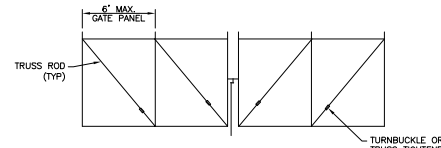

FRAME CONSTRUCTION GATES OVER 12'-0" TO 24'-0" OPENING

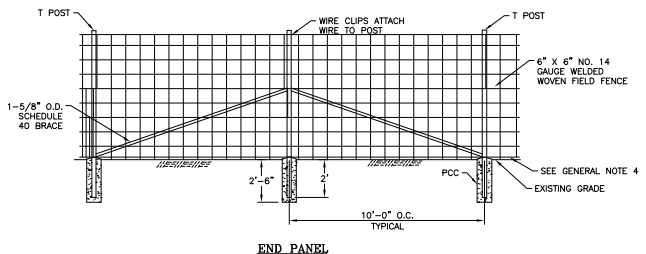
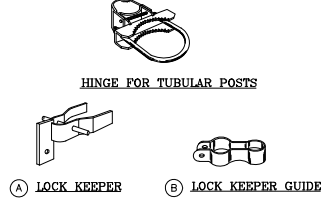

END PANEL

- PANEL NOTES:**
1. END PANELS SHALL BE PLACED EVERY 1000' ON TANGENTS.
  2. END PANELS SHALL BE USED WHEREVER A BREAK IN THE FENCE OCCURS, (I.E. GATES, CATTLE GUARDS) AND AT THE BEGINNING AND END OF ALL CURVES.
  3. WIRES ARE TO BE TIED OFF AT STRETCH POINTS, WRAP AND SPLICE TO SELF WITH AT LEAST 4 TURNS AT OPPOSITE END OF PANELS.
  4. FENCE SHALL BE INSTALLED TIGHT TO THE GROUND.

- GATE NOTES:**
1. 1" ADJUSTABLE TRUSS RODS SHALL BE INSTALLED ON ALL GATES OVER 6 FEET IN WIDTH (SEE DETAIL B, SHEET C3.09, FOR TRUSS TIGHTENER DETAIL).
  2. 2" x 2" NO. 12-1/2 GAUGE WIRE MESH OR 11-1/2 GAUGE CHAIN LINK FABRIC TO BE INSTALLED AT THE BOTTOM OF GATES AS REQUIRED TO CLOSE GAP BETWEEN GATE FRAME AND GROUND.

- GENERAL NOTES:**
1. DIAMETERS AND WEIGHTS LISTED ABOVE ARE MINIMUMS. LARGER SIZES MAY BE USED ON APPROVAL OF ENGINEER.
  2. 3-1/2" x 3-1/2" TYPE II POST (4.65 LBS/FT) CAN BE USED IN PLACE OF 2.875" O.D. ROUND GATE POST.
  3. CONCRETE SHALL BE CLASS A OR AA.
  4. FENCE FABRIC IS TO BE PLACED FLUSH WITH THE EXISTING GROUND.

**WILDLIFE FENCE**  
NTS

GATE POST		ROUND GATE POLES (O.D. (INCHES))	MIN. WEIGHT POUNDS/LIN. FEET	
GATE OPENING IN FEET	DOUBLE GATE		CLASS 1	CLASS 2
SINGLE GATE	DOUBLE GATE	4.000	9.11	6.56
7 THRU 13	13 THRU 26			



APPROVED BY:	KNJ	DISCLAIMER:	NEWFIELDS PRODUCED THE INFORMATION PRESENTED ON THIS DRAWING THROUGH THE USE OF AVAILABLE TECHNICAL INFORMATION AND EXPERIENCE RECEIVING THIS DRAWING DOES NOT GUARANTEE ANY RIGHTS TO OTHER SUCH TECHNICAL INFORMATION OR EXPERIENCE. ANY MODIFICATION OR ADAPTATION OF THE DATA OR DRAWING SHALL BE AT USER'S RISK AND WITHOUT ANY LIABILITY OR LEGAL RESPONSIBILITY TO NEWFIELDS.
CHECKED BY:	JLW	DESIGNED BY:	JLW
DATE:	09/15/20	DRAWN BY:	LE

**NewFields** CLIENT: **MAGNUM SOLUTION MINING, LLC**

PROJECT: **BRINE POND 4**

TITLE: **WILDLIFE FENCE DETAILS**

DATE: 09/15/20

REVISION: 0

DWQ-2021-004917

**Signature:**   
**Email:** egaddis@utah.gov

**Signature:**   
Woodrow Campbell (R) 2021-2023  
**Email:** wwcampbell@utah.gov